

Installation guide

1. Description

The **Loop Warden Handset** (Item no **ASS63LWIPS**) connects to the 6350-LILC Card which is fitted within the EICIE panel.

The cabling to the Warden Handsets originates from the LILC and loops through each Warden Handset and returns to the LILC to create a redundant loop circuit (see page 4). Cable connections between the LILC and each Loop Warden Handset are polarity sensitive.

Each LILC supports **2 loop circuits**, and each loop can connect up to 20 Loop Warden Handsets. A maximum of 40 Warden Handsets can therefore connect to each LILC.

The EICIE system can be expanded further by adding more LILCs and GUI Control Cards which provide the total number of zone controls required.

Each Loop Warden Handset is configured as an address number (between 1-20) via the **dipswitch setting** inside the Warden Handset on the PCB.

Each Loop Warden Handset address needs to be assigned to an **EIS Zone** number between **1 to 1024** within the configuration file. Descriptors can be added to detail their location.

Each zone is provided control buttons 'Call & Clear' and assigned into the EIS keypad layout in the system configuration file

Each Loop Warden Handset can interconnect with an EAID via the dedicated system input (White Emergency MCP) input terminals marked +- **EAID**.

If the Warden Handset ring tone is deemed insufficient an external WIP Remote Buzzer Plate (Item No 209-0028) can be connected onto the terminals marked +- **BUZZ**. This is typically used when the Warden Handset is located inside an enclosure, panel or behind a door.

The loop circuits require (2 core UTP) Unshielded Twisted Pair field cabling wired in a loop configuration connecting a maximum of 20 Loop Warden Handsets over a maximum loop length of 1km. The distance between any two Warden Handsets shall not exceed 500m.

The cable size recommended is 1.5mm² Unshielded twisted pair.

Each Warden Handset should be fixed in an upright vertical position when fixed on a wall, so the handset sits firmly on the cradle

Suggested Fixing Height: between 1.1m – 1.3m from floor level

Suggested Fixing Screw Size: Metal Roundhead 8g x 30mm

Fixing Centers on the Warden Handset are 188mm apart vertically.

Two LED indicators are located on the PCB inside the Warden Handset between the Buzzer and EAID terminals.

The LEDs cannot be seen once the Warden Handset cover is fixed on. The two LEDs provide the person commissioning visual indications which help outline the condition of the Warden Handset.

In normal operation when wired as a loop circuit the LED status should be as follows:

- Both LEDs will illuminate ON steady. The steady LED indicates the port **input voltage 48 V DC and communications protocol** from the LILC is received.
- If comms from the LILC becomes lost the steady LED changes state and begins **to flash**.
- The incoming primary line voltage to each Warden Handset is typically **48 V DC** under normal circumstances (via the loop circuit) for the Warden Handsets to operate within specification.

In the event of short circuit, the LED on the affected side of the circuit will **turn off**.

Short Circuit Isolator - Operating Description:

When a short circuit event occurs the loop controller goes into a current limiting condition then disconnects the line voltage after a short time. The controller will then re-power the line. The loop device shall then power up and reset the isolator to the **open condition** to protect the rest of the circuit. The circuit will attempt to self-heal until normal circuit conditions resume.

The ASS63LWIPs isolator is a low side isolator. It works by disconnecting the low side connection between ports when necessary conditions are not met and will only reconnect both sides when the necessary conditions are met. Connection of the isolator is a staged process. Requirements for connection of the isolator are:

1. The input port and output port voltages must be above V connect min (**24-28 V DC**) The output port voltage is obtained by a small test current being placed on the output port.
2. One port must have communications up as dictated by the protocol requirements. If neither port has a valid communications connection, then the isolator will not reconnect.

Installation guide

Disconnection of the isolator occurs under either of the following conditions:

1. The input port or output port voltages fall below V disconnect min (**22-26 V DC**)
2. Loss of a valid communications to the Master.
3. There is a short circuit present.

Short Circuit Events:

In the event of a short circuit occurring on any part of the Warden Handset loop circuit the short circuit isolator

circuitry within each Warden Handset (and or the LILC) will activate to disconnect the connections between it and the next Warden Handset. By doing so this preserves the functionality of each Loop Warden Handset and the associated EAID inputs until the circuit issue is restored to normal.

Minimum line operating voltage tolerances are also necessary so that both LEDs operate normally as explained above.

2. Board Features & Connections

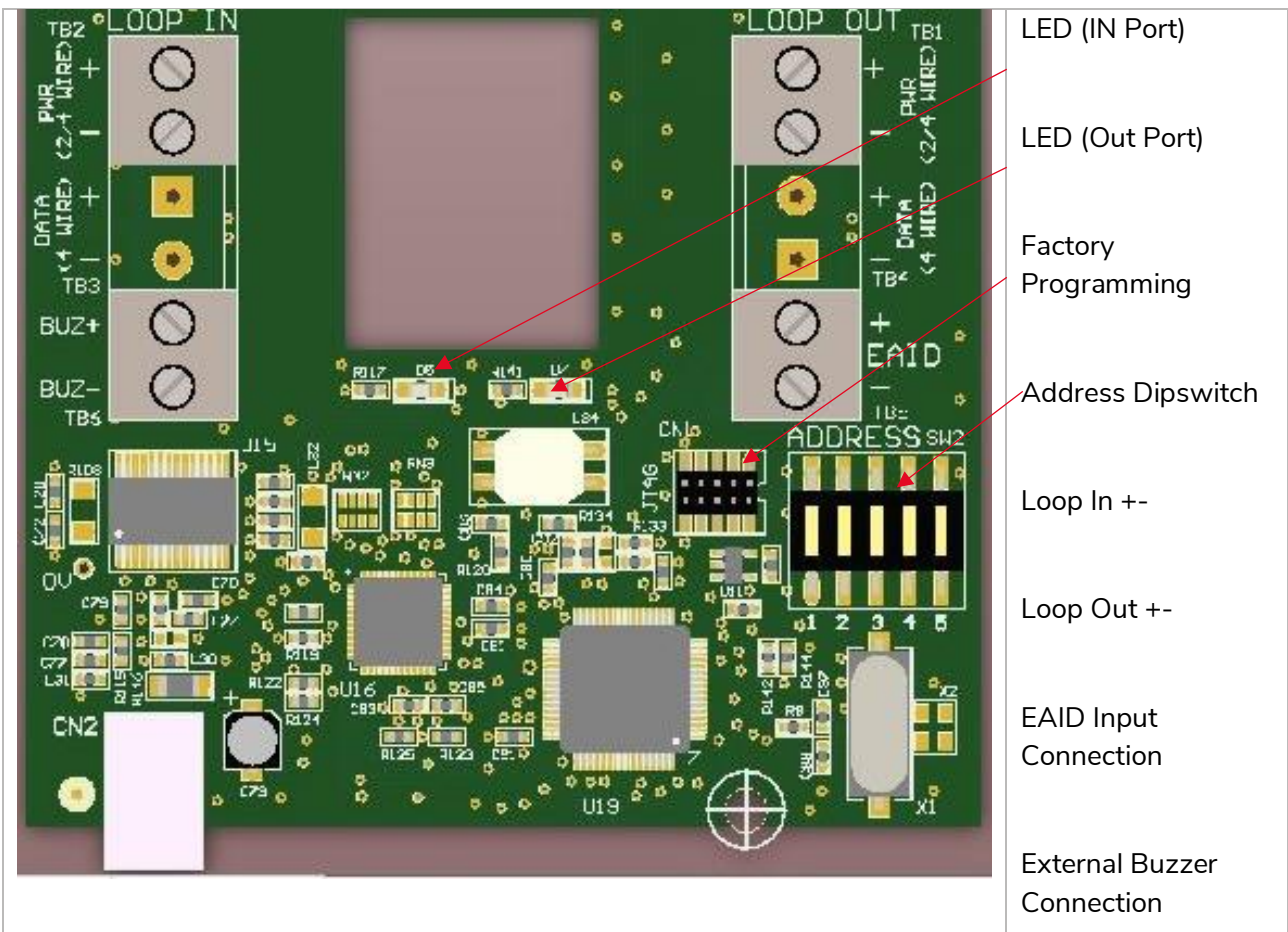

The address dipswitches 1 to 5 from left to right each equal address settings 1-2-4-8-16 respectively

Setting address 20 = Both Dipswitch 5 and 3 (16+4) will be placed in the ON (Up Position)

Addressing starts from address 1

Batch No

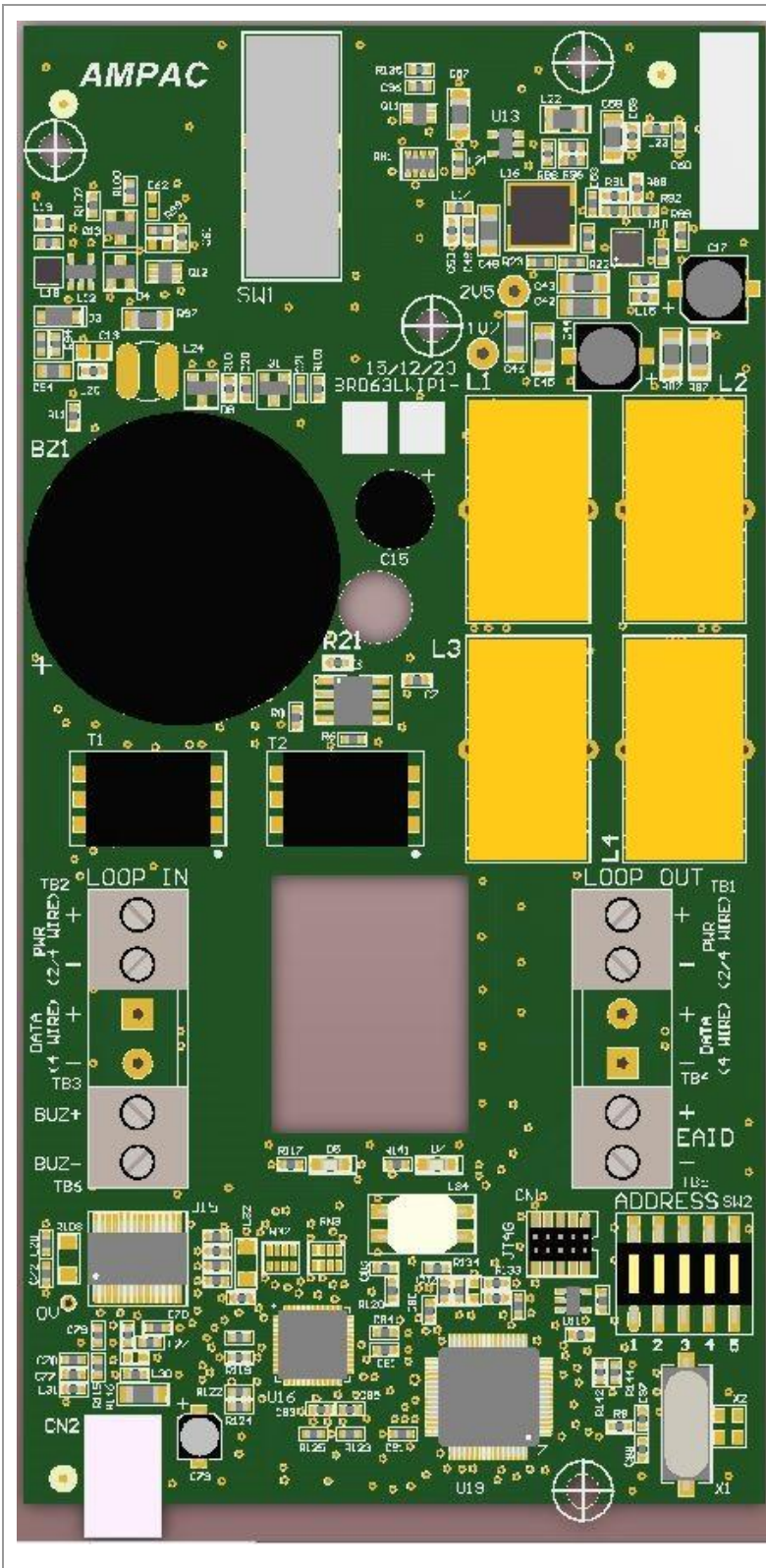

Loop IN LED Status Indicator (IN PORT)

ON & STEADY = Sufficient Voltage 48 V DC and Communications from the LILC is present (Normal)

Note: With loop cabling – Both the IN- and OUT port LEDs will be ON under normal conditions

OFF: card not receiving sufficient power (Line Voltage low)

OR

A Short Circuit is present and the circuit isolator has opened disconnecting the line to protect all Warden Handsets on the loop

FLASHING = Comms originating from the LILC is lost

Loop OUT LED Status Indicator (OUT PORT)

STEADY Board is operating normally, no faults

OFF: The card is not receiving sufficient power (Line Voltage Low)

OR

A Short Circuit is present and the circuit isolator has opened disconnecting the line to protect all Warden Handsets on the loop

FLASHING = Comms originating from the LILC is lost

All LEDs off

Insufficient Power

OR

Loop Warden Handset is not programmed

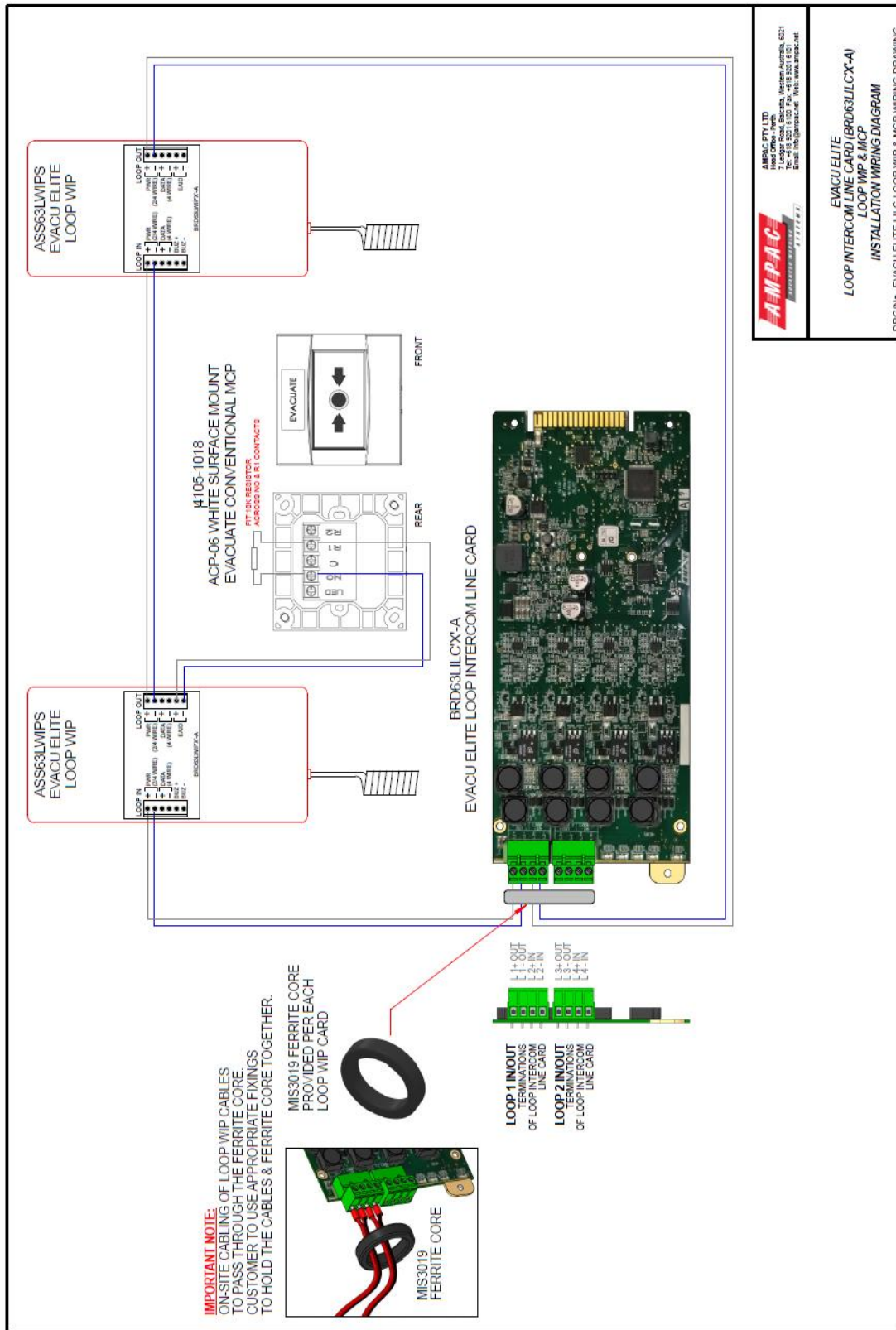

Field Wiring - Use of Ferrites on Each Loop WIP Card Note: Two x MIS3019 ferrite core items are packed with each Loop WIP Card (6350-LILC). It is necessary to connect the ferrites on each loop circuit as shown in the drawing below.

Installation guide

3. User Interface Features

Select **MENU** then select **NODES**. Select the **LILC ICON** which is a *'phone inside a circle'*. Selecting this ICON will allow you to review status of hardware and software versions and the condition of each Loop status. The individual Loop address can also be seen from a respective panel screen.

In a normal condition Loop circuit one side of the loop connection reads **ACTIVE** and the other side reads **INACTIVE**

If physical breaks in the loop circuit exist the system will enter a **general fault condition**. By Interrogating **MENU & FAULTS** the user interface screens will indicate between which two addresses (and related config EIS zone numbers) the actual circuit break exists. This is also true when a short circuit event is present when the isolator changes state to **open the circuit**.

4. Testing Method for Loop Warden Handset Short Circuit Isolators

Remove the Loop Warden Handset cover. Remove the loop cable from the IN port on one handset. Carefully join the 2 cores together (positive and negative) to introduce the short circuit condition.

You will observe the LED on the affected side port no longer functions as normal but all Warden Handsets on the loop circuit will remain fully functional. A general fault will indicate on the common system LEDs on the EWCIE.

5. Loop Cabling and LILC Characteristics

Parameter	Detail
No. of Loop Interfaces	2
Warden Handsets per Loop	20
MCPs per Warden Handset	1
Loop Length	1 km (max)
Signalling	Proprietary modulated digital over power
Loop Cabling	2 core unshielded twisted 1.5mm ²
Max Distance Between Warden Handsets	500m
No. of Racks Slots	1
LILC Current Consumption at 24 V	0.068 Amps (Quiescent – with no phones connected), 0.420 Amps (20 phones connected to 1 loop) 0.770 Amps (40 phones - 20 phones x 2 loops)
Loop Handset Current at 24 V	Idle 0.018 Amps each, During Calls 0.022 Amps each

6. Installation

- a. Mount the Warden Handsets vertically on the wall using suitable screw fixings.
- b. Set the dipswitch address's (between 1-20) to match the loop configuration.
- c. Connect the loop cabling in and out. Be sure to maintain correct polarity throughout the circuit.
- d. Connect EAIDs if fitted as per the schematic drawing.
- e. The system configuration will need loading into the panel before testing can commence.
- f. Test the functionality.
- g. Ensure the LILC installation guide has been followed in conjunction with this.

For Item E please refer to the **Programming Manual MAN3142**