

Fire detection and evacuation solutions that save lives.

Ceiling Speaker with Metal Grille

Features

- Stylish aluminium grille
- Low profile design
- Tuned PA driver designed to meet fire standards
- Fire resistant ABS safety cover
- One-Shot 'snap-fit' mounting
- Excellent speech intelligibility
- High quality speaker driver
- Compression glands supplied

Description

The ceiling mount speakers certified to the AS ISO7240.24 standard for fire & evacuation announcements in buildings.

Each speaker is fitted with a fire retardant speaker/transformer dome and is fitted with oversized cable glands and terminal blocks for easy on site termination. The speaker utilises the One-Shot 'snap fit' mounting system.

Dimensions (mm)

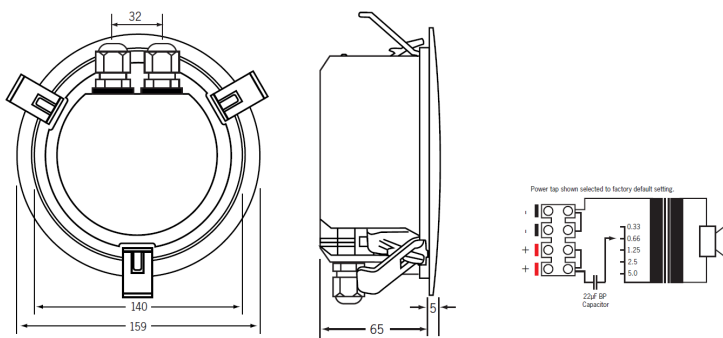

Specifications

Rated Noise Power	5 Watts (100V line)
Power Taps & Impedance (100V line)	0.33W (30kΩ), 0.66W (15kΩ), 1.25W (8kΩ), 2.5W (4kΩ), 5W (2kΩ)
Sensitivity	89dB (1W @ 1m), 77dB (1W @ 4m)
Maximum Sound Pressure Level	96dB (5W @ 1m), 84dB (5W @ 4m)
Frequency Response	100Hz - 15kHz
Coverage Angle (-6dB)	1000Hz: 180°, 2000Hz: 160°, 4000Hz 75°
Environmental Type	A (for indoor applications as per standard)
Speaker Component	100mm (4") paper cone speaker
Mounting Hole	140mmØ
Mounting Method	3 x plastic spring loaded clip
Line Monitoring	Yes, 22µF bipolar capacitor
Applicable Cable	2.5mm ² (14AWG) max conductor area
Connection	4 way screw terminal
Finish	White or black flame retardant ABS basket (ABS AF312C) Clear Flame retardant ABS spring clips (Makrolon 6557) Red flame retardant ABS transformer dome cover (Starex VH-0800) Powdercoated aluminium grille insert
Dimensions	159mm Ø x 65mm D
Weight	710g

Item Numbers

4113-1016 Ceiling Speaker White Aluminium Grille

4113-1017 Ceiling Speaker Black Aluminium Grille