

Switch & Indicator Card

Item Number: 4310-0030

Installation guide

Description

Controls and monitors ancillary equipment
 Eight (8) push on / push off switches per card
 Switches map to relays – requires Relay Board (Order Code: 4310-0050)
 One (1) status indicator per switch – requires Input Board (Order Code: 4310-0040)
 Programmed via the FACP front panel
 The Switch Indicator Fast Card Fit Kit consists of:

- 1 x BRD25GIBB-'X'
- 1 x 220mm and 350mm RJ45M Comms cable

Installation

Observe anti-static precautions at all times

1. Power down and disconnect the batteries.
2. One Switch and Indicator Card per FACP is designed to clip into the front panel of the FACP.
3. From inside the FACP remove the blank panel by depressing the 2 top and bottom retaining clips while at the same time pushing it out through the front panel. Insert labels and clip in the Switch Indicator Card.
4. Select a suitable cable length from those supplied to connect CN1 of the module to the CN9 of the Main Card or, CN2 of the previous front panel card.
5. Power up, connect the batteries, program and test.

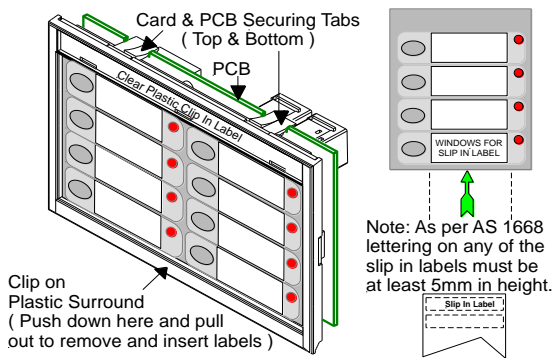

Figure 1: Switch & Indicator Card (See LAB1483.doc for Slip In Label)

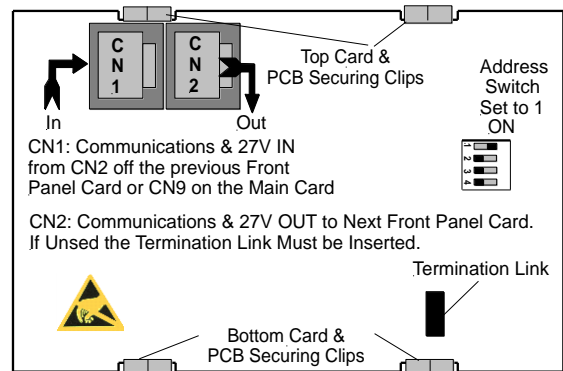

Figure 2: Switch & Indicator Card PCB Layout

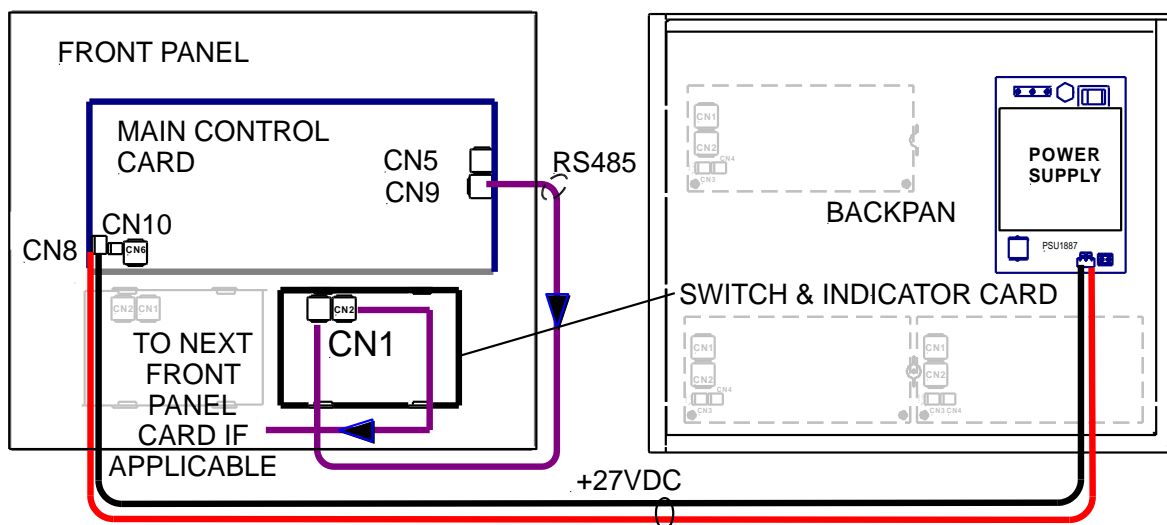

Figure 3: Typical Switch and Indicator Card Cabling to the Main Control Card