

Fire Fan Module AS

Item Number: 4310-0021

Installation guide

Description

Each Fire Fan Module houses the control and indication of up to four (4) fire fans and a single control/indication for plant trip reset.

A hard-wired version of a fire fan module consists of a Fire Fan Control Card and Termination Board. Field wiring is terminated to the termination board at the FACP.

A loop-driven version is also available and, in this configuration, only the Fire Fan Control Card would be required. Field wiring will terminate to address input/output devices that operate on the addressable loop.

Both versions support the plant trip reset – which is a separate reset facility to the master reset the front of the FACP.

The Fire Fan Module Fast Fit Kit consists of;

- The Fire Fan Card.
- The Fan Termination Board and power cable.
- 1 x 220mm and 350mm RJ45M Comms cable.
- 8 x Mounting screws and 4 X standoffs.

Installation



Observe anti-static precautions at all times

Fan Control Board

The Fan Control Board is designed to clip into the front panel of the FACP.

1. Power down and disconnect the batteries.
2. From inside the FACP remove the blank panel by depressing the 2 top and bottom retaining clips while at the same time pushing it out through the front panel.
3. Insert labels and clip the Fan Control Module in its place. (See LAB1486.DOC for slip in label)
4. Set the address switch to the appropriate address (1 – 15) and insert the termination link (LK1). Ensure the Termination card (if used) is set to the same address as the Controls.
5. Select a suitable cable length from those supplied to connect
6. CN1 of the Card to the FACP Main Card or, CN2 of the previous front panel card of the FACP.
7. Power up; connect batteries, program and test

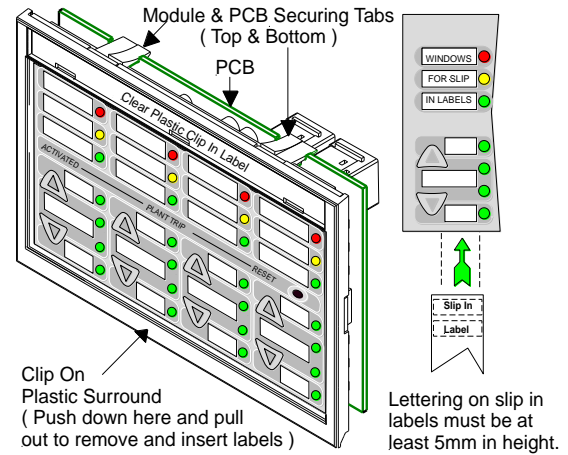

Figure 1: Fan Control Board

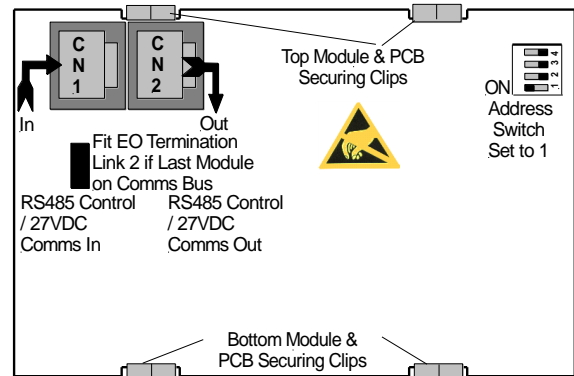

Figure 1: Rear View Fan Control Board

Fan Termination Board

ZoneSense Plus Example Installation

ABS Cabinet

1. Mount the board onto the stand offs, see Figure 4 for locations, using the 4 M3 X 8mm screws

Metal Cabinet (standoffs fitted to lower left hand side)

1. If necessary fit the stand offs to the right hand side position.
2. Set the address to 1 then mount the board onto the standoffs using the 4 M3 X 6mm screws
3. Select suitable cable lengths from those supplied to connect to the Main Card as shown below.
4. Power up, reconnect batteries, program and test

Installation guide

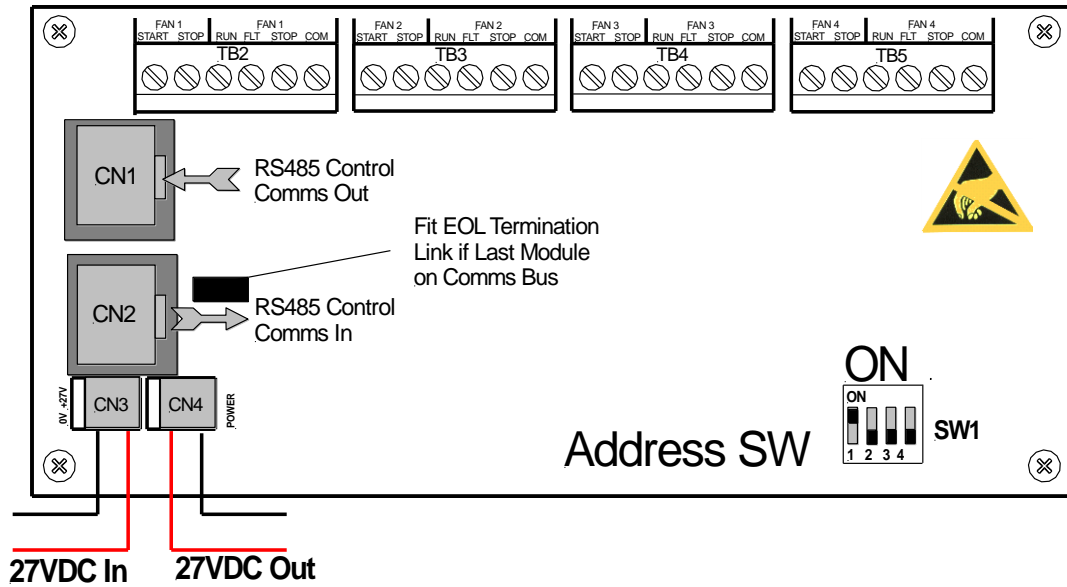

Figure 3: Fan Termination Board and General Wiring

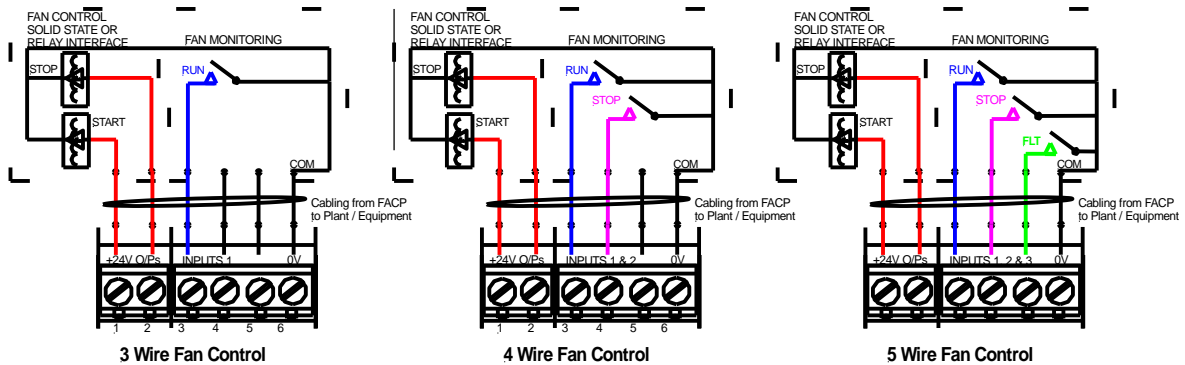

Figure 4: General Wiring For a 3, 4 and 5 Wire Setup

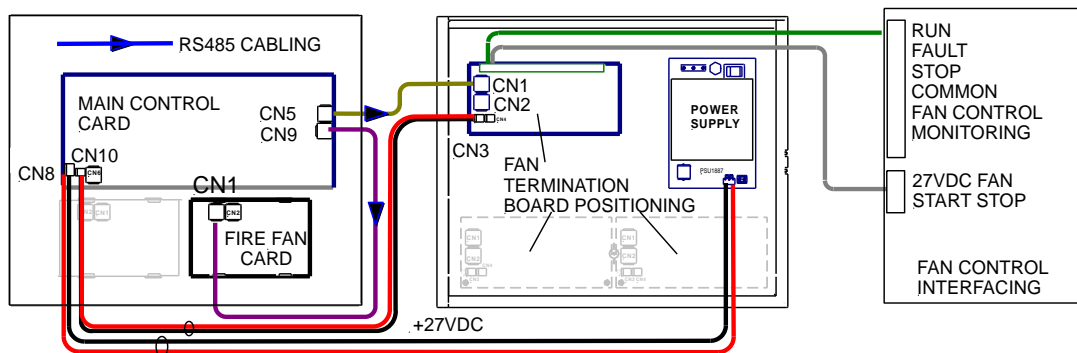

Figure 2: ZoneSense PLUS Fire Fan Module and Typical Internal / External FACP Cabling Example