

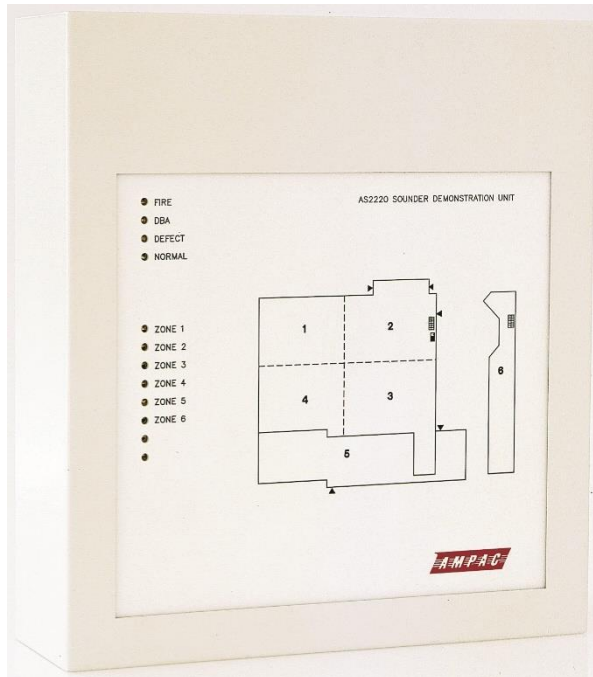

Fire detection and evacuation solutions that save lives.



NZ3200

Fire Alarm Control Panel (NZS4512:2003)

Installation, Commissioning & Operation

MAN 2338-3

Contents

1	System Description	4
1.1	General Description.....	4
1.2	System Layout.....	4
1.3	Main System Board 302-7080	6
1.3.1	Main Board Terminal and Connector Summary	7
1.3.2	Detector Circuits TB5 & TB6.....	8
1.3.3	Bell Circuits TB4.....	8
1.3.4	Bell Isolate (Internal)	8
1.3.5	Self Test.....	8
1.3.6	Walk Test.....	8
1.3.7	Door Interlock	9
1.3.8	Fault Indicators.....	9
1.3.9	DBA Input TB2	9
1.3.10	Power Supply.....	9
1.3.11	Mains On Indicator	9
1.3.12	Ancillary Power Output TB1	10
1.3.13	Fusing.....	10
1.4	Zone Board 302-5880	11
1.4.1	Detector Circuits.....	11
1.5	Batteries	11
2	Connecting Devices	12
2.1	Detectors.....	12
2.1.1	Detector Limitations	13
2.1.2	Manual Call Points.....	13
2.2	Bells and Sounders.....	13
3	Connecting The Evacuation Amplifier	15
3.1	Overview:	15
3.2	Specifications:.....	15
3.3	Operation:	16
3.4	Installation Criteria	16
4	Connecting Brigade Interfaces	19
4.1	Connecting a Signal Generating Device	19
5	Settings	20
5.1	Main System Board (302-7080) Settings.....	20
5.1.1	Setting the Number of Zone Cards	20
5.1.2	Miscellaneous Settings	20
5.1.3	Setting Zone Bell Output.....	21
5.1.4	Setting Zone Brigade Call Output	21
5.1.5	Allocating AVF to a Zone	21
5.2	Zone Card (302-5880) Settings.	21
5.2.1	Setting the Address of the Zone Cards.....	22
5.2.2	Setting Zone Bell Output.....	22
5.2.3	Setting Zone Brigade Call Output	22
5.2.4	Setting Zone Configuration	22
6	Specifications	23
7	Installation And Initial Operation	24
7.1	Unpacking And Inspection	24

7.2	Anti Static Precautions	24
7.3	Installing the NZ3200	24
7.4	Removing and Reinstalling the Index Panel	24
7.5	Initial Operation.....	24
8	System Operation.....	25
8.1	Resetting the System	25
8.2	Isolating the Bells/Sounders.....	25
8.3	Using the Walk Test Facility	25
8.4	Self Test Facility	25
8.5	Evacuation	25
9	Options.....	26
9.1	ASPI Relay Board.....	26
9.1.1	Description	26
9.1.2	Settings	26
9.1.3	Installing the ASPI Relay Board.....	26
9.2	8 Way Relay Board	27
9.2.1	Description.....	27
9.2.2	Connections	27
9.2.3	Technical Specifications	27
9.2.4	Communications.....	27
9.2.5	Interface Relays	28
9.2.6	Link Settings	28
9.2.7	Programmable Relays	30
9.3	LED Mimic Driver Board	31
9.3.1	Description.....	31
9.3.2	Specifications	32
9.3.3	Installation	33
9.3.4	Component Layout	35
9.4	24 Volt Bell Driver Board	37
9.4.1	Description.....	37
9.4.2	Features	37
9.4.3	Specifications	37
9.4.4	Connections	37
10	Troubleshooting	39
11	Index Panel Engraving	40
11.1	NZ3200/16 without DBA. For rear service FACP	40
11.2	NZ3200/16 with DBA . For rear service FACP	41
11.3	NZ3200/16 For front service FACP	42
11.4	NZ3200/32 For Rear service FACP	43
11.5	NZ3200/32 For Rear service FACP	44
12	Appendix A. Battery Calculation.....	45
13	Appendix B. Example Battery Calculation	46
14	Appendix C: Devices	47

1 System Description

1.1 General Description

The NZ3200 is available in two standard formats - the NZ3200/16 and the NZ3200/32. The NZ3200/16 accommodates the 302-7080 Main System Board, and one, eight-zone circuit board (302-5880) giving a total of 16 circuits. These circuits can operate with smoke detectors, heat detectors and manual call points. The NZ3200/32 panel accommodates the 302-7080 Main System Board, and up to three eight-zone circuit boards (302-5880) giving a maximum capacity of 32 circuits. Various options are available for both formats. These are listed in the Appendix Compatible Devices.

1.2 System Layout

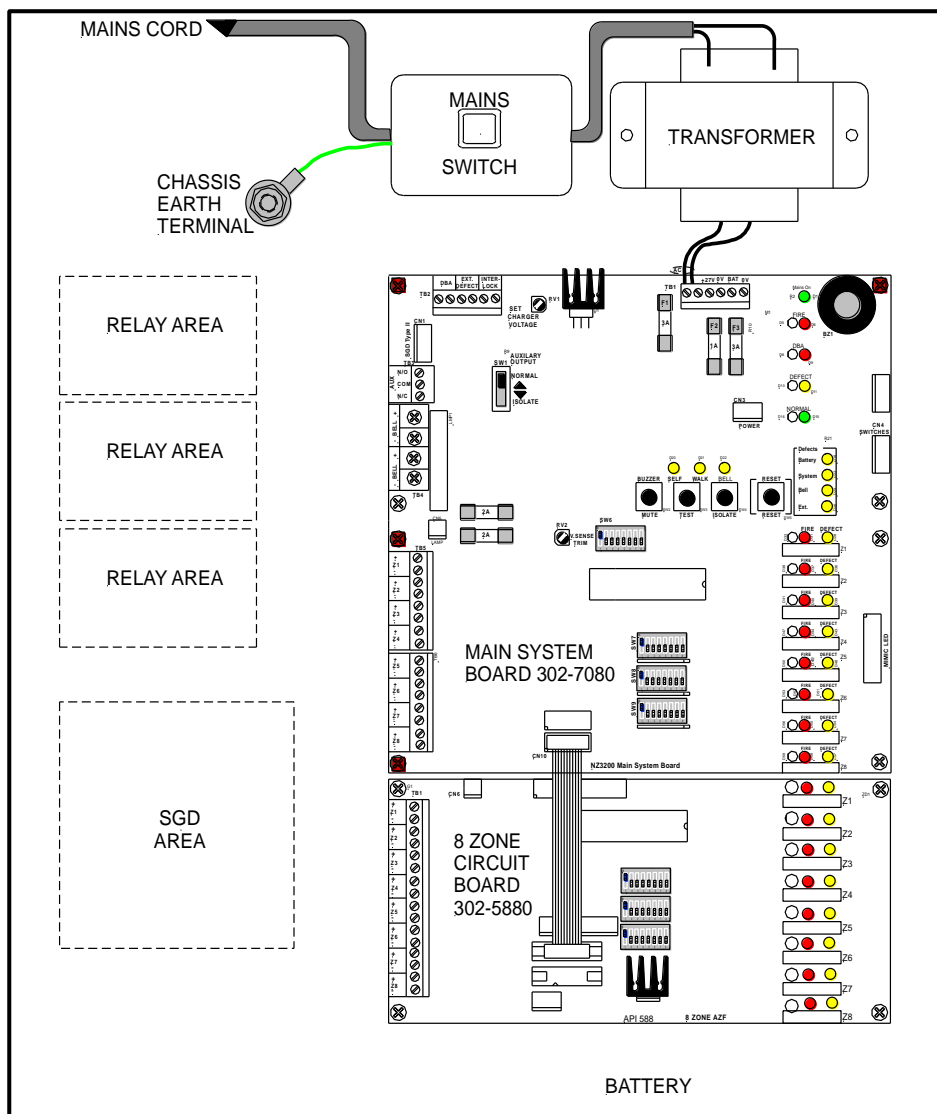

Figure 1: NZ3200/16 System Layout

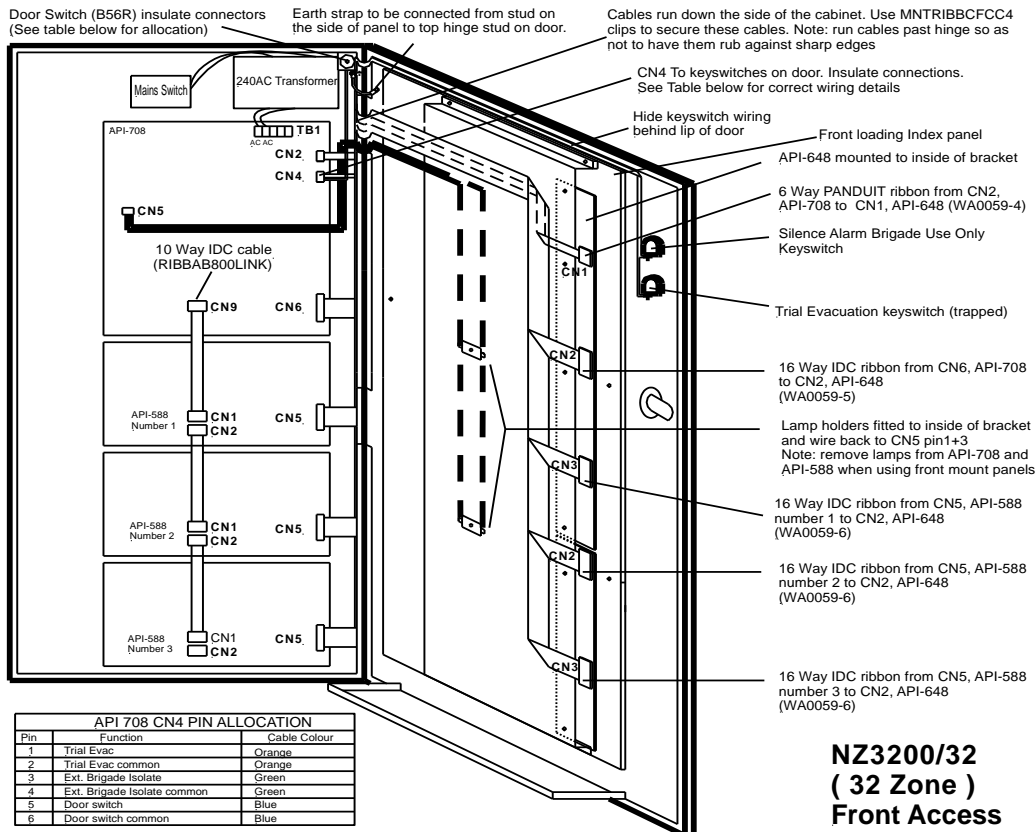
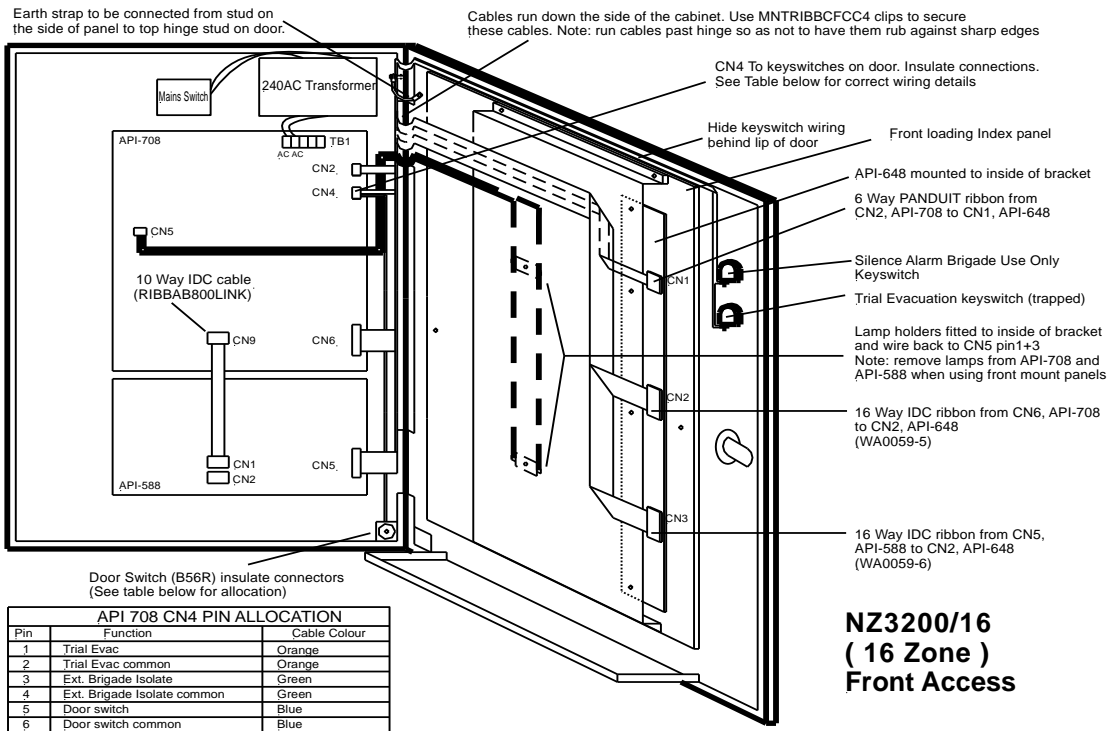

Figure 2: Examples of 16 and 32 Zone Front Access FACP's

1.3 Main System Board 302-7080

The Main System Board provides most of the functions and common connections required by the NZ3200 system and the first eight zones.

The 302-7080 provides the following:

- Bell circuits.
- SGD connections.
- Controls - Reset, Bell Isolate, Test, Buzzer Mute Aux Relay Isolate, Trial Evacuation and Brigade Silence Alarm.
- System status indication.
- Power supply.
- Eight zone circuits.

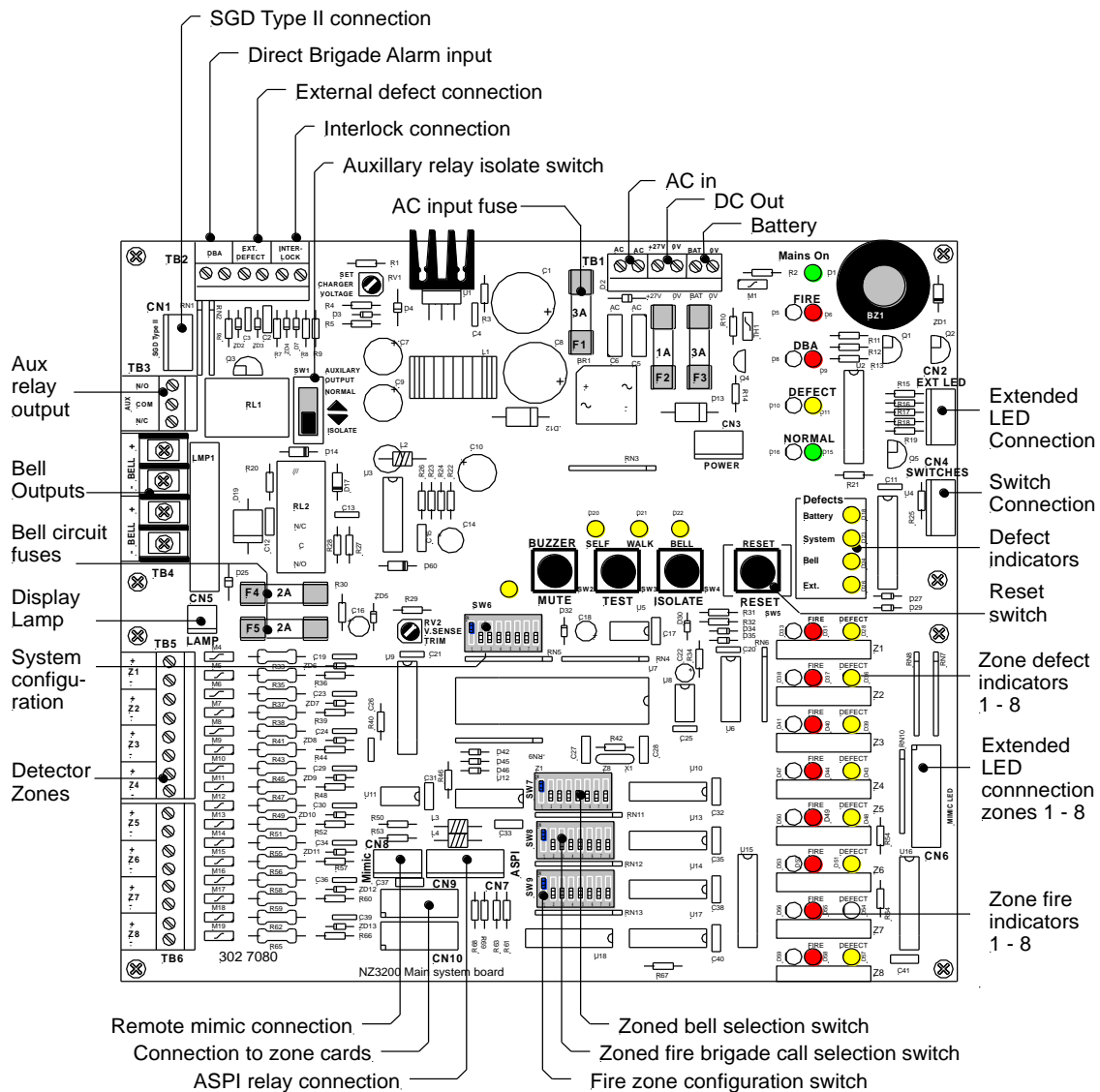

Figure 3: 302-7080 Main System Board

1.3.1 Main Board Terminal and Connector Summary

Screw Terminal Blocks

TB1 Power

- 1 27VAC In
- 2 27VAC In
- 3 +27 volts Out
- 4 0 volts Out
- 5 Battery +ve
- 6 Battery -ve

TB3 Auxiliary Relay Output

- 1 Auxiliary Normally Open RL1 Relay Contact
- 2 Auxiliary Common Relay RL1 Contact
- 3 Auxiliary Normally Closed RL1 Relay Contact

Plug In Connectors

CN1 SDG Connection

- 1 +5 volts
- 2 Fire
- 3 +5 volts
- 4 Defect
- 5 Interlock
- 6 0 volts

CN3 Auxiliary +27 Volts

- 1, 5 0 volts
- 3 + 27volts
- 2, 4 No Connection

CN5 Lamp

- 1 Lamp +ve
- 2 No Connection
- 3 Lamp -ve

CN8 Remote Mimic

- 1, 2 Line A, Line B
- 3, 4 Control
- 5 0 volts

CN7 ASPI Relay Connection

- 1 Data Out
- 2 No Connection
- 3 Clock
- 4 +27 volts
- 5,6,7 Address
- 8 0 volts

TB2 External Other

- 1 DBA +ve
- 2 DBA 0volts
- 3 External Defect +ve
- 4 External Defect 0 volts
- 5 External Switch Interlock +ve
- 6 External Switch Interlock 0 volts

TB4 Bell Outputs

- 1 Bell 1 Output +ve
- 2 Bell 1 Output -ve
- 3 Bell 2 Output +ve
- 4 Bell 2 Output -ve

CN2 Extended LED's

- 1 +27 volts
- 2 Fire LED
- 3 DBA LED
- 4 Defect LED
- 5 Normal LED
- 6 0 volts

CN4 Door Controls

- 1 Trial Evacuation
- 2, 4, 6 0 volts
- 3 Ext Switch
- 5 Door Switch

CN6 Extended LED's Zone 1 – 8

- 2 Zone 1
- 4 Zone 2
- 6 Zone 3
- 8 Zone 4
- 10 Zone 5
- 12 Zone 6
- 14 Zone 7
- 16 Zone 8

CN9, CN10 Internal Comms

- 1 Reset System
- 2,4,6,8,10 0 volts
- 3 Line A
- 5 Line B
- 7, 9 + 27 volts

1.3.2 Detector Circuits TB5 & TB6

The 302-7080 provides connection to eight zone circuits. All of the detector circuits can be configured to accept smoke detectors, heat detectors, manual call points or a combination of these devices. Detectors or manual call point types used are subject to the compatibility limitations.

Devices such as smoke detectors, which signal by increasing line current, can, when signaling, go through an optional Alarm Verification Facility (AVF). As such, when a detector goes into alarm, it is reset and not monitored for six to seven seconds, if an alarm is still present after this time, the system will latch into alarm. This function may be de-selected if desired in groups of two.

1.3.3 Bell Circuits TB4

The NZ3200 provides a monitored bell circuit split to drive two x 2Amp circuits. These circuits each require a 10K EOL resistor to give a system normal indication. If circuit is open or shorted, a defect signal is generated and the “Bells Fault” LED is illuminated.

See section 4 for connection details.

1.3.4 Bell Isolate (Internal)

This facility is set or reset by alternate pushes of the bell isolate switch. The yellow LED above the internal bell isolate switch indicates when the bell is isolated. When the bell is isolated, the bell relay will not respond to fire conditions thus enabling the system to be tested without disturbing the building occupants. This switch is monitored, see section 4.3.6.

1.3.5 Self Test

Pressing the “Test” button twice activates this function. This causes the unit to test each zone sequentially by placing it into alarm and defect conditions. When it has completed this test, it will automatically return to its normal mode of operation. This self-test may be terminated at any time by another press of the switch.

During the self test the Fire, Defect and Bell outputs are inhibited.

1.3.6 Walk Test

This function is initiated by pressing the “Test” button once on the Main System Board. When this button is pressed a LED directly above the switch indicates. While the panel is in the walk test mode the detectors can be operated in the field and the panel will automatically reset them after a period of four seconds. During the test the bell output and brigade output will operate as normal. To prevent an unnecessary fire call it is recommended to isolate the brigade. To restore the panel to normal operation simply repress the switch and the walk test indicator will turn off. This switch is monitored, see section 4.3.6.

1.3.7 Door Interlock

If any of the monitored switches as listed below within the NZ3200 are not in their normal state when the door is closed the buzzer will sound to alert the operator to this condition. If the condition is not rectified within two (2) minutes then a defect is signaled.

The following switches are monitored: Isolate, Test, AUX Relay Isolate, Walk Test and Internal Bell Isolate. If the Walk Test or Internal Bell Isolate are active when the door is closed, they automatically return to their normal state after forty seconds.

Provision is also made for auxiliary switches to be wired into the door interlock warning system via the interlock input on the Main System Board.

1.3.8 Fault Indicators

Fault indicators are provided on the Main System Board for the following.

- (a) Battery Fault. This indicates if the battery voltage is below 24.3 volts.
- (b) Bell Fault. This indicates an open or short circuit on bell line/s.
- (c) System Fault. This indicates one of the following:
 - Communications fault.
 - A module is disconnected.
 - The door was closed with a switch not in its normal position. See section 4.3.6.
- (d) External defect
- (e) Zone defects (eight of)

1.3.9 DBA Input TB2

An input is provided for connection to any external device providing a Direct Brigade Alarm (DBA) output, eg sprinkler systems. A short circuit on this line will cause the DBA LED to light and the system bells to be energised. This input is monitored for normal condition with a 10K resistor. An open circuit will cause the DEFECT and SYSTEM LED to illuminate and the defect output to be energised.

1.3.10 Power Supply

The Main System Board has an on board switch mode power supply providing 27VDC at 1A for system power and charging the system batteries. The system incorporates a test function, controlled by the CPU on the 302-708, which decreases the power supply output voltage for forty-five minutes, every forty eight hours to check the condition of the system batteries. If the battery voltage falls below 24.3V during the test period a defect signal is generated and the battery fault LED is illuminated.

The system checks that the battery is connected four times a minute using the same test as above except the reduced voltage lasts for half a second.

1.3.11 Mains On Indicator

This LED is illuminated when the main power supply is connected and operational.

1.3.12 Ancillary Power Output TB1

A fused power supply output is provided to power ancillary devices. The output is marked +27V and 0V on TB1.

1.3.13 Fusing

The Main System Board has five fuses:

F1	AC Power supply fuse	3 Amp M205
F2	Power supply output fuse	1 Amp M205
F3	Battery fuse	3 Amp M205
F4	Bell circuit fuse	2 Amp M205
F5	Bell circuit fuse	2 Amp M205

1.4 Zone Board 302-5880

The 302-5880 Zone board provides all the necessary functions to control and monitor eight (8) detector circuits. Up to three 302-5880 zone boards may be fitted to an NZ3200 system (NZ3200/32).

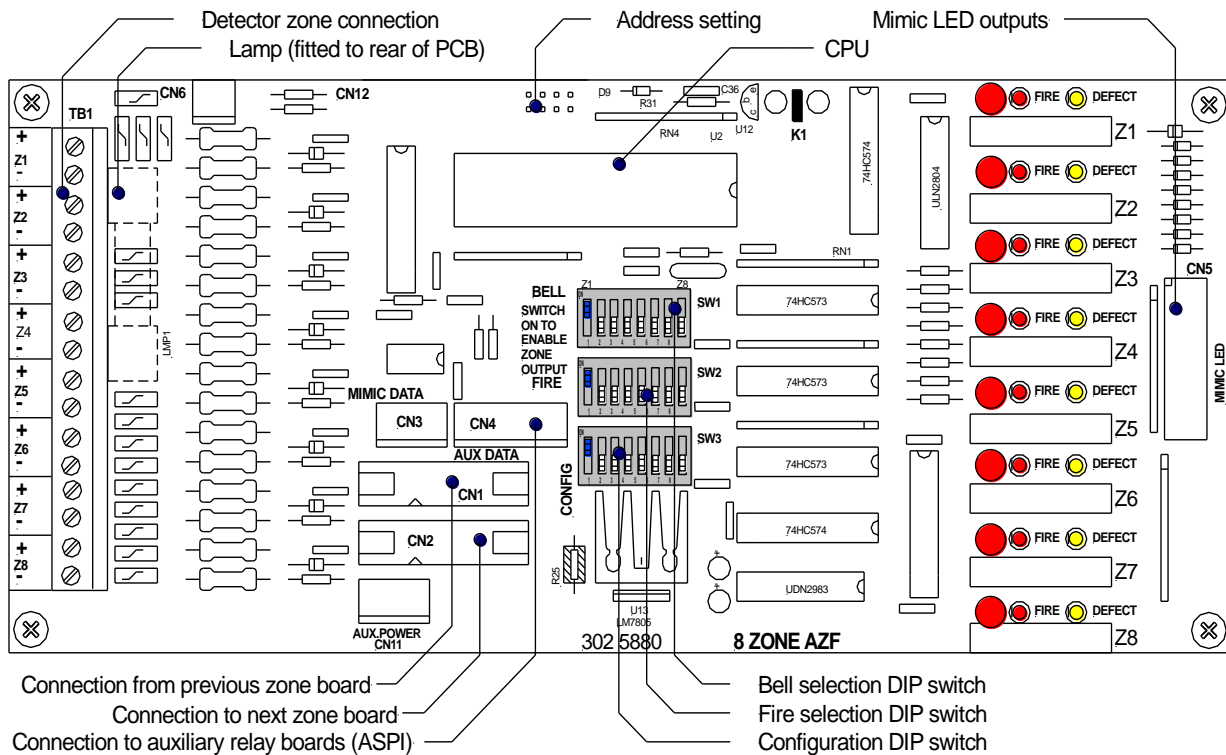

Figure 4: 302-5880 Zone Card

1.4.1 Detector Circuits

The 302-5880 zone board provides eight zone circuits, which operate identically to those provided on the 302-7080 board.

1.5 Batteries

The NZ3200/16 system is designed to accept two x 12V, 7 AH sealed lead acid batteries. These are fitted into the shelf on the inside of the door.

The NZ3200/32 system will accommodate two x 12V, up to 12 AH sealed lead acid batteries. These sit in the base of the cabinet.

See also Appendix A for battery calculations.

2 Connecting Devices

2.1 Detectors

A sample of the detectors approved for use with the NZ3200 are listed below. (See Appendix A)

Detector Type	Iq	Order Code
Apollo Series 65 Ionisation Smoke Detector	45 μ A	55000-217
Apollo Series 65 Photoelectric Smoke Detector	45 μ A	55000-317
Orbis Photoelectric Smoke Detector with Flashing LED	120 μ A	201-0501
Ampac Thermal Detector Blue Indicating	40 μ A	4255-0300
Ampac Thermal Detector Yellow Indicating	40 μ A	4255-0400
Ampac Fireray Beam 2000	8mA	220-0004
Ampac Fireray Beam 50R	4mA	220-0005
Ampac Fireray Beam 100R	4mA	220-0006

Note:

1. Iq = Quiescent Current Draw
2. **The maximum current available for any one Detector Circuit is 4.8mA @ a line voltage of 24VDC.** As a guide to approximately determining the maximum number of detectors allowable on any one circuit, keeping in mind any losses, multiply the Iq of the type/s involved by the number required and if applicable (more than one type involved) add the resultants
3. Rate of Rise Heat Detectors are also available

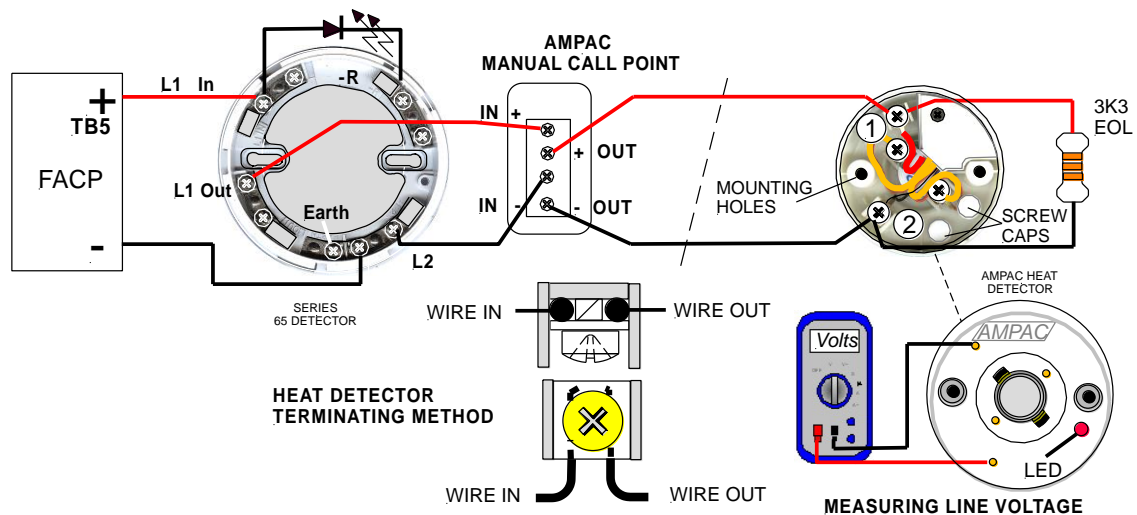

Figure 5: Example of Detector & MCP Wiring

The zone circuit must be terminated with an end of line resistor with a value of 3.3K Ω (2% tolerance or better, power rating 1/4W)

2.1.1 Detector Limitations

1. All indicating heat detectors draw a small monitoring current and this limits the number detectors that can be connected to a given zone circuit.
2. Detectors are **not** intended for use in areas subject to higher than normal corrosive environments or where corrosive gasses may be present.

2.1.2 Manual Call Points

Type	Iq	Order Code
Ampac Manual Call Point	40 μ A	4255-700

Connect as shown above.

2.2 Bells and Sounders

Two bell/sounder circuits are provided, each capable of driving a 2 Amp load. These lines are monitored using a small current in reverse polarity to normal. For this reason it is necessary to connect bells via diodes, 1N4004 diodes are recommended, as shown below. Also observe bell/sounder polarity.

If required these lines can be split to provide three or four bell parallel circuits total, however if this is done the end of line resistor must be changed. See table below for further detail.

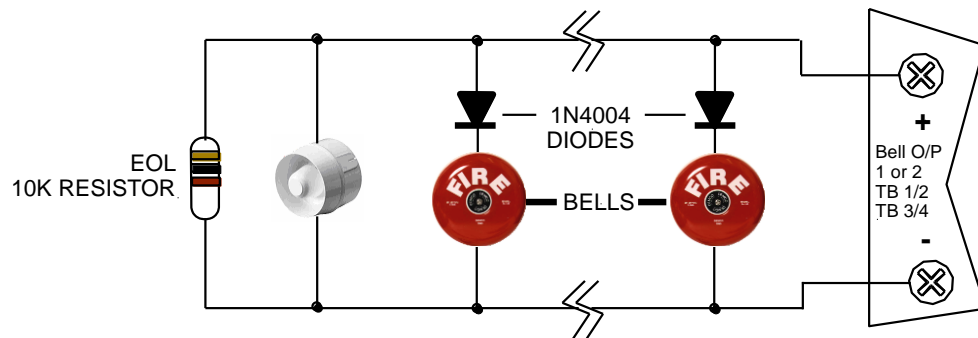

Figure 6: Bell Sounder Connections

	Bell Output 1				Bell Output 2			
	First Circuit		Second Circuit		First Circuit		Second Circuit	
No of Circuits	EOL	Current Available	EOL	Current Available	EOL	Current Available	EOL	Current Available
1	10K	2A	-	-	*10K	-	-	-
2	10K	2A	-	-	10K	2A	-	-
3	22K	1A	22K	1	10K	2A	-	-
4	22K	1A	22K	1	22K	1A	22K	1A

Note: For one bell circuit a 10K EOL is required on the panel on bell output 2.

Compatible Devices

Order Code	Description
206-0002	Bell 24VDC Red 150 mm.
209-0018	Sounder with LED and mute facility.
205-0006	Horn Siren 24VDC 200mA Red .
205-0002	AS2W Flush sounder White 12/24V 15mA .
205-0001	AS2R Flush sounder Red 12/24V 15mA.
205-0009	Vara white
205-0010	Vara red
205-0011	Vector white
205-0013	Viper white
205-0014	Viper red
205-0062	Vantage Sounder AS2220 Evac Tones (Red)
205-0063	Vantage Sounder AS2220 Evac Tones (White
205-0066	Vantage Combi Sounder AS2220 Evac Tones (Red)
205-0067	Vantage Combi Sounder AS2220 Evac Tones (White)

*** Note: These devices do not comply with NZS4512 2003**

3 CONNECTING THE EVACUATION AMPLIFIER

3.1 Overview:

The **EVAC50W24V** is one of a range of 100V-Line Amplifiers. Features include

- ✓ Generation of the 'Alert' and 'Evacuation' tones with verbal messages as specified by NZS4512:2003.
- ✓ capable of driving up to 50W (with a 27.4VDC supply) into 100V PA loud speakers,
- ✓ the 100Vrms output line is overload and short-circuit protected and is monitored by the amplifier circuit with the status transmitted to the panel.
- ✓ controlled through a set of signal (BELL) inputs.
- ✓ may be powered directly from the panel battery or from a separate DC source.
- ✓ when not active (100V line monitoring only) the amplifier draws less than 35mA.
- ✓ an optional microphone input board is available which can be used for public address (PA) or 'Fire Microphone' operation.

3.2 Specifications:

Targeted Panel:	NZ3200.
Board Dimensions:	97mm x 150mm. Height 50mm from bottom of PCB
Mounting Dimensions:	89mm x 130mm.
Operating Voltage:	20 - 29Vdc, nominal 27.4Vdc
Quiescent Current:	30mA RS485: <30mA @ 27.4Vdc
Operating Current:	2.5A @ 27.4Vdc nominal with 50W load.
Power Output:	50W @ 100V line: 27.4Vdc supply – overload and short-circuit protected
Tone:	Evacuation tone and verbal message, compliant to NZS4512:2003 Programmed by using the LED base address dials and program mini-jumpers.
Monitoring:	Fully monitored for open, short circuit or overload (10kΩ, 1W EOL resistor)

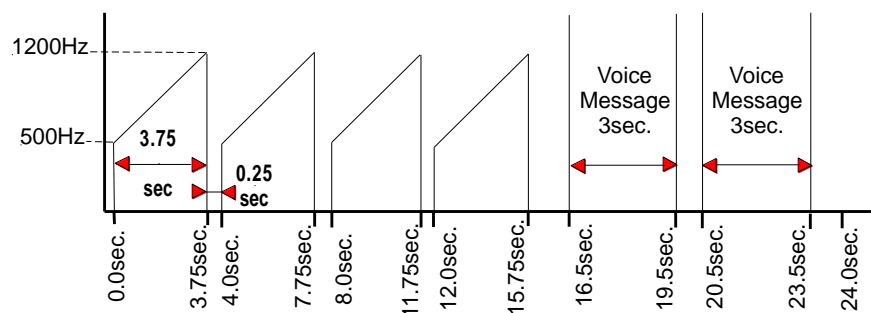

Figure 7: NZS4512 Evacuation Signal with Voice Messaging

3.3 Operation:

The Amplifier is connected to the FACP Bell circuit output as shown in the connection diagrams. Bell terminals '+' and '-' are connected to the corresponding '+' and '-' terminals on the amplifier.

In the 'Normal' state, the FACP monitors the 100V line 10K 1W EOL resistor by applying an inverted voltage to the amplifier input terminals. In this state the amplifier connects the 10K 1W EOL line resistor to the Bell input. A 10K 1W EOL resistor must be used across the 100Vrms line for correct operation of the amplifier monitoring circuit.

In the 'Alarm' state, the FACP reverses the bell voltage causing the amplifier to activate and output a repeating 'Evacuation Tone followed by a voiced Evacuation Message' onto the 100Vrms loudspeaker circuit. The amplifier is NOT monitored during the 'Alarm' state.

If the amplifier output is overloaded, or the supply voltage becomes 'Off-Normal', the amplifier will signal a defect by turning on the Defect/Fault LED (refer Table 1).

Fault LED	ON LED	Defect Description
Off	Off	Amplifier inactive
Off	Steady	Amplifier active
Steady	Flashing	Supply Voltage below 10V or above 15V
Flashing	Steady	Amplifier output is overloaded

Table 1

The 100Vrms Line may have a maximum of three spurs. For these configurations an EOL resistor of the appropriate value must be installed at the end of each spur. (See Table 2).

Number Of Spurs	Number Of Spurs
1	1 x 10K 1W
2	1 x 22K 1W on each spur
3	1 x 33K 1W on each spur

Table 2

3.4 Installation Criteria

- ✓ Capacitively-coupled 100Vrms PA Speakers must be used with the 20W Amplifier. The capacitor must be bipolar and able to withstand 250V peak line voltage. The value should be around 1uF per watt of power for each speaker.
- ✓ 100Vrms speaker wiring must be separated from ELV (Extra Low Voltage) wiring.
- ✓ Loading of the 100Vrms line must not exceed 20W.
- ✓ An excessive load will cause the Amplifier to current limit and shutdown. The symptoms for this may be interruptions in the audio output and two or more amplifiers broadcasting out of synchronization.
- ✓ Loading of the bell output must not exceed the maximum fuse (FACP Bell Circuit Fuse 4 = 2A) or relay (20W Amplifier Line Relay maximum contact current = 3A) rating.

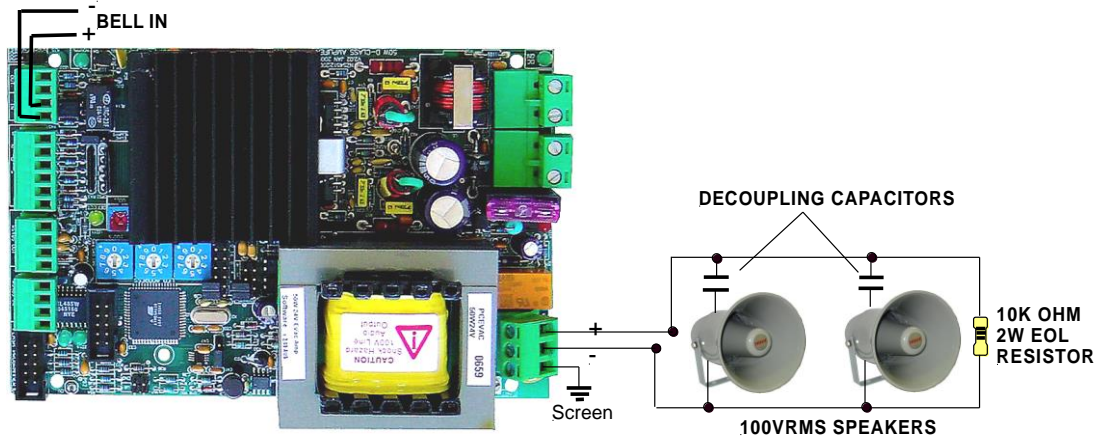

Figure 8: Basic Connection Diagram

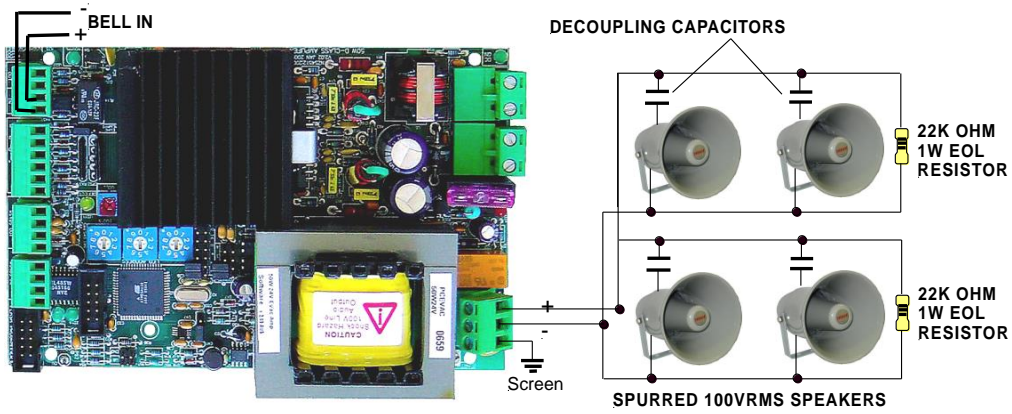

Figure 9: Spurred Speaker Wiring Diagram

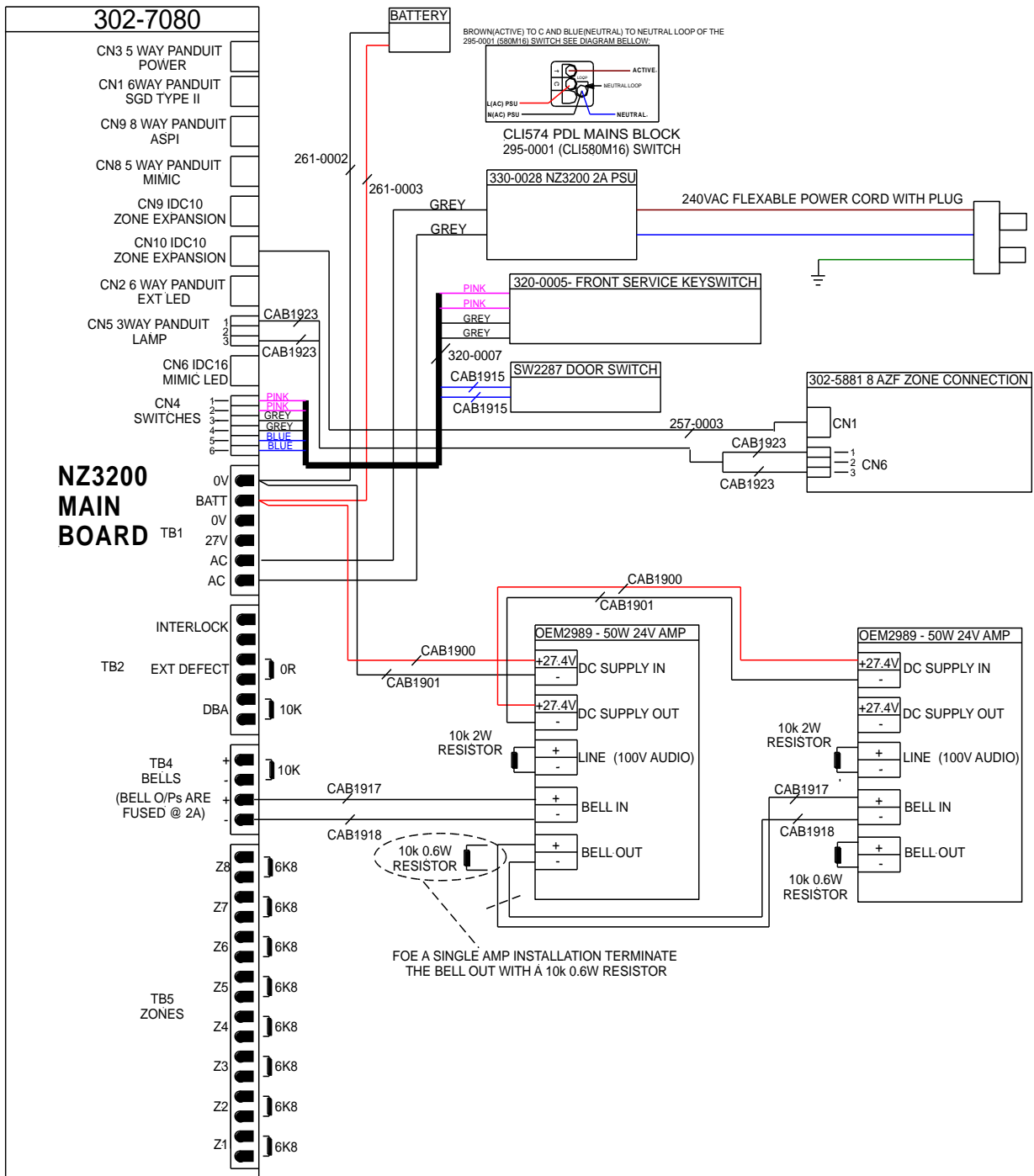

Figure 10: 16 Zone Front Service Cabling

4 CONNECTING BRIGADE INTERFACES

The NZ3200 system allows for connection to the brigade signaling network using a Signal Generating Device (SGD Type II) software version 3.

4.1 Connecting a Signal Generating Device

To install the SGD firstly mount the unit on standoffs within the cabinet as shown below.

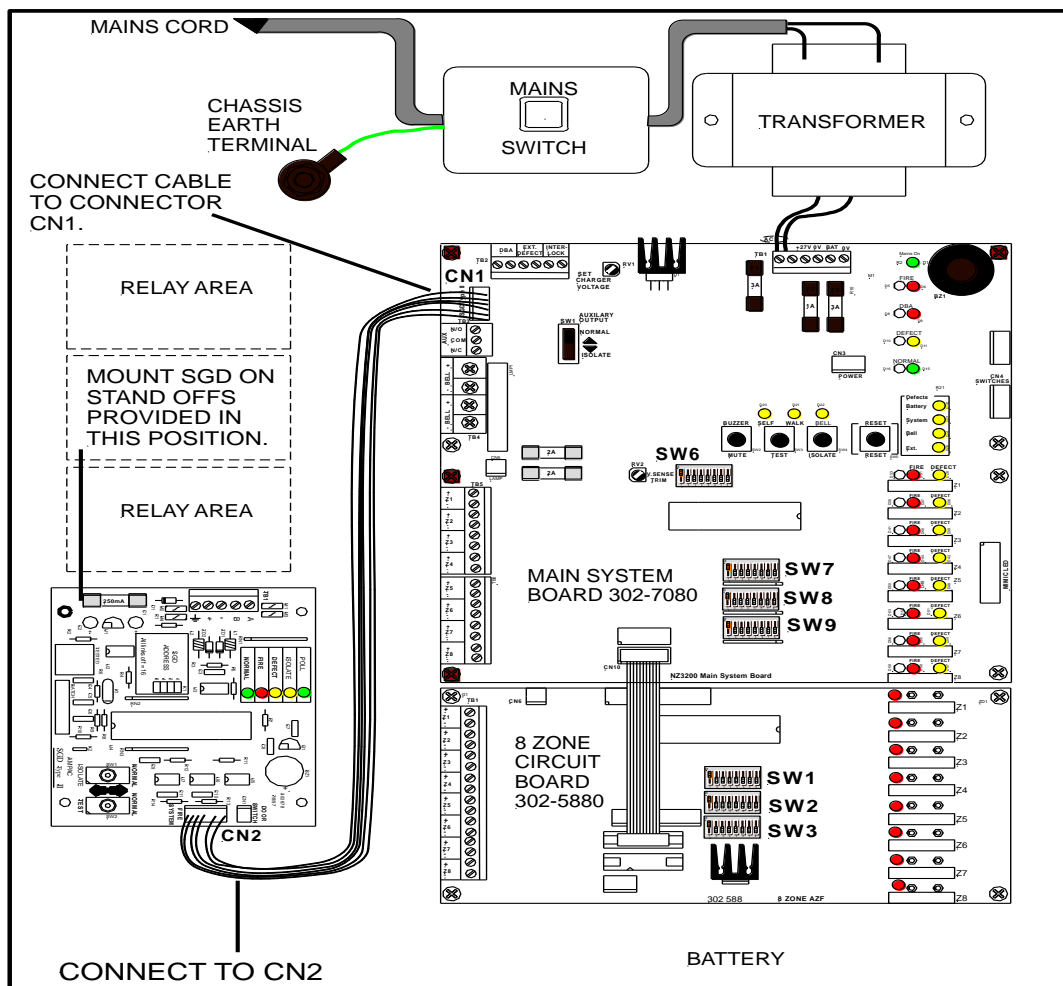

Figure 11: Connecting a SGD II

Connect SGD to the 302-7080 as shown above. All signals required for the SGD brigade signaling are found on connector CN1. The AMPAC Signal Generating Device is supplied with a connection cable. Simply connect one end of the cable to CN2 of the SGD and the other to CN1 of the 302-7080.

Test the monitoring in accordance with the LTX SDG Input Interface Specifications.

5 SETTINGS

5.1 Main System Board (302-7080) Settings

The main system board has four (4) banks of DIP switches which are used to set the following:

- SW6 - Zone cards fitted, monitoring etc.
- SW7 - Zone bell setting.
- SW8 - Zone fire output setting.
- SW9 - Zone configuration.

Note: each switch bank has eight switches. In the following discussion the bank is nominated first and the switch within that bank last. Thus SW6-2 would be the second switch on bank SW6.

5.1.1 Setting the Number of Zone Cards

Switches 1 and 2 of switch bank SW6 set the number of zone cards fitted to the system as shown in the table below.

Number of zone cards	SW6 - 1	SW6 - 2
0	Off	Off
1	On	Off
2	Off	On
3	On	On

5.1.2 Miscellaneous Settings

The remaining six switches in switch bank SW6 set the functions as listed in the table below. Set the switch to the on position to enable the function.

Switch	Function
SW6-3	Direct Brigade Alarm
SW6-4	Bell monitoring
SW6-5	Sound buzzer for defects
SW6-6	Factory use only – Must be set to OFF.
SW6-7	Switch on auxiliary output during trial evacuation
SW6-8	Unused

5.1.3 Setting Zone Bell Output

Each zone on the 302-7080 may be selected to either sound or not sound the bells when in alarm. To set a zone to sound the bells set the DIP switch on bank SW7 to on. For example to set zone two (2) to sound the bells when in alarm set SW7- 2 to on.

5.1.4 Setting Zone Brigade Call Output

Each zone on the 302-7080 may be selected to either call or not call the brigade when in alarm. To set a zone to call the brigade set the DIP switch on bank SW8 to on. For example to set zone two (2) to sound the bells and call the Brigade when in alarm set SW8- 2 to on.

5.1.5 Allocating AVF to a Zone

AVF on each zone on the 302-7080 may be set to be either ON or OFF. To set a zone to have AVF set the DIP switch on bank SW9 to ON. For example to set zone two (2), four (4), six (6) and eight (8) to have AVF when in alarm set SW9- 2, 4, 6, & 8 to ON.

Zone AVF	SW9	Setting
Zone 1	1	Off
Zone 2	2	On
Zone 3	3	Off
Zone 4	4	On
Zone 5	5	Off
Zone 6	6	On
Zone 7	7	Off
Zone 8	8	On

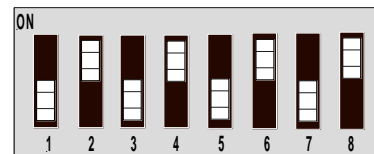

Switch 9 set to above example

5.2 Zone Card (302-5880) Settings.

The zone card has three (3) banks of DIP switches which are used to set the following:

- SW1 - Zone bell setting.
- SW2 - Zone fire output setting.
- SW3 - Zone configuration.

Also a set of four jumper pins is used to set the address

5.2.1 Setting the Address of the Zone Cards.

For the zone card to function correctly the address must be set using the address jumpers which are found immediately above the micro-controller. Each card in the system must have a unique address.

Address	Setting
1	 <input type="checkbox"/> <input type="checkbox"/> <input type="checkbox"/>
2	<input type="checkbox"/> <input type="checkbox"/> <input type="checkbox"/> <input type="checkbox"/>
3	<input type="checkbox"/> <input type="checkbox"/> <input type="checkbox"/> <input type="checkbox"/>

5.2.2 Setting Zone Bell Output

Each zone on the 302-5880 may be selected to either sound or not sound the bells when in alarm. To set a zone to sound the bells set the DIP switch on bank SW1 to 'ON'. For example to set zone two (2) to sound the bells when in alarm set SW1-2 to 'ON'

5.2.3 Setting Zone Brigade Call Output

Each zone on the 302-5880 may be selected to either call or not call the brigade when in alarm. To set a zone to call the brigade set the DIP switch on bank SW2 to 'ON'. For example to set zone two (2) to call the brigade when in alarm set SW2- 2 to 'ON'.

5.2.4 Setting Zone Configuration

AVF on each zone on the 302-5880 may set to be either ON or OFF. To set a zone to have AVF set the DIP switch on bank SW3 to ON. For example to set zone 10, 12, 14, &16 to have AVF when in alarm set SW3- 2, 4, 6, & 8 to ON.

Zone AVF	SW3	Setting
Zone 9	1	Off
Zone 10	2	On
Zone 11	3	Off
Zone 12	4	On
Zone 13	5	Off
Zone 14	6	On
Zone 15	7	Off
Zone 16	8	On

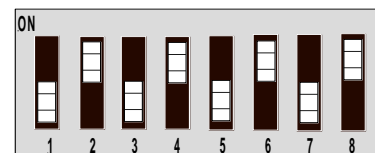

Switch 3 set to above example

6 SPECIFICATIONS

Size	450mmH x 400mmW x 130mmD (NZ 3200/16) 753mmH x 400mmW x 130mmD (NZ 3200/32)
Mains Supply	230V AC \pm 10% @ 0.5A
Power Supply Battery Charger	
Output Voltage	27V
Output Current (continuous)	1A
Output Current (peak)	1.8A
Quiescent Current Main Board	0.045A
Quiescent Current 8 Zone Board	0.053A
Bell Circuits	2 X 2A Circuits
Auxiliary Relay	Change Over Contacts 5A @ 30V
Detector Circuits	
Maximum Cable Loop Impedance	50 Ω

7 INSTALLATION AND INITIAL OPERATION

7.1 Unpacking And Inspection

Carefully check packing before unpacking goods for any transit damage. Unpack the goods and check both externally and internally for any loose or damaged components that may affect the appearance, installation or operation of the goods. An index of packaged goods is supplied loose.

7.2 Anti Static Precautions

To prevent damage to panel components please ensure that you are correctly earthed before touching or handling any of the wiring or printed circuit boards within the panel.

7.3 Installing the NZ3200

Do not apply power or connect batteries during this procedure.

1. Unpack the NZ3200 system.
2. Check for transit damage.
3. Unplug CN1 from the Main System Board and battery leads from TB1.
4. Unplug CN4 (and CN2 on F.S. panels)
5. Using a screwdriver undo four (4) slotted nuts holding the internal panel into the cabinet.
6. Withdraw the internal panel.
7. Drill all cable access and mounting holes.
8. Mount the unit into position.
9. Feed cables into the unit.
10. Install the engraved index with mounting provided.
11. Install the internal panel and secure with slotted nuts. Reconnect CN4 (and CN2 for Front Service panels.
12. Install any option cards and/or SGD.
13. Connect mains cabling to the mains switch. Ensure incoming Mains is properly earthed using stud provided.
14. Connect detector cabling.
15. Connect ancillary cabling.
16. Set DIP switches on the 302-7080 and 302-5880 as necessary.

7.4 Removing and Reinstalling the Index Panel

To remove the index panel with the panel installed and wired requires the following before the above procedure can be performed.

1. Turn off mains power to the unit at the distribution board.
2. Disconnect the batteries.
3. Disconnect mains cabling from the switch block.
4. Remove all cables on the 302-7080, and 302-5880 if fitted, noting the position of each cable before removal.
5. Reverse procedure once the index has been fitted.

7.5 Initial Operation

1. Switch on mains power to the unit.
2. The internal buzzer will sound for approx one second. Battery defect LED should be illuminated.
3. Connect batteries. Press 'RESET', Battery defect LED should extinguish.
4. The unit is ready for operation.

8 SYSTEM OPERATION

8.1 Resetting the System

To reset the system after a fire, press the 'RESET' button on the Main System Board. This will return the system back to its normal state if the cause of the alarm has been removed. The buzzer will sound for confirmation.

8.2 Isolating the Bells/Sounders

Bells may be isolated by either pressing the Bell Isolate switch on the Main System Board, or by operating the 'Silence Alarms' key switch on the outside of the cabinet.

Pressing Bell isolate on the Main System Board will cause the buzzer to beep and the LED above the switch to illuminate. To return Bells to normal press the switch again.

Note: Operating the key switch will cause a Defect signal to be sent.

8.3 Using the Walk Test Facility

To start the walk test facility, press the 'Test' switch on the Main System Board. The buzzer will beep once and the LED above the switch will illuminate. To avoid signalling the brigade isolate the Signal Generating Device (SGD). If it is not desirable to operate the sounders then isolate the bell as detailed above. Do not close the door at this stage.

The detectors can now be tested. As a detector is set into alarm the system will operate as normal, except that after approximately four seconds the detectors on the circuit in alarm will be reset. After testing is complete, press the 'Walk Test' switch to return to normal. Return any other switches to normal before closing the door of the NZ3200.

8.4 Self Test Facility

To start the test, press the 'Test' button twice. The system will now place each zone into fire and defect conditions sequentially. After each zone is tested, the system will flash the Defect and Fire LED of each zone that operated correctly.

The test will terminate when finished. It may also be terminated at any time by a another press of the 'Test' switch.

8.5 Evacuation

On the door of the NZ3200 a key switch is provided for Evacuation, operating this key switch will cause the system to operate the bells. This will override any other bell isolate or silence condition.

9 OPTIONS

9.1 ASPI Relay Board

9.1.1 Description

The ASPI (AMPAC Serial Peripheral Interface) Relay Board (302 5930) will provide the NZ3200 system with a 5 Amp relay contact for use by ancillary devices.

A fire zone or certain system functions can activate the relay. Refer to the table below.

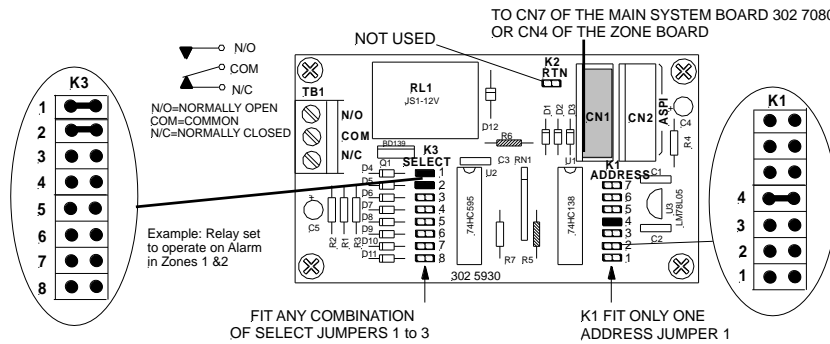

Figure 12: ASPI Relay Board Layout

9.1.2 Settings

Select K3	Address 4 K1	Address 2 * K1	Address 1 K1
1	Zone 1 alarm	Buzzer	Zone 1 defect
2	Zone 2 alarm	Bell #	Zone 2 defect
3	Zone 3 alarm	Defect	Zone 3 defect
4	Zone 4 alarm	Fire ! (selected zones)	Zone 4 defect
5	Zone 5 alarm	Fire (any zone)	Zone 5 defect
6	Zone 6 alarm	Normal	Zone 6 defect
7	Zone 7 alarm		Zone 7 defect
8	Zone 8 alarm	PSU shutdown	Zone 8 defect

Will not operate on Trial Evacuation

! Normally energized. Operates from zones with "FIRE" output selected

* 302-7080 only

9.1.3 Installing the ASPI Relay Board

1. Power system down and mount the board on standoffs at the bottom left side of the panel. Holes are already drilled to accept these.
2. To connect a single ASPI board to an 302-7080, plug one end of the eight-way cable provided into CN1 of the ASPI board and the other end into CN7 of the 302-7080. To add more than one ASPI board onto an 302-7080 connect CN1 of the second ASPI board to CN2 of the first, etc. A maximum of four ASPI boards is permitted per 302-7080. ASPI relay boards may also be connected to the 302-5880. Only four ASPI relay boards may be fitted to a single 302-5880.
3. On the ASPI board there are a number of options available. Link K1 sets the address of the board, only one address may be selected, only the 302-7080 board uses address 2. Link K3

sets the conditions that will activate the relay. Any combination is allowable. For example if the relay needs to activate from a fire on zone 1 or 2 then K1 would be set to 4 as Address 4 contains the zone alarm conditions and jumpers inserted in Select 1 and 2 as they are the link to the actual zones. See above.

Link K2 must be left open.

4. Turn system on and test relay functions.

9.2 8 Way Relay Board

9.2.1 Description

302-6623 provides 8 zoned outputs in the NZ3200 fire alarm system, using the AMPAC Serial Peripheral Interface (ASPI). Only one 302-6623 may be connected directly to each 302-5880 zone board. Voltage-free changeover contacts are provided, with a 2A rating. Fast Fit Product Code is 155-0003.

9.2.2 Connections

CN2 on the relay board connects to either CN4 (AUX DATA) on the zone board, or to the previous ASPI device, by means of an 8-way cable. To add more than one ASPI boards onto an 302-5880 connect ASPI IN of the second ASPI board to ASPI OUT of the first , etc. Fit the G0098 ASPI Line Termination Plug to ASPI OUT on the last board on the ASPI bus. A maximum of four ASPI boards is permitted per 302 5880 or 8 per 302-7080. No connection should be made to CN1 or CN3, though CN3 may be used to monitor the 24V supply to the relay board.

9.2.3 Technical Specifications

SIZE	175mm x 98mm
FUNCTION SWITCHES	4 x selectable zone output selection
POWER SUPPLY	Provided via 8 way ribbon , nominal 27VDC (20-28V @ 170ma) Local 5V provided by IC3
OUTPUTS	Alarm, Isolate, Battery fault, valve monitor relays change- over contacts rated at 2A Relay 1-4 (RL5,6,7 and 8) selectable change-over contacts rated at 2A Contacts normally voltage-free, nominal 27V supply available to be wired to relays to provide switched 27V.
COMMUNICATIONS	Type Synchronous serial CMOS level Speed- Up to 100Kbps

9.2.4 Communications

The 302-6620 connects to the main FACP via HCMOS level synchronous serial transmission. IC5 decodes the chip selects, and allows clock and data into shift register IC4 via tristate buffer IC2. IC3 drives the relay coils.

9.2.5 Interface Relays

ALARM RELAY (CN5)

The alarm relay provides volt-free changeover contacts, which operate when any zone goes into alarm, except for indicate-only or valve monitor zones.

Note: this relay also operates if alarm test is carried out on any zone (except for indicate-only or valve monitor zones).

ISOLATE RELAY (CN6)

The isolate relay provides volt-free changeover contacts, which operate when any zone, or the fault output, is isolated.

BATTERY FAULT RELAY (CN7)

The battery relay provides volt-free changeover contacts, which operate when the panel detects a battery fault.

VALVE MONITOR RELAY (CN8)

The valve monitor relay provides volt-free changeover contacts, which operate when any valve monitor zone goes into alarm.

Note: this relay also operates if alarm test is carried out on any valve monitor zone.

9.2.6 Link Settings

For correct operation with the NZ3200 the jumper on **LK1** must be set to position **7**

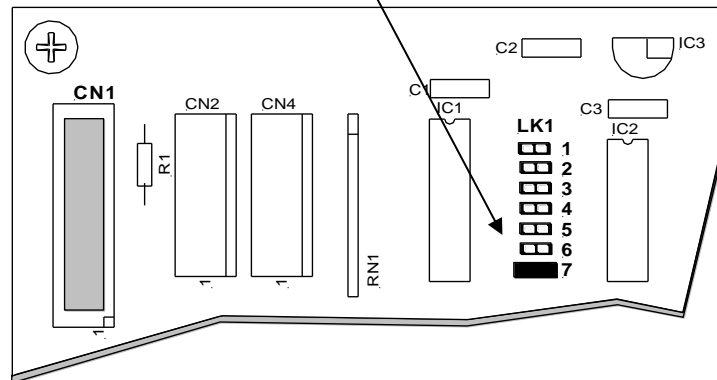

Figure 13: Link Settings

RELAY CONNECTIONS
Alarm Output

Normally open	Terminal block CN5 pin 1
Common	Terminal block CN5 pin 2
Normally closed	Terminal block CN5 pin 3

Battery Fault Output

Normally open	Terminal block CN7 pin 1
Common	Terminal block CN7 pin 2
Normally closed	Terminal block CN7 pin 3

Relay 1 Output

Normally open	Terminal block CN9 pin 1
Common	Terminal block CN9 pin 2
Normally closed	Terminal block CN9 pin 3

Relay 3 Output

Normally open	Terminal block CN11 pin 1
Common	Terminal block CN11 pin 2
Normally closed	Terminal block CN11 pin 3

Isolate Output

Normally open	Terminal block CN6 pin 1
Common	Terminal block CN6 pin 2
Normally closed	Terminal block CN6 pin 3

Valve Monitor Output

Normally open	Terminal block CN8 pin 1
Common	Terminal block CN8 pin 2
Normally closed	Terminal block CN8 pin 3

Relay 2 Output

Normally open	Terminal block CN10 pin 1
Common	Terminal block CN10 pin 2
Normally closed	Terminal block CN10 pin 3

Relay 4 Output

Normally open	Terminal block CN12 pin 1
Common	Terminal block CN12 pin 2
Normally closed	Terminal block CN12 pin 3

Note: 27V supply (may be wired to relay common connections to convert the outputs to switched positive outputs)

+27V	Terminal block CN3 pin 1
+0V	Terminal block CN3 pin 2

9.2.7 Programmable Relays

Each of the four programmable relays provides volt-free changeover contacts, which operate when one or more of the selected zones go into alarm.

Corresponding to each relay is a 4-pole DIP switch.

SW1 controls Relay 1 (CN9)

SW2 controls Relay 2 (CN10)

SW3 controls Relay 3 (CN11)

SW4 controls Relay 4 (CN12)

The 4 poles correspond to the 4 zones.

Pole 1 selects zone 1

Pole 2 selects zone 2

Pole 3 selects zone 3

Pole 4 selects zone 4

To select one or more zones to operate a particular relay, the required poles on the appropriate DIP switch are set to the ON position.

For example: If poles 1 and 3 of SW2 are set to the ON position, relay 2 will operate when zone 1 OR zone 3 go into alarm.

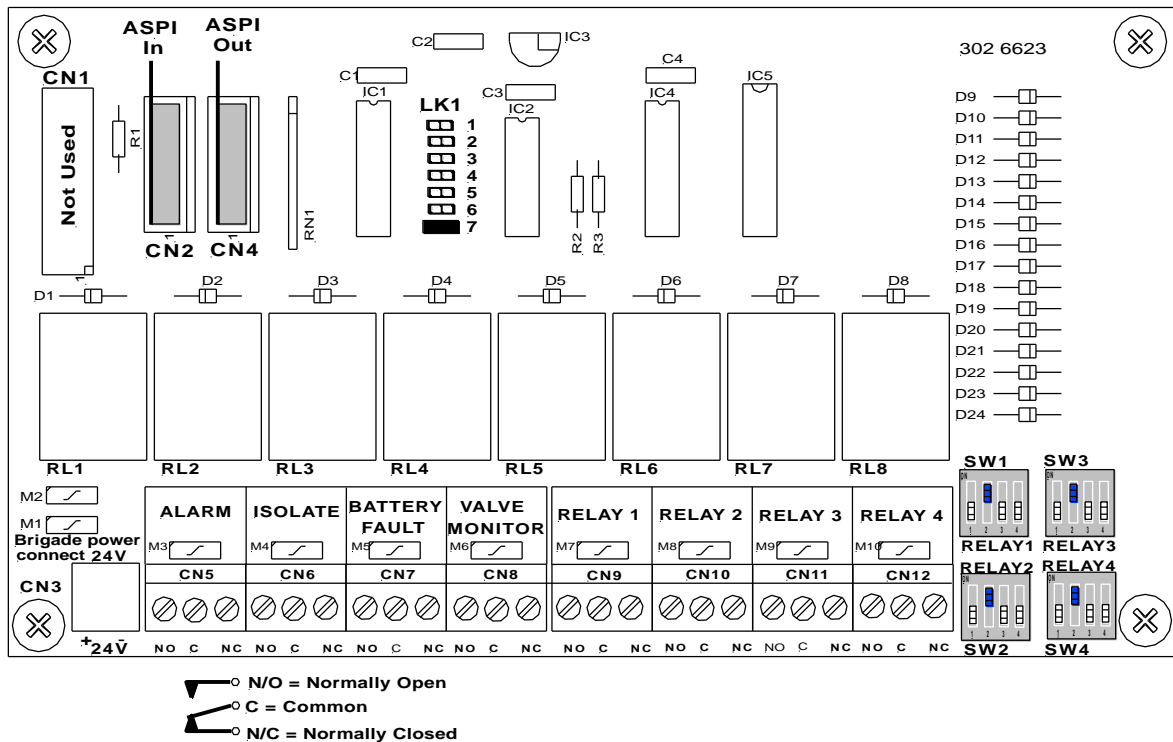

Figure 14: 8 Way Relay Board Layout

9.3 LED Mimic Driver Board

9.3.1 Description

The LED Mimic Driver Board (302-7150) in-conjunction with LED Mimic Display Board (302-7330) is designed to provide remote indication of the current status of an NZ3200 fire detection system. The mimic will indicate any zones in alarm as well as providing common fire, defect, DBA and system normal indications.

The LED Mimic Driver Board receives power and RS485 communications from the main panel. In small systems with 1, or 2 LED Mimic Driver Boards cabling can be achieved by using 2 Pair Twisted 100Ω Shielded Data Cable (0.2mm² cores minimum) eg OLEX JEC87F5002, BELDEN 9804, see Table 1 (on runs of less than 400 meters). In larger systems with more than two LED Mimic Driver Boards or long cable distances using 1 Pair Twisted 100Ω Shielded Data Cable eg OLEX JEC87F5001, BELDEN 9841 for communications it will be necessary to supply power to LED Mimic Driver Boards via separate cables. The size of the power cables will depend on the number of mimics used and the total distance.

Operation of the LED Mimic Driver Board is not monitored by the fire panel. If communications to the LED Mimic Board fail, the LED Mimic Board will flash the 'Defect' LED rapidly to indicate a communication defect. Correct operation of the LED Mimic Driver Board and fire panel is confirmed by the 'Normal' LED flashing on the LED Mimic Driver Board. The use of a LED Mimic Driver Board requires the installation of a Mimic Interface Board (302-6360) within the NZ3200 main panel.

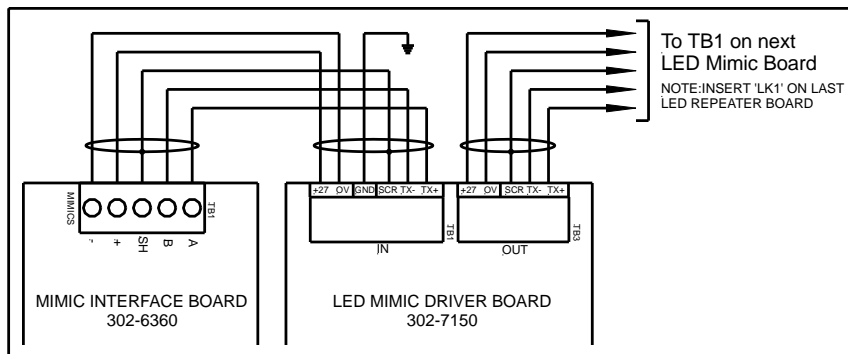

Figure 15: Cabling Using 2 Pair Data Cable

Recommended Maximum Cabling Distances using 2 Pair Data Cable.

Number of LED Mimic Boards	Maximum Distance
1	400m
2	200m

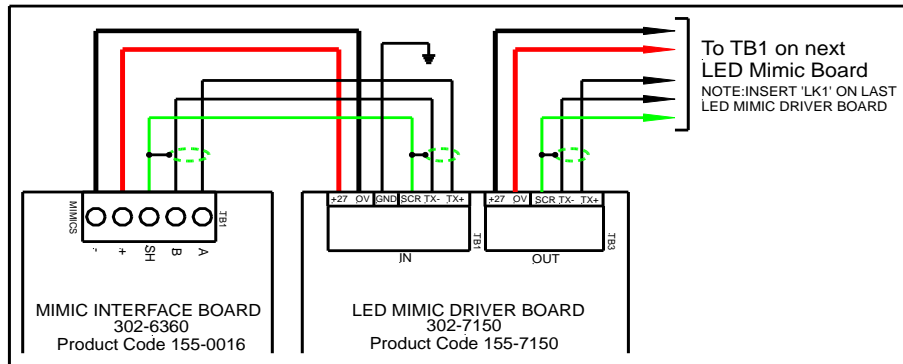

Figure 16: Cabling Using 1 Pair Shielded Cable and Separate Power Cable

Recommended Power Cable Size for Larger Systems.

Number of LED Repeater boards	Distance = <500m	Distance = 500m < >100m	Distance = 1000m < >1500m	Distance = 1500m < >2000m
1	0.3mm ²	0.5 mm ²	1 mm ²	1.5 mm ²
2	0.5 mm ²	1 mm ²	1.5 mm ²	2.5 mm ²
3	0.75 mm ²	1.5 mm ²	2.5 mm ²	4 mm ²

9.3.2 Specifications

DIMENSIONS: 197 mm (L) x 108 mm (W) x 25 mm (D)

POWER REQUIREMENTS: Voltage 27VDC
Current 100 mA (max)

FUNCTION KEYS

- Lamp test
- Lamp reset
- Buzzer mute
- CPU reset
- Address switches
- System switches

INDICATORS (LED) ON 302-7150

- Power on Green LED
- Normal Green LED
- Defect Yellow LED

POWER SUPPLY

- Provided via TB1, 20 to 28VDC @ 100 mA maximum
- 5volt output (aux power)

OUTPUTS

- 32 outputs for Zone indication CN1, CN2, CN3, CN4
- 4 outputs for Alarm, DBA, Defect and Normal indication CN5
- 1 buzzer output

9.3.3 Installation

To install the Mimic Interface Board & LED Mimic Driver Board.

1. Power system down.
2. Mount the Mimic Interface Board on standoffs at the bottom or left side of the panel. Holes are already drilled to accept these (same mounting hole size as Single ASPI Relay Board).
3. To connect a Mimic Interface Board to an 302-7080, plug one end of the first five-way cable provided into CN1 (Comms) of the Mimic Interface Board and the other end into CN8 (Mimic) of the 302 708, plug one end of the second five-way cable provided into CN2 (Power) of the Mimic Interface Board and the other end into CN3 of the 302-7080.
4. Mount the LED Repeater Board in target enclosure on stand-offs. Connect 302-7330 LED Mimic Board to 302-7150 LED Mimic Driver Board via cables provided. Connect communication, and power cables from 302-6360 Mimic Interface Board (In NZ3200 panel) to 302-7150 LED Mimic Driver Board.
5. Set Switches as follows SW2-1 OFF, SW2-2 OFF, SW2-3 ON, SW2-4 OFF, SW2-5 OFF, SW2-6 ON , SW2-7 OFF, and SW2-8 ON (All LED Repeater Boards are set to address No. 4).
6. Turn system on.

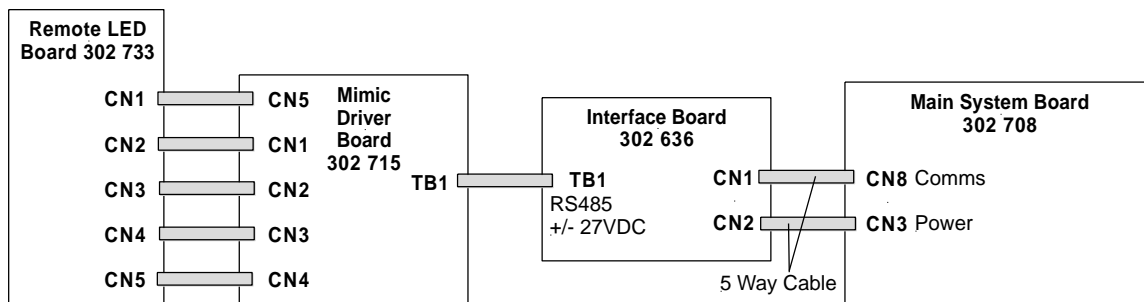
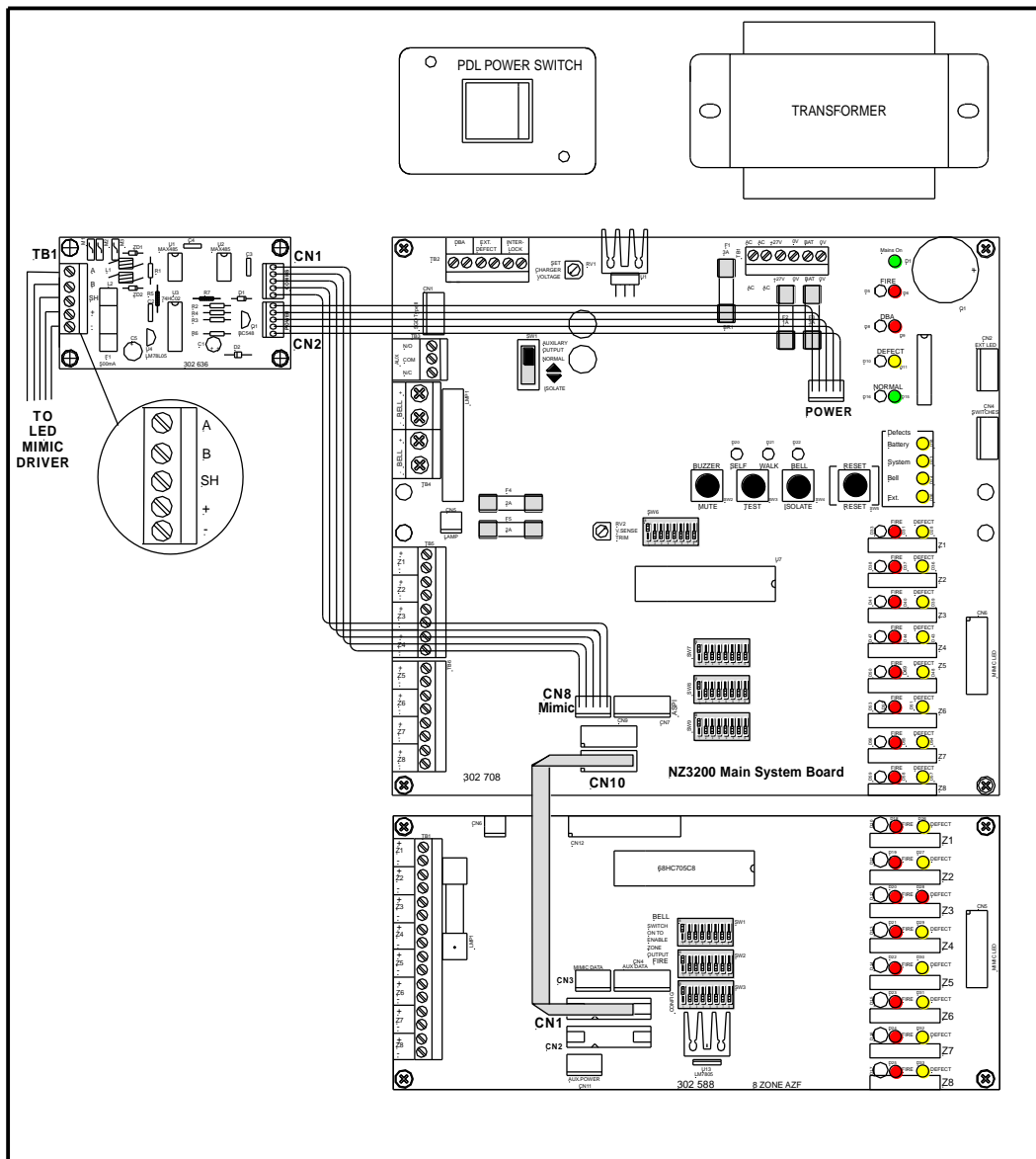

Figure 17: Main and Mimic Interface Board Cabling & Overall Block Diagram

9.3.4 Component Layout

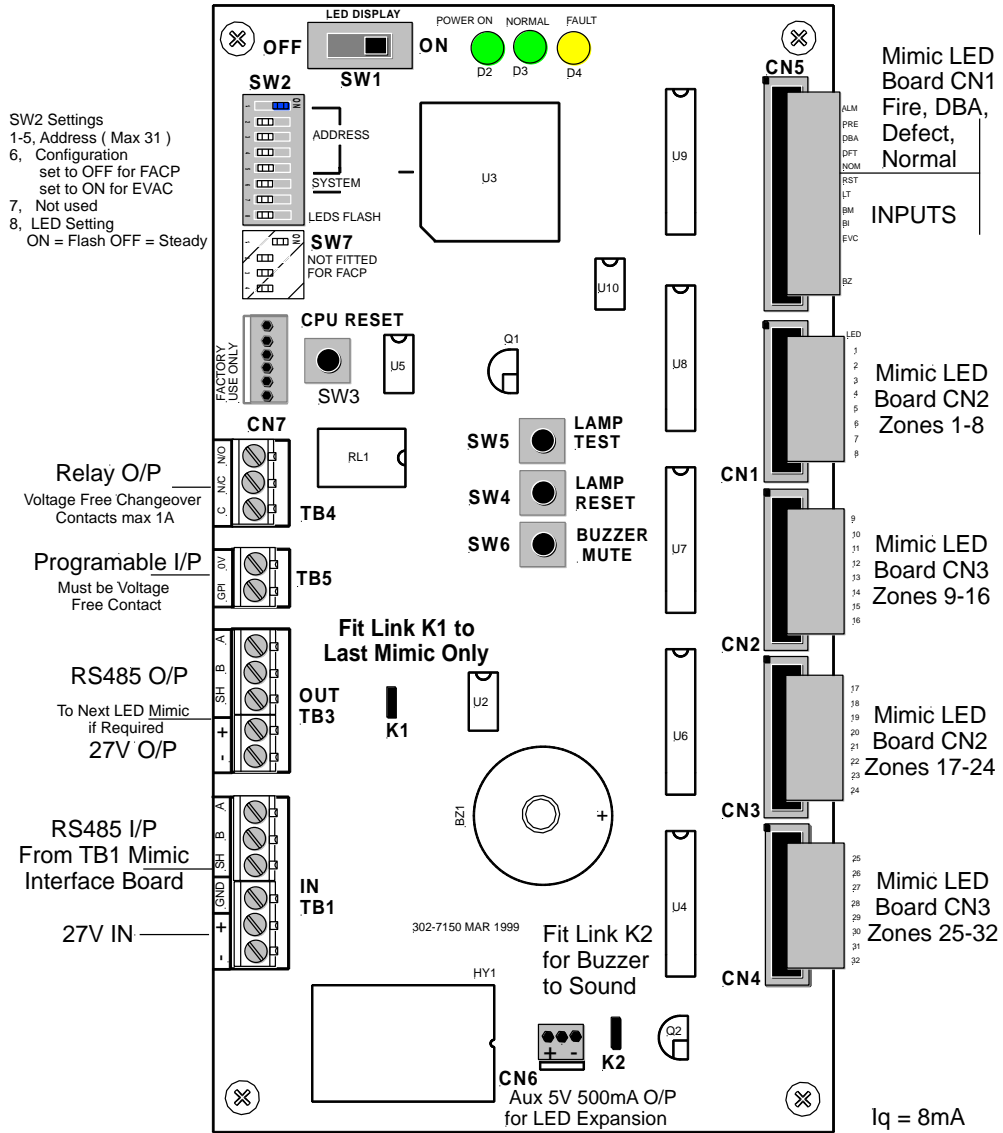

Figure 18: 302-7150 LED Mimic Driver Board

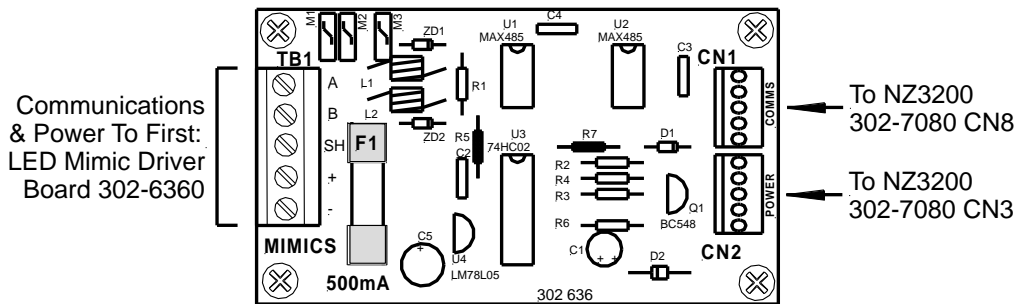

Figure 19: 302-6360 NZ3200 Mimic Interface Board

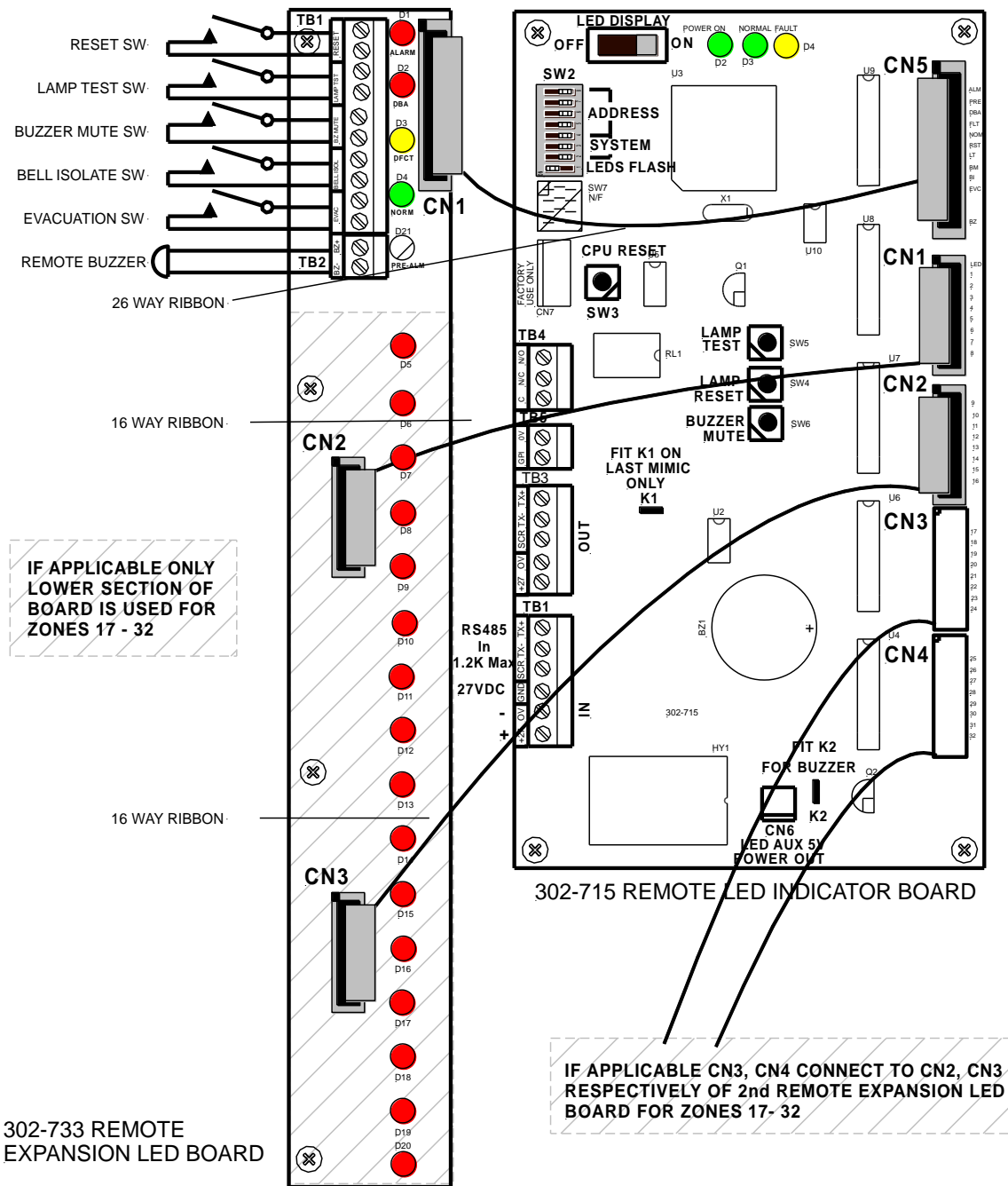

Figure 20: Cabling From the Remote LED Mimic Driver Board to the Remote Expansion LED Board

9.4 24 Volt Bell Driver Board

9.4.1 Description

The API-731(24V Bell Driver) allows a larger number of bells and sounders to be connected to the NZ3200 system than is normally possible.

This bell driver allows the NZ3200 system to monitor the bell lines as usual. This means a total of four bell drivers may be connected to an NZ3200 system whilst maintaining full monitoring. Larger numbers may be used if monitoring is not required.

Many variations are possible when connecting the bell drivers. The design of the bell driver retains the monitoring from the NZ3200 system, lines should be terminated as specified in the NZ3200 operators manual.

9.4.2 Features

The board provides a switched 27volt monitored output with a Defect output being returned to the NZ3200 for brigade indication.

9.4.3 Specifications

Size	:	84mm x 48mm
Power Requirements	:	27V DC @ 10mA

9.4.4 Connections

To install the bell driver board:

1. Disconnect mains power and batteries from the NZ3200 system.
2. Mount the bell driver using one of the option board locations.
3. Connect TB3 of the bell driver board to the Bell output of the NZ3200 302 708), +CTRL connects to Bell+, -CTRL connects to Bell-.
4. Connect TB3:+VE of the bell driver to the positive of the batteries (may be connected at the API-708, or from a previous bell driver), connect TB3: -VE to the negative of the batteries.
5. Terminate the bell line into the BELL (TB1: Bell+ and Bell-) output of the bell driver.
6. Terminate TB2:+VE,-VE of the BELL the bell line into the External Defect TB2:3,4 302 708) as shown.
7. Turn on the NZ3200 system. Check that the Defect LED on the bell driver board isn't illuminated.

In the example below the system is able to drive a 24V 2Amp bell line and three 24V 2 Amp bell lines. Because the current required by the bell driver from the 320 708 board is very low, it is permissible to supply the full two amps from each bell output of the 320 708.

In this instance each bell line would be terminated with a 5K resistor.

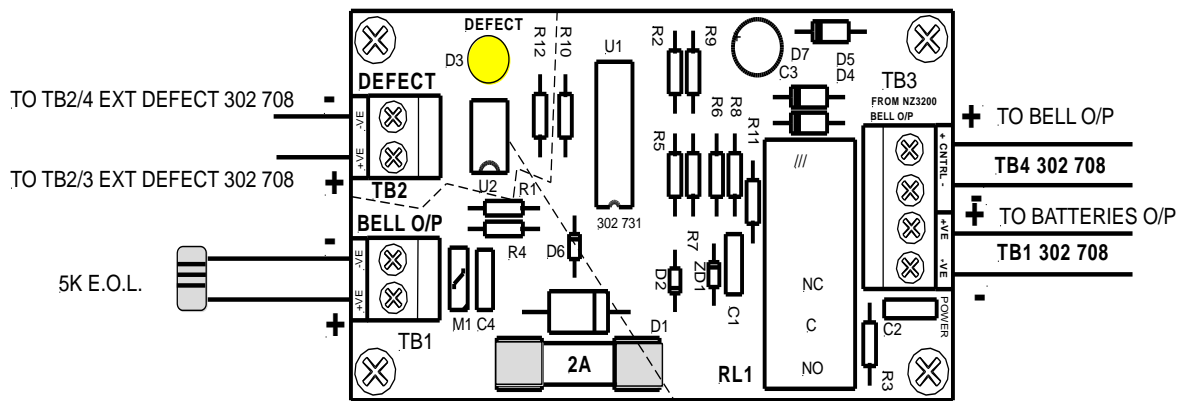

IF MULTIPLE BOARDS ARE USED CONNECT
DEFECT AS SHOWN BELOW

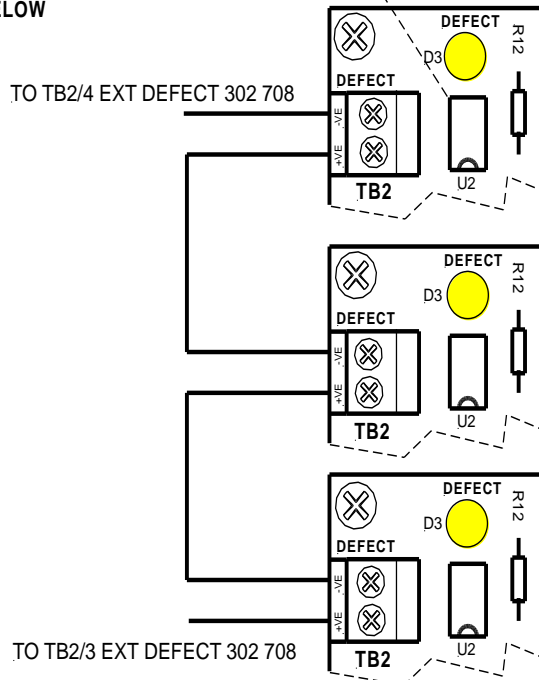

Figure 21: 24Volt Driver Board Layout and Wiring

10 TROUBLESHOOTING

Problem	Possible Cause/s	Suggested Remedy / Action
Mains LED is off	Mains supply is not operational. AC Fuse on MAF blown.	Check mains supply. Check and replace if necessary F1 on MAF.
Bell circuits in defect.	Diodes not fitted in series with bell. End of line not fitted. Fuses blown.	Fit diodes to bells as shown in section 4.2. Fit end of line resistor as stated in table 4.2 Check fuses F4 and F5 on MAF. Replace if necessary.
Zone always in defect.	Line is shorted. Line is open circuit.	Check and remove short. Locate and repair open circuit.
System defect LED flashes every 4 seconds.	Cable to CN4 of 302-7080 is disconnected.	Reconnect cable.
External defect operated but is not connected.	Wire link not fitted to external defect input.	Fit wire link.

11 INDEX PANEL ENGRAVING

The NZ3200 is supplied with a front index panel, which has been pre-drilled to accept all the LED's for the system. The NZ3200 can also be supplied as a rear service panel. The panel should be engraved as shown in the following illustrations. When the DBA facility is not required, the top two LED's indicate fire (see section 6 for DIP switch settings), where the DBA is used the top LED indicates fire and the second LED indicates DBA.

11.1 NZ3200/16 without DBA. For rear service FACP

In the example below the zone information, defect and normal have been engraved in 3mm high lettering and fire in 6mm high. Note that 'FIRE' should be situated between the two LED's for clarity.

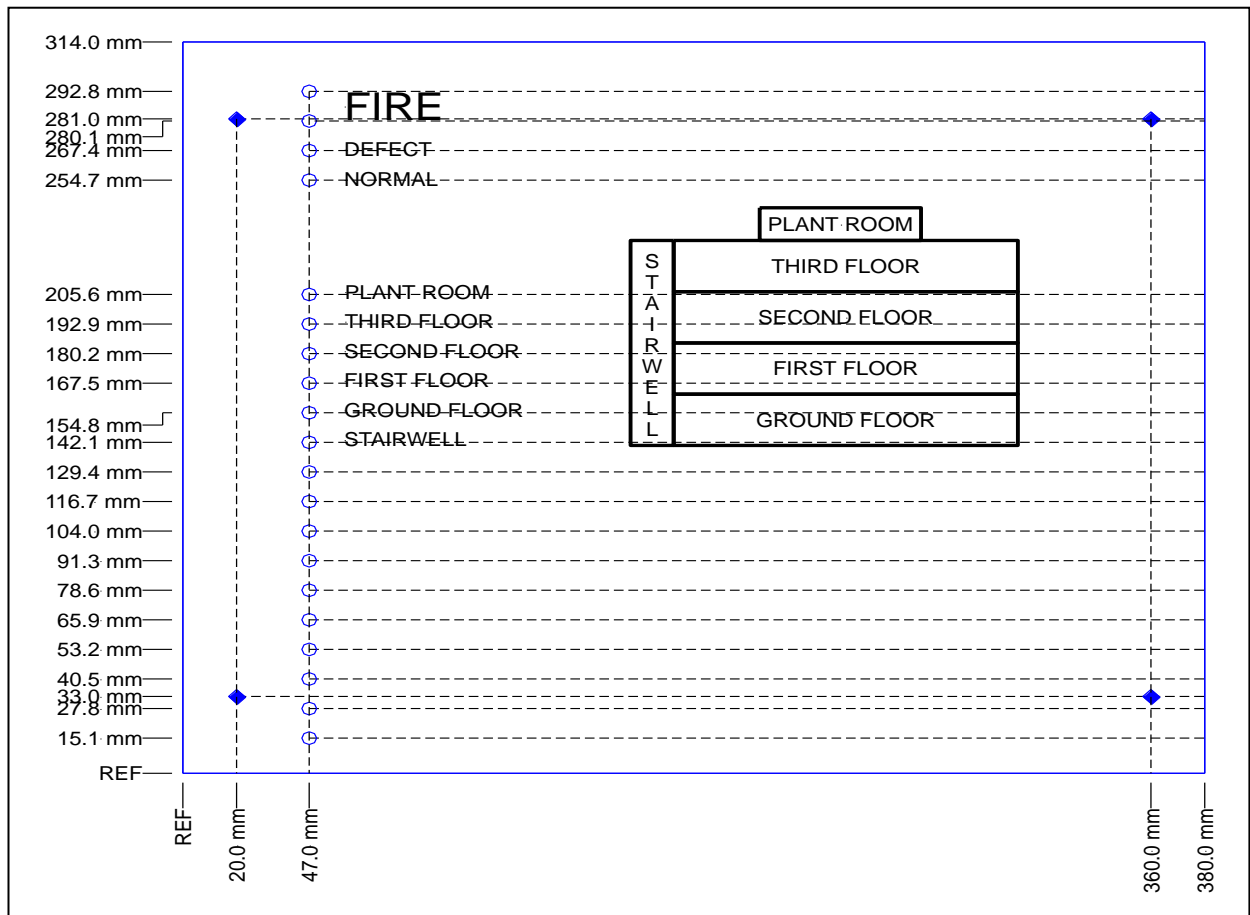

11.2 NZ3200/16 with DBA . For rear service FACP

In the example below all information is engraved in 3mm high lettering.

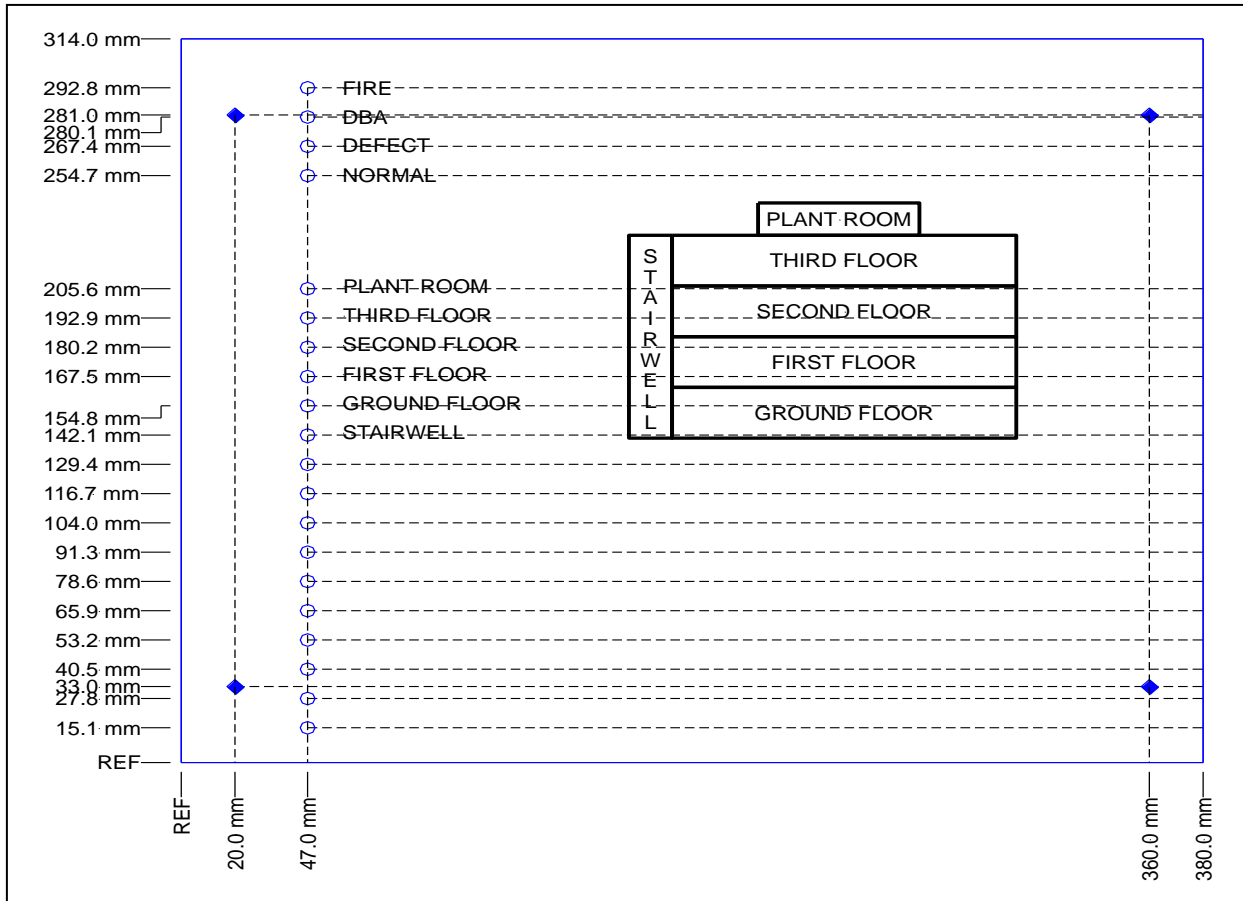

11.3 NZ3200/16 For front service FACP

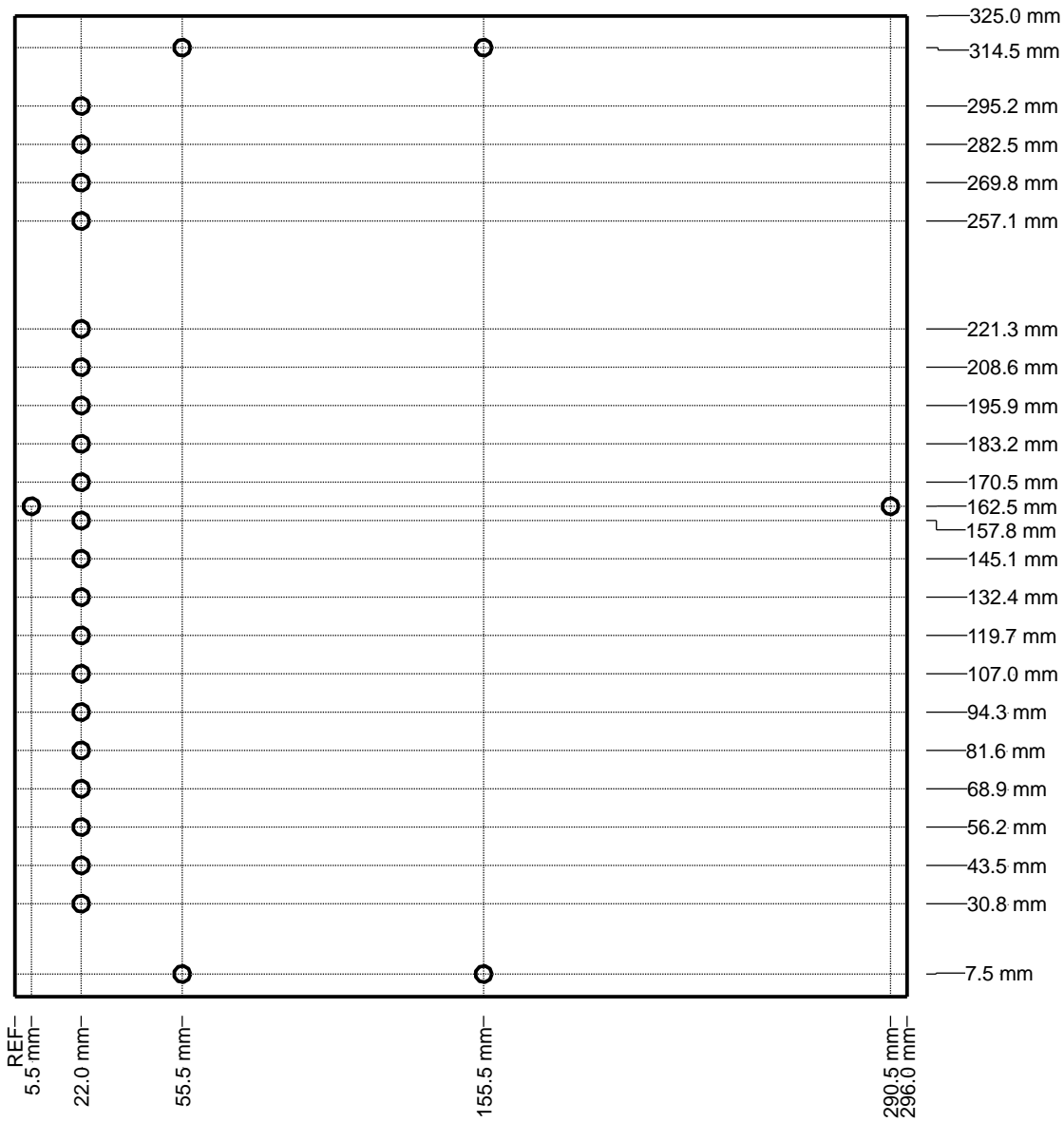

11.4 NZ3200/32 For Rear service FACP

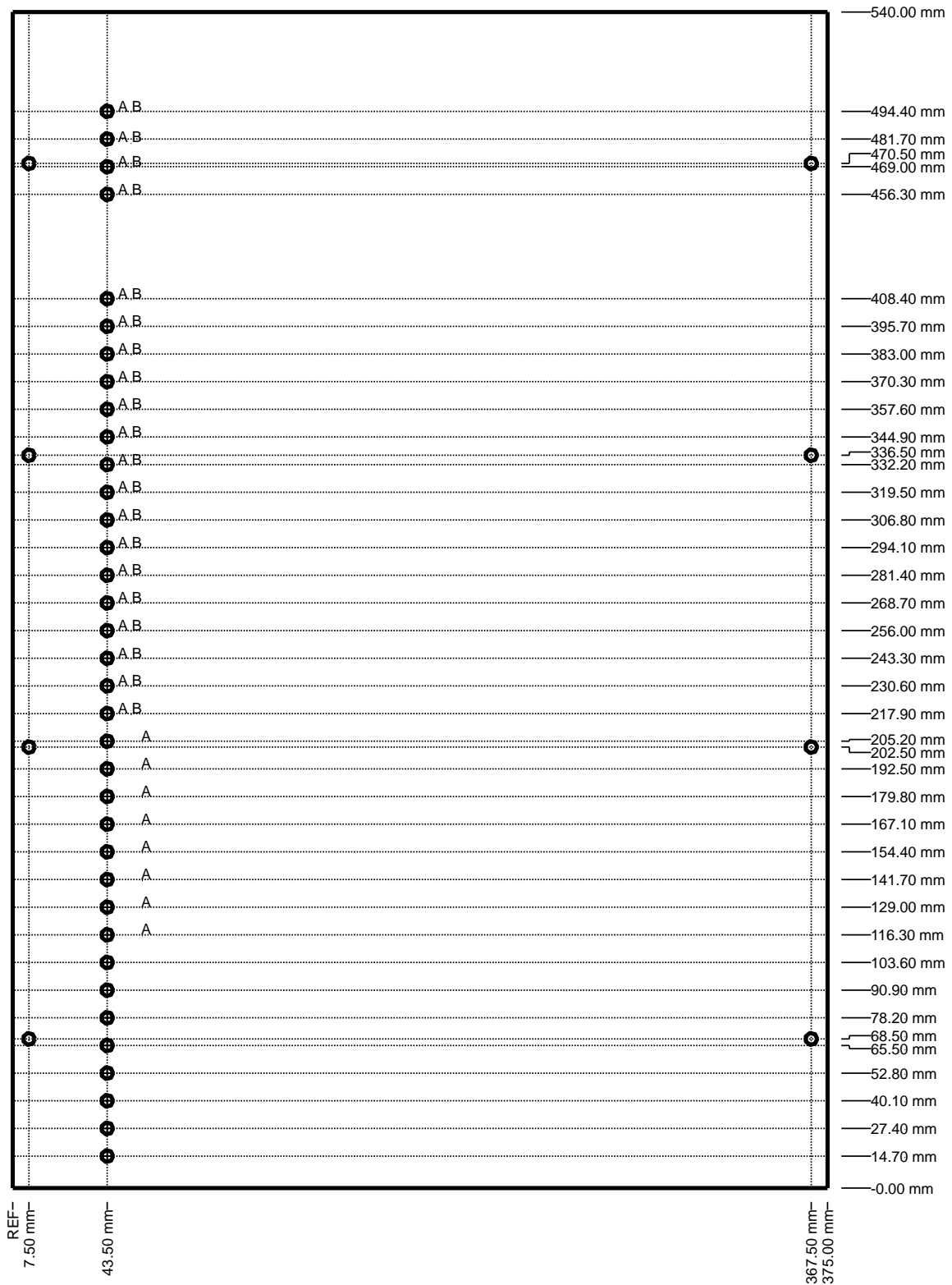

11.5 NZ3200/32 For Rear service FACP

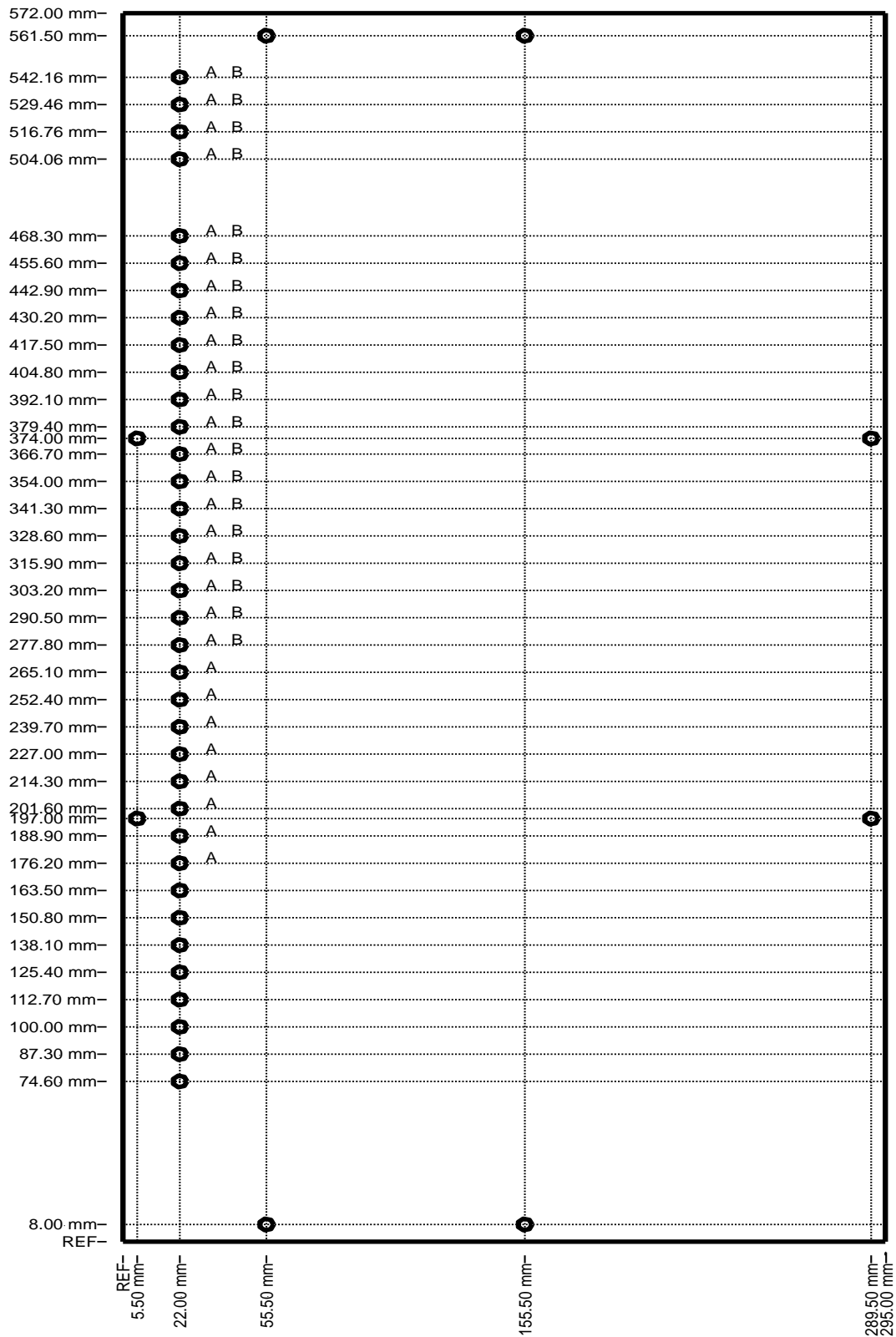

12 Appendix A. BATTERY CALCULATION.

Firstly, calculate system quiescent current

	Item	Quantity	Current each	Current mA
Control and Indicating Equipment	Main system board 302-7080		45mA	
	Zone Cards 302-5880		53mA	
	ASPI relays & or 8 Way Relay Board etc		6mA	
Detector circuits	Ampac Heat Detector blue Indicating 57°C		40µA	
	Ampac Heat Detector yellow Indicating 77°C		40µA	
	Apollo Series 65 Ionisation (LPC)		45µA	
	Apollo Series 65 Optical (LPC)		45µA	
	Apollo Series 65 Integrating Ionisation (LPC)		45µA	
	Apollo Orbis Optical		120µA	
	Apollo Orbis MultiSensor		120µA	
	Fireray 2000 Beam Detector Tx/Rx/controller		8mA	
	Ampac Manual Call Point		40µA	
Evac / Alert	EVAC50W24V		30mA	
Signalling	SGD Type II (302-6780)		2mA	
Ancillary load				
Total system quiescent current I _Q (mA)				

Secondly calculate maximum system alarm current

	Item	Quantity	Current each	Current
Control and Indicating Equipment	Quiescent current		-	
	Total zones used		26mA	
	MAF additional load		34mA	
	ASPI relays & or 8 Way Relay Board etc		20 mA	
Alarm Circuits	Bells		15mA	
	Evac / Alert		2.5A	
	Sounders		100mA	
Ancillary load				
Total alarm current I _A mA				

Minimum battery requirement is given by.

$$\text{BATTERY SIZE} = \frac{(24 \times I_Q) + (0.5 \times I_A)}{1000} = \frac{(24 \times \underline{\quad}) + (0.5 \times \underline{\quad})}{1000} = \quad \text{AH}$$

See appendix B for an example.

13 Appendix B. EXAMPLE BATTERY CALCULATION

Firstly calculate system quiescent current

	Item	Quantity	Current each	Current mA
Control and Indicating Equipment	Main system board 302-7080	1	45mA	45
	Zone Cards 302-5880	1	53mA	53
	ASPI relays & or 8 Way Relay Board etc	1	6mA	6
Detector circuits	Ampac Heat Detector blue Indicating 57°C	40	40µA	0.16
	Ampac Heat Detector yellow Indicating 77°C	0	40µA	0
	Apollo Series 65 Ionisation (LPC)	53	45µA	2.385
	Apollo Series 65 Optical (LPC)	0	45µA	0
	Apollo Series 65 Integrating Ionisation (LPC)	11	45µA	0.495
	Apollo Orbis Optical	0	120µA	0
	Apollo Orbis MultiSensor	0	120µA	0
	Fireray 2000 Beam Detector Tx/Rx/controller	0	8mA	0
	Ampac Manual Call Point	3	40µA	0.12
Evac / Alert	EVAC50W24V	0	30mA	0
Signalling	SGD Type II (302-6780)	1	2mA	2
Ancillary load		0		0
Total system quiescent current I _Q (mA)				109.16

Secondly calculate maximum system alarm current

	Item	Quantity	Current each	Current
Control and Indicating Equipment	Quiescent current	-	-	109.16
	Total zones used	16	26mA	416
	MAF additional load	0	34mA	34
	ASPI relays & or 8 Way Relay Board etc	1	20 mA	20
Alarm Circuits	Bells	40	30mA	1200
	Evac / Alert	0	2.5A	0
	Sounders	5	15mA	75
Ancillary load		0		0
Total alarm current I _A mA				1854.16

$$\text{BATTERY SIZE} = \frac{(24 \times 110) + (0.5 \times 1854)}{1000} = 3.567 \text{ AH}$$

Rounded = 3.6AH

Appendix C: DEVICES

Q I = Quiescent Current Draw

Heat Detectors

Order Code	Description	I _q
4255-0300	Ampac Heat Detector blue Indicating 57°C	40µA
4255-0400	Ampac Heat Detector yellow Indicating 77°C	40µA

Note: Rate of Rise Heat Detectors are also available.

Smoke Detectors

Order Code	Description	I _q
55000-217	Apollo Series 65 Ionisation (LPC)	45µA
55000-317	Apollo Series 65 Optical (LPC)	45µA
55000-220	Apollo Series 65 Integrating Ionisation (LPC)	45µA
45681-200	Apollo Series 60/65 universal base	N/A
201-0501	Apollo Orbis Optical	120µA
201-0505	Apollo Orbis MultiSensor	120µA
201-0528	Apollo Orbis universal base	N/A

Beam Detectors

Order Code	Description	I _q
220 0004	Fireray 2000 Beam Detector Tx/Rx/controller	8mA
220 0005	Fireray 50R Beam Detector	4mA
220 0006	Fireray 100R Beam Detector	4mA

Manual Call Points

Order Code	Description	I _q
213 0042	Ampac Manual Call Point	40µA

UNCONTROLLED DOCUMENT

NOTE: Due to Ampac's commitment to continuous improvement specifications may change without notice.