



Fire detection and evacuation solutions that save lives.



Discovery Product Guide

MAN3038-5

Contents

| | | |
|------|--|----|
| 1 | Introduction..... | 1 |
| 2 | Communications..... | 1 |
| 3 | Approvals..... | 2 |
| 4 | Discovery Feature-Smoke & Heat Detectors..... | 3 |
| 4.1 | Response Setting:..... | 3 |
| 4.2 | User bytes and other stored data:..... | 3 |
| 4.3 | Flashing LED:..... | 3 |
| 4.4 | Remote test feature:..... | 4 |
| 4.5 | Rejection of transient signals:..... | 4 |
| 4.6 | Interchangeability:..... | 4 |
| 5 | Discovery Features- Smoke Detectors..... | 6 |
| 5.1 | Drift compensation:..... | 6 |
| 6 | Optical Smoke Detector..... | 7 |
| 6.1 | Operating Principles:..... | 7 |
| 6.2 | Product Codes..... | 7 |
| 6.3 | Technical Data:..... | 8 |
| 7 | Optical/Heat Multisensor Detector..... | 9 |
| 7.1 | Operating Principles:..... | 9 |
| 7.2 | Product Codes..... | 10 |
| 7.3 | Technical Data:..... | 11 |
| 8 | Ionisation Smoke Detector..... | 12 |
| 8.1 | Operating Principles:..... | 12 |
| 8.2 | Product Codes..... | 13 |
| 8.3 | Technical Data:..... | 14 |
| 9 | Carbon Monoxide / Heat Multisensor Detector..... | 15 |
| 9.1 | Operating Principles..... | 15 |
| 9.2 | Product Codes..... | 16 |
| 9.3 | Technical Data:..... | 16 |
| 10 | Carbon Monoxide Detector..... | 17 |
| 10.1 | Operating Principles:..... | 17 |
| 10.2 | Product Codes..... | 19 |
| 10.3 | Technical Data:..... | 20 |
| 11 | Heat Detector..... | 21 |
| 11.1 | Operating Principles:..... | 21 |
| 11.2 | Product Codes..... | 22 |
| 11.3 | Technical Data:..... | 23 |
| 12 | Mounting Bases..... | 24 |
| 12.1 | Technical Description:..... | 24 |
| 13 | Manual Call Point..... | 25 |
| 13.1 | Operating Principles:..... | 25 |
| 13.2 | Non Standard Call Points:..... | 26 |
| 13.3 | Technical Data:..... | 27 |
| 14 | Interfaces..... | 28 |
| 15 | Isolators..... | 29 |
| 15.1 | Product Codes..... | 29 |
| 16 | Sounder Beacon Base..... | 30 |

| | | |
|----|--|----|
| 17 | Open Area Sounder Beacon | 32 |
| 18 | Maintenance of Detectors | 33 |
| 19 | Application of Discovery Detectors | 33 |
| 20 | Acknowledgement | 36 |

1 Introduction

Discovery® is a range of high-specification, analogue addressable fire detectors and alarm devices. Discovery detectors offer effective false alarm management by a combination of EN54 approved operating modes and sophisticated algorithms.

Drift compensation further reduces the likelihood of false alarms caused by a build-up of dust in the sensing chamber. In addition to the familiar smoke and heat detectors, the Discovery range features two multisensor detectors. One is an optical/heat multisensor which can be used to protect against many types of fire risk. The other is a carbon monoxide/heat multisensor which protects against both smouldering fires and those generating heat.

Key Features include:

- Five approved response modes for ease of optimisation to different environments
- Rejection of transient signals
- Drift compensation to ensure constant sensitivity
- 360° visibility in alarm
- Flashing LED option
- Alarm flag for fast alarm reporting
- Four bytes of non-volatile memory for user data
- Compatibility with XP95 systems

2 Communications

Discovery uses a digital communications protocol which has been developed from the XP95 protocol but which differs in that it allows communication in three different modes: Normal, Read and Write to allow a more extensive exchange of information and commands than previous analogue addressable ranges. In addition, Discovery can store data in non-volatile memory.

The Normal mode is identical to the XP95 protocol with the exception that the five additional analogue value bits in the XP95 protocol extension have been re-defined so that the control panel is able to distinguish between Discovery and XP95 devices.

The Read mode is used to check information stored in the non-volatile memory of each detector. It is accessed by using a simple extension to the Normal mode communication method from the control panel to the detector.

In Write mode the panel is able to write information to the detector by extending the communication method in the same way as in Read mode.

During Read or Write modes a detector can signal an alarm by means of the alarm flag and alarm address bits.

Discovery detectors are compatible with XP95. It should be noted, however, that Discovery features will not be available when Discovery is used with XP95 control panels. Panels with drift compensation algorithms should disable the algorithms when communicating with Discovery.

3 Approvals

The Discovery range of detectors and bases is approved by a large number of certification bodies. These include approvals to EN54:2001 including amendment A1:2002 and amendment A2 2006 with LPCB, AS1603 with Activfire, AS7240 with SAI Global as well as VdS, BOSEC and VNIPO. Discovery is also approved to both North American (UL, FM) and marine standards.

Discovery complies with the requirements of a number of European New Approach Directives such as the EMC Directive 89/336/EEC and the Construction Products Directive 89/106/EEC.

All Discovery products will comply with the marking requirements of the WEEE Directive, 2002/96/EC.

Australian Standards

Currently there are two standards in Australia for point type smoke detectors, the older AS1603.2 standard, and AS7240.7 – which has been adopted from the ISO7240.7 standard (this standard is heavily based on the European EN54.7 standard).

AS1603.2 requires the nominal sensitivity (S) of the detector to be between 0 and 15 %Obs/m, with the maximum sensitivity being greater than 0.5S or S-2 and a minimum sensitivity being less than 1.5S or S+2. The test method is specified in AS2362.17 – which states the smoke is produced by burning untempered hardboard (masonite) and the spread of the smoke is unassisted. In practise the smoke does not disperse evenly and tends to “clump” together, and therefore it is not uncommon to get a “spread” of obscuration levels.

AS7240.7 does NOT require the sensitivity of the detector to be within a set range. The detector is tested with 4 “test fires” (smouldering wood, smouldering cotton, flaming plastics and flaming heptane) – and the detector must go into alarm before the end of test condition. The end of test condition is an obscuration level (obscuration level is different for each “test fire” type). The obscuration threshold of the detector is determined (using an aerosol generated from pharmaceutical grade paraffin oil) to verify the repeatability, directional dependence and reproducibility of the detector meets the requirements of the standard. The test apparatus used to determine the sensitivity uses wind to assist the dispersion of the aerosol.

As the composition of the “smoke” between AS1603.2 and AS7240.7 is different and the test apparatus is different – the resulting threshold sensitivities between the two standards differ. Generally the sensitivities measured under AS1603.2 are higher (up to 5%Obs/m) than measured under AS7240.7. A reason for this is that the smoke spread under AS7240.7 is uniform – as it is wind assisted.

It should be noted that under AS7240.7 – the performance of the detector is determined by the response to the 4 test fires, NOT the threshold sensitivity level.

4 Discovery Feature-Smoke & Heat Detectors

4.1 Response Setting:

Each detector in the Discovery range can operate in one of five response modes, any of which can be selected from the control panel. Each mode corresponds to a unique response behaviour, which can be broadly related to sensitivity to fire. Whatever the type of detector, Mode 1 will give a higher sensitivity to fire than Mode 5. The selection of the most suitable mode depends on the application.

For ionisation and optical smoke detectors, the modes relate to different combinations of smoke response threshold and response time. For the heat detector, the mode relates to the fixed temperature setting and the sensitivity to rate-of-rise of temperature. For the optical/heat multisensor, the mode relates to the levels of smoke and heat sensitivity and to the way in which the responses of the two sensors are combined, although one mode is a 'smoke only' response and another is a 'heat only' response.

For the CO/Heat Multisensor the two outputs are also combined to provide one output, although one operating mode is CO only and one is heat only.

The response characteristics of the detectors have been carefully set so that detectors will comply with the requirements of the relevant part of EN54 in all response modes. The mathematical algorithms embedded in the detectors are used to carry out changes in characteristics between modes. Since the response characteristics are defined within the detectors, Apollo takes responsibility for compliance with standards in different response modes.

The internal signal processing of the detectors is designed so that the analogue value reported is always close to 25 for a normal condition. The alarm threshold is 55, irrespective of the response mode selected. Similarly, the alarm flag in the protocol is always set when the analogue value exceeds 55, irrespective of mode. This simplifies the switching between response modes since the alarm threshold in the control panel can remain fixed at 55 and the alarm flag is valid in all modes.

The response mode, which is selected through the protocol, is stored in non-volatile memory and will therefore be retained when the detector is powered down. All Discovery detectors are factory set to mode 3 before shipping. Response modes are defined more fully in the individual detector descriptions. It is, however, possible for the control panel to read the smoke and heat values of the optical/heat multisensor detector and the CO and heat values of the CO/ Heat Multisensor separately. This is a highly effective measure to reduce false alarms. The feature is control panel dependent and the panel manufacturer should be contacted for further details.

4.2 User bytes and other stored data:

All Discovery devices contain non-volatile memory, in the form of Electrically Erasable Programmable Read Only Memory (EEPROM), which is included primarily to store data needed for the correct operation of the device. However, four bytes of this EEPROM are available to the user and can be accessed by the control panel through the protocol. This block of non-volatile memory can be used, for example, to store the installation date, the site code or date of last service. The only restriction on use is that the maximum number of write cycles should not exceed 10,000 over the life of the device.

4.3 Flashing LED:

All Discovery detectors have two integral LED indicators, which can be illuminated at any time by the control panel to indicate devices in alarm. When activated, the LEDs will draw an extra 3.5mA from the loop. In addition to this mode of operation it is possible to enable a flashing LED mode by writing to one of the memory locations. In this mode the LEDs will flash each time the device is polled.

This facility is available on all Discovery detectors and the manual call point. Discovery detectors and call points are factory set to non flashing mode.

4.4 Remote test feature:

This feature, available on all Discovery detectors and the call points, is enabled from the control panel by changing the state of a forward command bit. On receipt of the command the detector is forced by electrical means into an alarm condition. After a delay of up to 20 seconds due to signal processing, an analogue value of 85 is returned, provided that the detector is functioning correctly. This value is sustained until the forward command bit is changed back to its original state, after which a period of 20 seconds is required for the detector to return to its normal analogue value.

The manual call point is different in that the receipt of the command bit will cause the call point to generate the interrupt sequence, followed by a sustained analogue value of 64. The call point resets when the forward command bit is changed back to its original state.

4.5 Rejection of transient signals:

All Discovery detector algorithms are designed to give low sensitivity to very rapid changes in the sensor output, since these are unlikely to be caused by real fire conditions. This is achieved by digital low-pass filtering of the sensor values which optimises the rejection of false alarm sources while maintaining the response to fire.

The filter parameters depend on the mode selected and for some modes the filtering is minimal. The filtering has no significant effect on the response to fires but does affect the way in which detectors respond to transients and to step changes of smoke or heat.

This is seen in the “minimum time to alarm” given in individual detector specifications. These times represent the time taken by the detector to reach the alarm condition when responding to a large step change in input.

4.6 Interchangeability:

Any Discovery detector may be replaced by any other type in the range. For example, if a smoke detector proved unsuitable in a particular application, it could be simply replaced with a heat detector set to the appropriate mode, provided that the maximum floor area coverage does not exceed that specified by BS5839: Part 1 or other local code.

Discovery detectors can also be used to replace XP95 detectors and again, it is possible to change types, e.g. smoke for heat or vice versa. Factory-new Discovery detectors are set to mid range, equivalent to XP95, and the flashing LED feature is disabled.

Notes

1. *The control panel must not have a drift compensation algorithm activated when interrogating Discovery detectors.*
2. *When replacing an XP95 detector with a Discovery detector ensure the control panel configuration is modified accordingly.*

Servicing Note

The “minimum time to alarm” referred to above is important when detectors are tested in situ, for example using aerosol test gas. A delay in response may be apparent.

Warning: all detectors are supplied with a red cover to protect against dust. The covers should be left in place until commissioning of the system when they should be removed. If, however, further building work is anticipated after commissioning, the covers should be replaced and alternative fire protection arrangements made. **When the system is handed over all covers should be removed.**

5 Discovery Features- Smoke Detectors

5.1 Drift compensation:

All Discovery smoke detectors include compensation for sensor drift as part of the internal signal processing

algorithm. The algorithm will compensate for changes in sensor output caused, for example, by dust in the chamber, and will therefore hold the sensitivity at a constant level even with severe chamber contamination. This increased stability is achieved without significantly affecting the detector's sensitivity to fire.

The compensation level is stored in the detector's memory as a single value between 0 and 31. The normal level, that is, with no compensation applied, is 16. Values above or below this indicate drift towards alarm or away from alarm respectively.

For compensation values in the range 4 to 30 the detector is working within its allowable range. A value which is less than 4 or greater than 30 results in a warning flag. A value of zero results in a fault signal.

The maximum compensation that can be applied is 31. If further drift occurs, the analogue values will simply track the drift and the detector will become more sensitive.

Compensation values are stored in non-volatile memory and will be retained even if detectors are disconnected. With few exceptions, it is possible to use the control panel to ascertain the level of compensation applied at any time.

For the Discovery smoke detectors, the compensation algorithms are designed such that the detectors meet the requirements of the European standard EN54-7:2000 in all response modes.

It is possible, through the protocol, to carry out a normalisation procedure which rapidly "updates" the drift compensation. This facility should only be used after a compensated detector has been cleaned and instant confirmation is required. (Otherwise the detector will automatically update itself within 24 hours).

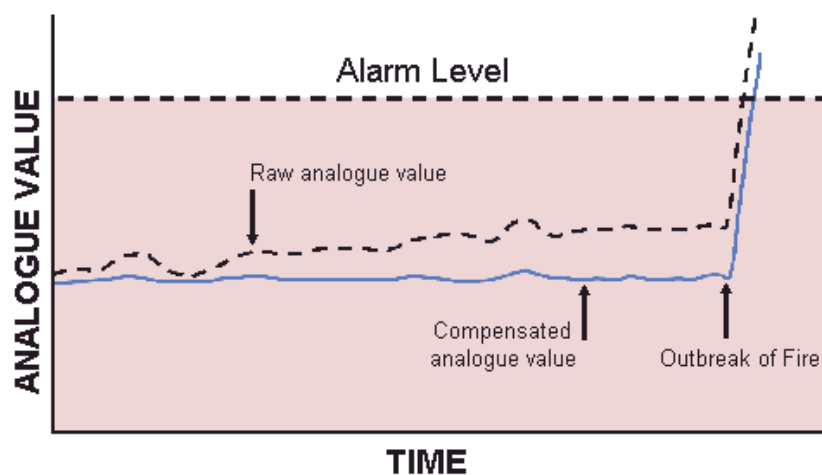

Figure 1 – Drift Compensation Graph

6 Optical Smoke Detector

6.1 Operating Principles:



The Discovery Optical Detector has a white moulded polycarbonate case with wind-resistant smoke inlets. The indicator LEDs are colourless when the detector is in quiescent state and red in alarm. Within the case is a printed circuit board which, on one side, has the light-proof chamber with integral gauze surrounding the optical measuring system and, on the other, the signal processing and communications electronics.

An infra-red light emitting diode within its collimator is arranged at an obtuse angle to the photo-diode. The photo-diode has an integral daylight-blocking filter. The IR LED emits a burst of collimated light every second. In clear air the photodiode receives no light directly from the IR LED, because of the angular arrangement and the chamber baffles. When smoke enters the chamber it scatters light from the emitter IR LED onto the photo-diode in an amount related to the smoke characteristics and density. The photodiode signal is processed to provide an analogue value for transmission when the detector is interrogated.

| Mode | Alarm threshold %/m | dB/m | Minimum time to alarm (sec) |
|------|---------------------|------|-----------------------------|
| 1 | 1.4 | 0.06 | 5 |
| 2 | 1.4 | 0.06 | 30 |
| 3 | 2.1 | 0.09 | 5 |
| 4 | 2.1 | 0.09 | 30 |
| 5 | 2.4 | 0.11 | 5 |

Table 1 – Optical Detector Operating Modes (rates comply with EN54-7: 2000)

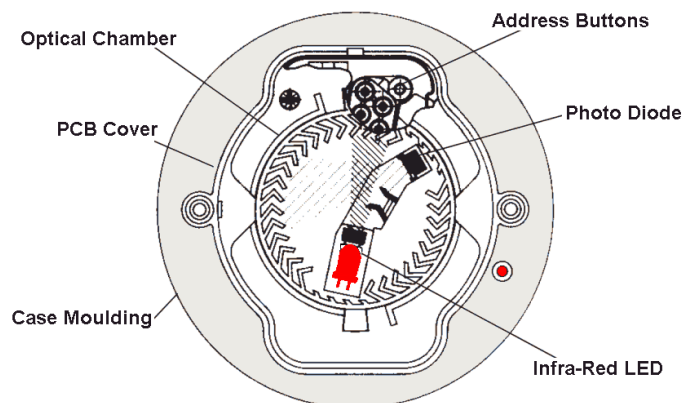

Figure 2 - Top Section - Discovery Optical Smoke Detector

6.2 Product Codes

| Product Description | EN54-7 | AS7240-7 |
|----------------------------------|--------------|-----------|
| Discovery Optical Smoke Detector | 58000-600AMP | 4106-2005 |

6.3 Technical Data:

Specifications are typical and given at 23°C and 50% relative humidity unless specified otherwise.

| | |
|--|--|
| Detector Type: | Point type smoke detector for fire detection and alarm systems for buildings |
| Detection Principle: | Photo-electric detection of light scattered in a forward direction by smoke particles |
| Chamber Configuration: | Horizontal optical bench housing an infra-red emitter and sensor arranged radially to detect forward scattered light |
| Sensor: | Silicon PIN photo-diode |
| Emitter: | GaAIAs Infra-red light emitting diode |
| Sampling Frequency: | 1 per second |
| Supply Wiring: | Two wire monitored supply, polarity insensitive |
| Terminal Functions: | L1 and L2: supply in and out connections +R remote indicator positive connection (internal 2.2KΩ resistance to positive) -R remote indicator negative connection (internal 2.2KΩ resistance to positive) |
| Supply Voltage: | 17 - 28V DC |
| Communication Protocol | Apollo Discovery 5-9V peak to peak |
| Ripple Voltage: | 2V peak to peak maximum at 0.1Hz to 100KHz |
| Quiescent Current: | 300μA at 24V DC |
| Power-up Surge Current: | 1mA |
| Maximum power up time: | 10s |
| Alarm Current, LED on: | 3.5mA |
| Remote output characteristics: | Connects positive line through 4.5KΩ (5mA maximum) |
| Clean-air analogue value: | 23 +4/-0 |
| Alarm level analogue value: | 55 |
| Alarm Indicator: | 2 colourless Light Emitting Diodes (LEDs); illuminating red in alarm. Optional remote LED |
| Temperature range: | -40°C to +70°C |
| Humidity: | 0% to 95% relative humidity (no condensation or icing) |
| Effect of Atmospheric Pressure: | None |
| Effect of Wind Speed: | None |
| Vibration, Impact & Shock | To EN54-7: 2000 |
| IP Rating: | 44 in accordance with BS EN 60529 |
| Dimensions: | Detector: 100mm Dia x 42mm H, Detector in Base: 100mm Dia x 50mm H |
| Weights: | Detector 105g, Detector in Base:160g |
| Material: | Detector housing: White polycarbonate rated V-0 in accordance with UL 94. Terminals: Nickel plated stainless steel |

7 Optical/Heat Multisensor Detector

7.1 Operating Principles:



The Discovery Multisensor construction is similar to that of the optical detector but uses a different lid and optical mouldings to accommodate the thermistor (heat sensor). The sectional view (Fig 3) shows the arrangement of the optical chamber and the thermistor.

The Discovery Optical/Heat multisensory detector contains an optical smoke sensor and a thermistor temperature sensor whose outputs are combined to give the final analogue value. The way in which the signals from the two sensors are combined depends on the response mode selected. The five modes provide response behaviour which incorporates pure heat detection, pure smoke detection and a combination of both. The multisensor is therefore useful over the widest range of applications.

The signals from the optical smoke sensing element and the temperature sensor are independent, and represent the smoke level and the air temperature respectively in the vicinity of the detector. The detector's micro-controller processes the two signals according to the mode selected. When the detector is operating as a multisensor (i.e. modes 1, 3 and 4) the temperature signal processing extracts only rate-of-rise information for combination with the optical signal. In these modes the detector will not respond to a slow temperature increase – even if the temperature reaches a high level. A large sudden change in temperature can, however, cause an alarm without the presence of smoke, if sustained for 20 seconds.

Additional heat sensor information

Discovery optical/heat multisensor detectors manufactured from mid 2009 incorporate additional temperature information that is intended for use in signal processing. Temperature data can be read separately by the control panel (see Note 1) and used to validate an alarm signalled by the multisensor analogue value. An example of this would be a high multisensor analogue value not accompanied by an increase in heat: this would indicate that an agent other than smoke, e.g. steam, had caused the high analogue value.

The exact method of polling to make use of this feature is described in a Technical Sales document available to panel partners. This feature offers protection from false alarms.

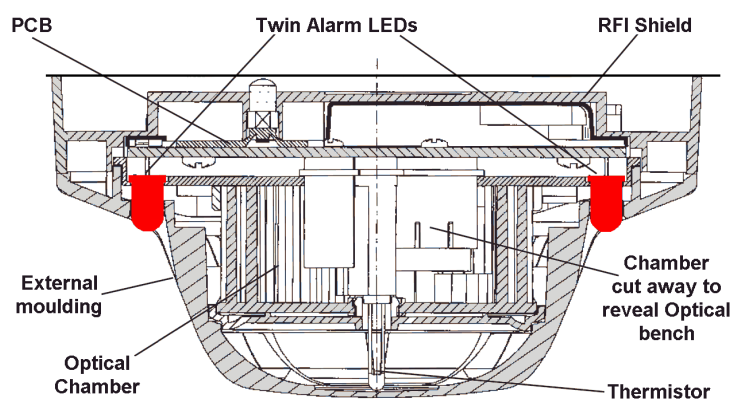

Figure 3 – Sectional View – Discovery Multisensor Detector

| Mode | Smoke Sensitivity (grey smoke) %/m dB/m | Temperature Sensitivity | Response Type | Minimum Time to Alarm (seconds) |
|------|---|----------------------------|------------------|---------------------------------------|
| 1 | 1.1 0.05 | >15°C Increase | Multisensor | 20 |
| 2 | 2.1 0.09 | Not set to heat response | Optical | 30 |
| 3 | 2.8 0.12 | >21°C Increase | Multisensor | 20 |
| 4 | 4.2 0.19 | >15°C Increase | Multisensor | 20 |
| 5 | No response to smoke | Refer Mode 5 below | Heat A1R | 15 |

Table 2 – Multisensor Detector Operating Modes

Characteristics of the response modes

The processing algorithms in modes 1 to 4 incorporate drift compensation.

The characteristics of the five response modes are summarised below.

Mode 1 has very high smoke sensitivity combined with high heat sensitivity. This gives a high overall sensitivity to both smouldering and flaming fires.

Mode 2 has a smoke sensitivity similar to that of a normal optical smoke detector. This mode is therefore equivalent to a standard optical detector. It is suitable for applications in which wide temperature changes occur under normal conditions.

Mode 3 has moderate smoke sensitivity combined with a moderate sensitivity to heat. This combination is considered the optimum for most general applications since it offers good response to both smouldering and flaming fires.

Mode 4 has lower than normal smoke sensitivity combined with high heat sensitivity. This makes it suitable for applications in which a certain amount of fumes or smoke is considered normal.

Mode 5 has no smoke sensitivity at all, but gives a pure heat detector response meeting the response time requirements for a Class A1R detector in the European standard EN54–5:2000. In this mode the detector will respond to slowly changing temperatures and has a “fixed temperature” alarm threshold at 58°C. The analogue value in this mode will give the approximate air temperature over the range 15°C to 55°C.

In mode 5, the smoke sensor is still active though it does not contribute to the analogue signal. As a consequence, if the detector is used in a dirty or smoky environment the optical sensor drift flag may be activated in the heat-only mode.

Notes

- *This applies only to panels which have been programmed to read the additional information.*
- *In situ testing of the Multisensor detector should be carried out as for smoke detectors in response mode 2 and for heat detectors in response mode 5. Both optical and heat sensors must be tested in modes 1,3 and 4.*
- *If the Multisensor is to be used in mode 5, heat detector spacing/coverage should be applied.*

7.2 Product Codes

| Product Description | EN54-5 & 7 (CEA4021) | AS7240-15 | AS1603-1 & 2 |
|--------------------------------|----------------------|-----------|----------------------|
| Discovery Multisensor Detector | 58000-700AMP | 4106-2008 | 201-0094 (58000-730) |

7.3 Technical Data:

Specifications are typical and given at 23°C and 50% relative humidity unless specified otherwise.

| | |
|--|--|
| Detector Type: | Point type heat detector for fire detection and alarm systems for buildings |
| Detection Principle: | Smoke: Photo-electric detection of light scattered in a forward direction by smoke particles Heat: Temperature dependant resistance |
| Chamber Configuration: | Horizontal optical bench housing an infra-red emitter and sensor arranged radially to detect forward scattered light |
| Supply Wiring: | Two wire monitored supply, polarity insensitive |
| Terminal Functions: | L1 and L2: supply in and out connections +R remote indicator positive connection (internal 2.2KΩ resistance to positive) -R remote indicator negative connection (internal 2.2KΩ resistance to positive) |
| Supply Voltage: | 17 - 28V DC |
| Communication Protocol | Apollo Discovery 5-9V peak to peak |
| Quiescent Current: | 400μA at 24V DC |
| Power-up Surge Current: | 1mA |
| Maximum power up time: | 10s |
| Alarm Current, LED on: | 3.5mA |
| Remote output characteristics: | Connects positive line through 4.5KΩ (5mA maximum) |
| Clean-air analogue value: | 23 +4/-0 |
| Alarm level analogue value: | 55 |
| Alarm Indicator: | 2 colourless Light Emitting Diodes (LEDs); illuminating red in alarm. Optional remote LED |
| Temperature range: | -40°C to +70°C |
| Humidity: | 0% to 95% relative humidity (no condensation or icing) |
| Effect of Atmospheric Pressure: | None |
| Effect of Wind Speed: | None |
| Vibration, Impact & Shock | To EN54-7: 2000 and EN54-5: 2000 |
| IP Rating: | 44 in accordance with BS EN 60529 |
| Dimensions: | Detector: 100mm Dia x 50mm H, Detector in Base: 100mm Dia x 58mm H |
| Weights: | Detector 105g, Detector in Base:160g |
| Material: | Detector housing: White polycarbonate rated V-0 in accordance with UL 94. Terminals: Nickel plated stainless steel |
| Smoke element only: | |
| Chamber confirmation: | Horizontal optical bench housing infra –red emitter and sensor, arranged radially to light detect forward scattered |
| Sensor: | Silicon PIN photo diode |
| Emitter: | GaAIAs infra red light emitting diode |
| Sampling frequency: | 1 per second |

8 Ionisation Smoke Detector

8.1 Operating Principles:



The Discovery Ionisation Smoke Detector uses the same outer case as the optical smoke detector and is distinguished by the red indicator LEDs. Inside the case is a printed circuit board which has the ionisation chamber mounted on one side and the signal processing and communications electronics on the other.

The ionisation chamber consists of a reference chamber contained inside a smoke chamber (Fig. 4). The outer smoke chamber has inlet apertures fitted with insect resistant mesh.

At the junction between reference and smoke chambers, the sensing electrode converts variations in chamber current into voltage changes.

When smoke particles enter the ionisation chamber, ions become attached to them with the result that the current flowing through the chamber decreases. This effect is greater in the smoke chamber than in the reference chamber, and the imbalance causes the sensing electrode to become more positive.

The analogue voltage at the sensor electrode is converted to a digital format which is processed to provide an analogue value for transmission to the control panel when the device is polled.

The Discovery Ionisation Detector, like all ionisation detectors, has some sensitivity to air movement (wind). The extent to which the analogue value will change depends on the wind speed and on the orientation of the detector relative to the wind direction. Relatively small changes in wind direction can cause significant changes in analogue value.

For wind speeds up to 1m/s (200ft/min) the change in analogue value will not exceed 5 counts. Continuous operation in wind speeds greater than 2m/s (400ft/min) is not recommended. However, wind speeds up to 10m/s (2000ft/min) can be tolerated for short periods and will not under any conditions increase the probability of false alarms.

Ionisation smoke detectors are supplied in individual packing with a red lid serving as a dust cover which can be left in place after fitting to prevent ingress of dust and dirt until commissioning of the system takes place. *At this point the covers must be removed.*

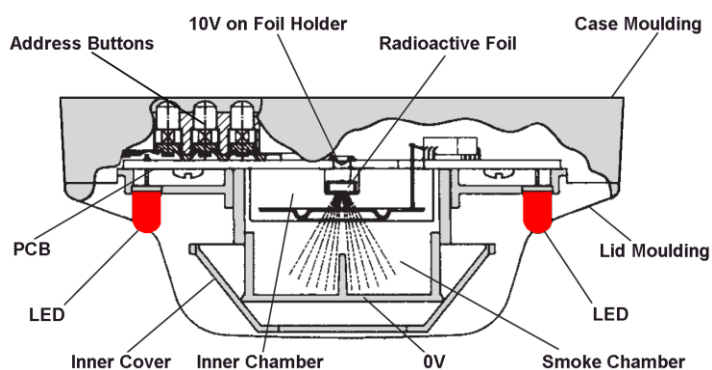

Figure 4 – Sectional View – Discovery Ionisation Smoke Chamber

| Mode | Alarm Threshold γ value | Minimum time to alarm (sec) |
|------|--------------------------------|-----------------------------|
| 1 | 0.45 | 5 |
| 2 | 0.45 | 30 |
| 3 | 0.70 | 5 |
| 4 | 0.70 | 30 |
| 5 | 1.0 | 5 |

Table 3 – Ionisation Detector Operating Modes (rates comply with EN54-7: 2000)

8.2 Product Codes

| Product Description | EN54-7 | AS7240-7 |
|----------------------|--------------|-----------|
| Discovery Ionisation | 58000-500AMP | 4106-2006 |

Safety Note

In the United Kingdom, ionisation smoke detectors are subject to the requirements of the Radioactive Substances Act 1993 and to the Ionising Radiations Regulations 1999 made under the provisions of the Health and Safety at Work Act 1974.

The detectors, independently tested by the Health Protection Agency (HPA), conform to all the requirements specified in the ‘Recommendations for ionisation smoke detectors in implementation of radiation standards’ published by the Nuclear Energy Agency of the Organisation for Economic Co-operation and Development (OECD) 1977.

There is no limit to the number of ionisation smoke detectors which may be installed in any fire protection system. Storage regulations depend on local standards and legislation, but, in the UK, up to 500 detectors may be stored in any premises, although there are stipulations on storage facilities if more than 100 ionisation detectors are stored in one building.

At the end of their recommended working life of ten years, ionisation smoke detectors should be returned to the manufacturer for safe disposal.

Guidance on storage and handling details can be requested from:

Radioactive Substances Regulation Function
 Environment Agency
 Rio House, Waterside Drive
 Aztec West, Almondsbury
 Bristol BS32 4UD.

Outside the UK, please contact the relevant national agency.

8.3 Technical Data:

Specifications are typical and given at 23°C and 50% relative humidity unless specified otherwise.

| | |
|--|--|
| Detector Type: | Point type smoke detector for fire detection and alarm systems for buildings |
| Detection Principle: | Ionisation Chamber |
| Chamber Configuration: | Twin compensating chambers using one single sided ionising radiation source |
| Radioactive isotope: | Americium 241 |
| Activity: | 33.3 kBq, 0.9µCi |
| Supply Wiring: | Two wire monitored supply, polarity insensitive |
| Terminal Functions: | L1 and L2: supply in and out connections +R remote indicator positive connection (internal 2.2KΩ resistance to positive) -R remote indicator negative connection (internal 2.2KΩ resistance to positive) |
| Supply Voltage: | 17 - 28V DC |
| Communication Protocol | Apollo Discovery 5-9V peak to peak |
| Quiescent Current: | 300µA at 24V DC |
| Power-up Surge Current: | 1mA |
| Maximum power up time: | 10s |
| Alarm Current, LED on: | 3.5mA |
| Remote output characteristics: | Connects positive line through 4.5KΩ (5mA maximum) |
| Clean-air analogue value: | 23 +4/-0 |
| Alarm level analogue value: | 55 |
| Alarm Indicator: | 2 Light Emitting Diodes (LEDs); illuminating red in alarm. Optional remote LED |
| Temperature range: | -30°C to +70°C |
| Humidity: | 0% to 95% relative humidity (no condensation or icing) |
| Effect of Temperature: | Less than 10% change in sensitivity over rated range |
| Effect of Atmospheric Pressure: | Operating: Suitable for installation up to 2,000m above sea level. |
| Effect of Wind Speed: | Less than 20% change in sensitivity at speeds up to 10m/s Note: slow changes in ambient conditions will automatically be compensated and will not affect sensitivity. |
| Vibration, Impact & Shock | To EN54-7: 2000 |
| IP Rating: | 44 in accordance with BS EN 60529 |
| Dimensions: | Detector: 100mm Dia x 42mm H, Detector in Base: 100mm Dia x 50mm H |
| Weights: | Detector 105g, Detector in Base:160g |
| Material: | Detector housing: White polycarbonate rated V-0 in accordance with UL 94. Terminals: Nickel plated stainless steel |

9 Carbon Monoxide / Heat Multisensor Detector

9.1 Operating Principles



The Discovery CO/Heat Multisensor Detector contains a CO detection cell and a thermistor temperature sensor whose outputs are combined to give the final analogue value. The way in which the signals from the two sensors are combined depends on the response mode selected. The CO/ Heat Multisensor detects the presence of carbon monoxide or heat or a combination of both.

The Multisensor construction is similar to that of a CO detector but uses a different lid in order to expose the thermistor to the surrounding air.

The signals from the CO sensing cell and the thermistor are independent and represent the amount of CO or the temperature present in the vicinity of the detector. When the detector is used in heat only mode (Mode 5) it operates as an A1R rate-of-rise heat detector with a static threshold of 58°C. Discovery CO/Heat Multisensor detectors incorporate additional temperature information that is intended for use in signal processing which is achieved in the same way as that of the Optical/Heat Multisensor.

Characteristics of Response Modes

Mode 1 has very high sensitivity to carbon monoxide combined with moderate sensitivity to heat. This gives a high overall sensitivity to both smouldering and flaming fires.

Mode 2 is set to report the presence of carbon monoxide only.

Mode 3 has moderate sensitivity to carbon monoxide combined with moderate sensitivity to heat and is used for general applications.

Mode 4 has lower than normal carbon monoxide sensitivity combined with moderate heat sensitivity making it suitable to areas where a certain amount of carbon monoxide might be considered normal.

Mode 5 has no response at all to carbon monoxide and acts as a rate-of-rise heat detector.

Notes

1. If the Multisensor is to be used in mode 5 heat detector spacing & coverage should be applied. Observe the recommendations of BS5839: Part 1 or other applicable code.
2. In situ testing of the multisensory detector should be carried out as for CO detectors in response mode 2 and for heat detectors in response mode 5. Both CO and heat sensors must be tested in modes 1, 3 and 4.

| Mode | CO Sensitivity (ppm) | Temperature Sensitivity (relative) | Response Type | Minimum time to alarm (seconds) |
|------|----------------------|------------------------------------|---|---------------------------------|
| 1 | 42 | >21°C Increase | Multisensor | 20 |
| 2 | 45 | Not set to heat response | Carbon Monoxide | 30 |
| 3 | 52 | >21°C Increase | Multisensor | 20 |
| 4 | 57 | >21°C Increase | Multisensor | 20 |
| 5 | No response to CO | A1R* | Heat Rate of Rise; Static limit of 58°C | 15 |

* Response is A1R to EN54-5 with fixed upper threshold of 58°C

Table 4 – CO/Heat Multisensor Response Modes

9.2 Product Codes

| | | |
|--|-----------------------------------|------------------|
| Product Description | EN54-5, LPS1274 & 1265 | AS7240-5 |
| Discovery CO / Heat Multisensor | 58000-305AMP | 4106-2009 |

9.3 Technical Data:

Specifications are typical and given at 23°C and 50% relative humidity unless specified otherwise.

| | |
|--|---|
| Detector Type: | Point type detector for fire detection and alarm systems for buildings |
| Detection Principle: | CO: Ambient carbon monoxide level Heat: Temperature dependant resistance |
| Supply Wiring: | Two wire monitored supply, polarity insensitive |
| Terminal Functions: | L1 and L2 supply in and out connections +R remote indicator positive connection (internal 2.2KΩ resistance to positive) -R remote indicator negative connection (internal 2.2KΩ resistance to positive) |
| Supply Voltage: | 17 - 28V DC |
| Communication Protocol | Apollo Discovery 5-9V peak to peak |
| Quiescent Current: | 400μA at 24V DC |
| Power-up Surge Current: | 1mA |
| Maximum power up time: | 10s |
| Alarm Current, LED on: | 3.5mA |
| Remote output characteristics: | Connects positive line through 4.5KΩ (5mA maximum) |
| Clean-air analogue value: | 25 ±2 |
| Alarm-level analogue value | 55 |
| Alarm Indicator: | 2 Light Emitting Diodes (LEDs); illuminating red in alarm. Optional remote LED |
| Storage Temperature: | Continuous +10 to +30°C |
| Operating Temperature: | Continuous 0°C to +50°C Transient -20° to +55°C (no condensing or icing) |
| Operating Pressure: | Atmospheric pressure ±10% |
| Humidity: | Continuous 15 to 90% relative humidity; Transient 0 to 99% relative humidity |
| Effect of Temperature on CO Cell: | Less than 15% change in sensitivity over rated range |
| Effect of Wind on CO Cell: | None |
| Minimum CO Cell life: | 7 Years (assumes regular checks are satisfactory) |
| Transport Pressure: | If air freighted this detector should be carried in a pressurized hold |
| Vibration, Impact & Shock | To EN54 |
| IP Rating: | 44 |
| Dimensions: | Detector: 100mm Dia x 54mm H, Detector in Base: 100mm Dia x 60mm H |
| Weights: | Detector 105g, Detector in Base:160g |
| Material: | Detector housing: White polycarbonate rated V-0 in accordance with UL 94. Terminals: Nickel plated stainless steel |

10 Carbon Monoxide Detector

10.1 Operating Principles:



Discovery CO fire detectors contain a long-life electro-chemical carbon monoxide sensor which is tolerant of low levels of common vapours and household products. The sensing technology is fast, accurate and needs only very low power. The detection capabilities are enhanced by a rate sensitive response. Fast rises in the carbon monoxide level are often associated with hot fires and the detector will respond earlier under these conditions.

The analogue reply from the detector is rate limited to remove nuisance alarms resulting from short-term high levels caused by sources such as pipe smokers or gas flame ignition.

Application

CO detectors do not detect smoke particles or heat and are not universal replacements for smoke detectors. Apollo does not endorse the use of CO detectors as the main method of fire detection if:

- the protected area is an escape route
- there is a requirement to detect overheating of electrical equipment or cables
- the protected area is exposed to sources of CO such as vehicle exhausts, or to hydrogen or to high levels of alcohol vapour as emitted by some cleaning agents
- there is a requirement to detect fires involving flammable liquids

CO fire detectors are particularly suitable for supplementing smoke detection when there is:

- a deep seated smouldering fire risk
- a risk of fire starting in an enclosed space
- a likelihood of stratification taking place

Carbon monoxide detectors may be used as the primary fire detector in areas where the following conditions exist:

- the main risk is smouldering fires
- optical smoke detectors are deemed unsuitable (see 'False Alarms' below)
- the fire compartment is not greater than 50m²

Typical applications include hotel bedrooms, halls of residence, sheltered accommodation and hospital wards.

Detector Sitting

CO fire detectors should be sited using the recommendations from BS5839: Part 1 (or other applicable code).

In the development of a fire, smoke and CO in the smoke plume is spread by convection to a fire detector. As CO is a gas, it further spreads, like smells, by diffusion. For this reason CO may reach a detector faster than smoke would. This potential advantage can be exploited when designing a fire protection system and CO detectors may be used for supplementary detection. Equally, the opposite effect might occur, with CO moving away from a detector.

The behaviour of CO is therefore unpredictable and diffusion should not be relied on when designing a fire protection system.

False Alarms

Carbon monoxide detectors are less susceptible than smoke detectors to false alarms from sources such as toast, steam, cooking, plumbing work and hair spray. They may therefore be used in **some** applications in which smoke detectors would be susceptible to unwanted alarms.

Conversely, they may be more susceptible than smoke detectors to false alarms from fumes containing CO, such as vehicle exhausts, open fires and gas appliances.

Notes:

1. *Discovery CO detectors should not be used with isolating base 45681- 321. Use 45681-284.*
2. *It is necessary to wait 30s after power-up to receive valid data from the CO detector.*

Limitations

Carbon monoxide detectors also have important limitations. They are set to a higher sensitivity than the maximum allowed by the domestic CO alarm standard and will respond to CO from faulty gas appliances or vehicle exhausts. *These detectors **should not** be used in place of carbon monoxide alarms complying with BS7860 or UL2034.*

Operating Modes

The Discovery CO detector has five operating modes, each having a set combination of sensitivity and response delay, which the user can select for any given application. See table below.

Drift Compensation

In view of the inherent stability of CO cells, there is no need for Discovery CO detectors to compensate for drift. Discovery CO detectors are set to report a drift value of 16.

Cell Test

The Discovery carbon monoxide fire detector has a remote test feature, which is used to verify that the electrochemical cell is fitted and that it is active. A test must be carried out at least once a year but preferably more frequently to ensure that the cell has not dried out. (Note that the cell will not be affected by the test, even if the remote test is carried out once a day.) If the test indicates a sensor failure, i.e. the detector returns a pre-set analogue value of 25, the detector should be returned to the manufacturer for cell replacement and detector recalibration. When carrying out the cell test, observe the 30s delay referred to above.

Precautions When Investigating Alarms

It is important to remember that CO is a colourless, odourless gas, which is not directly detectable by human senses. If a CO fire detector is in an alarm condition, it is possible that a dangerous level of CO exists around the detector. *Extreme care must be taken when investigating alarms from CO fire detectors even if no combustion products can be seen or smelled.* Because of this danger, it is imperative that CO fire detectors are correctly identified at the control panel so that personnel investigating alarms may take the relevant precautions.

Maintenance and Service

The electrochemical cell used in the Discovery CO fire detector has a more limited life than would normally be expected from a smoke detector. In a typical environment, the life of the cell is seven years.

High temperature or low relative humidity can, however, reduce the life significantly. The limits given in the section '**TECHNICAL DATA**' overleaf should be carefully observed.

It is essential that systems using CO fire detectors be correctly maintained and that the maintenance schedule include functional testing of the CO fire detectors. CO fire detectors will not respond to the aerosol testers commonly used for the in-situ testing of smoke detectors. The Apollo (No Climb) detector tester with a CO test gas canister can be used to test CO detectors. If there is any doubt over the sensitivity of a Discovery CO fire detector it should be returned to Apollo for servicing and calibration.

Note: The CO detector cannot be tested with the Discovery Test Set

Health and Safety Guidelines

This product contains a sealed electrochemical cell and in normal usage represents no chemical hazard in the sense of COSHH and the Health and Safety at Work Act 1974. Chemical hazard can, however, arise if the following notes on storage, handling and disposal are not observed.

For maximum life, the product should be stored before installation in clean dry conditions between 0°C and 20°C. It should not be exposed to temperatures outside the range -40°C to +55°C or to organic vapours. The electrochemical cell contained in this product is fitted into sockets on the printed circuit board; to avoid damage to the cell do not remove it.

The electrochemical cell contains sulphuric acid in a relatively concentrated state. In the event of leakage (which may be caused by mechanical damage or use outside the operating specification for the cell) the cell should be removed from the detector using protective gloves. Avoid contact with any liquid. If skin or eye contact with the electrolyte occurs, wash immediately with plenty of water and obtain medical advice. All traces of electrolyte should be washed away with copious amounts of clean water. The cell should be disposed of according to local waste management requirements and environmental legislation. It should not be burnt since it may release toxic fumes.

| Mode | Alarm Threshold (ppm) | Minimum time to alarm (seconds) | Typical application |
|------|-----------------------|---------------------------------|---|
| 1 | 30 | 60 | Sleeping with no ambient CO |
| 2 | 45 | 30 | General use fast response such as supplementary protection in atria |
| 3 | 45 | 60 | General use and sleeping risk with some low level CO (such as from light smoking or an unventilated gas fire) |
| 4 | 60 | 30 | General smoking area and supplementary detection of deep seated fires such as laundry rooms |
| 5 | 75 | 30 | Supplementary use in kitchen or boiler room |

10.2 Product Codes

| Product Codes | | AS1603-14 |
|------------------------------------|--------------|----------------------|
| Discovery Carbon Monoxide Detector | 58000-300AMP | 201-0102 (58000-330) |

10.3 Technical Data:

Specifications are typical and given at 23°C and 50% relative humidity unless specified otherwise.

| Detector Type: | Point type detector for fire detection and alarm systems for buildings |
|-----------------------------------|---|
| Detection Principle: | Ambient carbon monoxide level |
| Supply Wiring: | Two wire monitored supply, polarity insensitive |
| Terminal Functions: | L1 and L2 supply in and out connections +R remote indicator positive connection (internal 2.2KΩ resistance to positive) -R remote indicator negative connection (internal 2.2KΩ resistance to positive) |
| Supply Voltage: | 17 - 28V DC |
| Communication Protocol | Apollo Discovery 5-9V peak to peak |
| Quiescent Current: | 300μA at 24V DC |
| Power-up Surge Current: | 1mA |
| Maximum power up time: | 10s |
| Alarm Current, LED on: | 3.5mA |
| Remote output characteristics: | Connects positive line through 4.5KΩ (5mA maximum) |
| Clean-air analogue value: | 25 ±2 |
| Alarm level analogue value: | 55 |
| Alarm Indicator: | 2 Light Emitting Diodes (LEDs); illuminating red in alarm. Optional remote LED |
| Storage Temperature: | Continuous +10 to +30°C Transient: -40°C to +55°C (no condensation or icing) |
| Operating Temperature: | Continuous 0°C to +50°C Transient -20° to +55°C (no condensing or icing) |
| Operating Pressure: | Suitable for installation up to 2,000m above sea level |
| Operating Humidity: | Continuous 15 to 90% relative humidity; Transient 0 to 99% relative humidity |
| Effect of Temperature on CO Cell: | Less than 15% change in sensitivity over rated range |
| Effect of Wind: | None |
| Minimum CO Cell life: | 7 Years (assumes regular checks are satisfactory) |
| Transport Pressure: | If air freighted this detector should be carried in a pressurized hold |
| Vibration, Impact & Shock | To EN54-7: 2000 |
| IP Rating: | 54 in accordance with BSEN60529 |
| Dimensions: | Detector: 100mm Dia x 42mm H, Detector in Base: 100mm Dia x 50mm H |
| Weights: | Detector 105g, Detector in Base:160g |
| Material: | Detector housing: White polycarbonate rated V-0 in accordance with UL 94. Terminals: Nickel plated stainless steel |

11 Heat Detector

11.1 Operating Principles:



Discovery heat detectors have a common profile with ionisation and optical smoke detectors but have a low air flow resistance case made of self extinguishing white polycarbonate.

The Discovery Heat Detector uses a single thermistor to sense the air temperature at the detector position. The thermistor is connected in a resistor network, which produces a voltage output dependent on temperature. The design of the resistor network, together with the processing algorithm in the microcontroller, gives an approximately linear characteristic from 10°C to 80°C. The linear signal is further processed, depending on the response mode selected, and converted to an analogue output.

For the European standard version of the detector, the five modes correspond to five “classes” as defined in EN54–5:2001. The classes in this standard correspond with different response behaviour, each of which is designed to be suitable for a range of application temperatures. All modes incorporate “fixed temperature” response, which is defined in the standard by the “static response temperature”. The application temperatures and static response temperatures for all response modes are given in Table 6.

In addition to the basic classification, a detector may be given an “R” or “S” suffix. The “R” suffix indicates that the detector has been shown to have a rate-of-rise characteristic. Such a detector will still give a rapid response even when starting from an ambient temperature well below its typical application temperature. This type of detector is therefore suitable for areas such as unheated warehouses in which the ambient temperature may be very low for long periods.

The “S” suffix on the other hand indicates that the detector will not respond below its minimum static response temperature even when exposed to high rates of rise of air temperature. This type is therefore suitable for areas such as kitchens and boiler rooms where large, rapid temperature changes are considered normal.

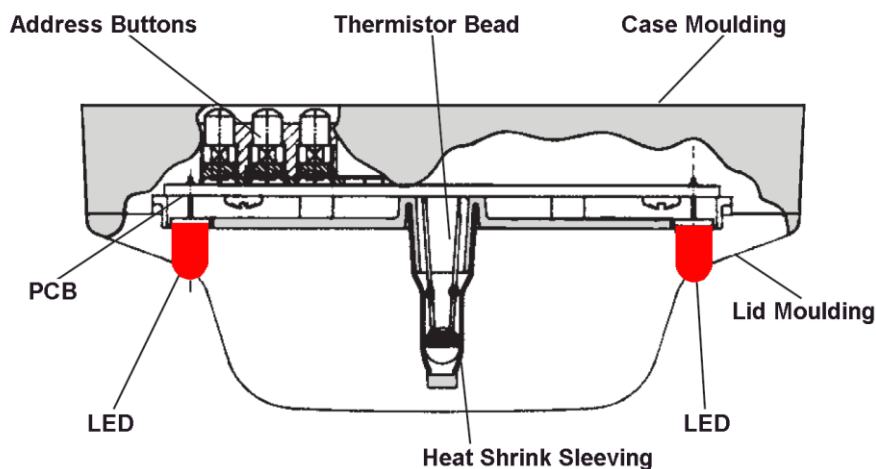

Figure 5 – Sectional View – Discovery Heat Detector

| Mode | Class EN54-5 | AS1603-1 | Application Temperature | | Static Response Temperature °C | | |
|------|-----------------|----------|----------------------------|-----|--------------------------------|---------|-----|
| | | | Typical | Max | Min | Typical | Max |
| 1 | A1R | Type A | 25 | 50 | 54 | 57 | 65 |
| 2 | A2R | Type A | 25 | 50 | 54 | 61 | 70 |
| 3 | A2S | Type B | 25 | 50 | 54 | 61 | 70 |
| 4 | CR | Type C | 55 | 80 | 84 | 90 | 100 |
| 5 | CS | Type D | 55 | 80 | 84 | 90 | 100 |

Table 6 – Heat Detector Response Modes

For air temperature in the range 15°C to 55°C, the analogue value for a detector in mode 1 will correspond approximately to the air temperature.

11.2 Product Codes

| Product Description | EN54-4 | AS7240-7 | AS1603-1 |
|-------------------------|--------------|-----------|------------------------------------|
| Discovery Heat Detector | 58000-400AMP | 4106-2007 | 201-0089 / 201-0090 (58000-430) |

11.3 Technical Data:

Specifications are typical and given at 23°C and 50% relative humidity unless specified otherwise.

| | |
|---------------------------------------|---|
| Detector Type: | Point type heat detector for fire detection and alarm systems for buildings |
| Detection Principle: | Heat sensitive resistance |
| Supply Wiring: | Two wire monitored supply, polarity insensitive |
| Terminal Functions: | L1 and L2 supply in and out connections +R remote indicator positive connection (internal 2.2KΩ resistance to positive) -R remote indicator negative connection (internal 2.2KΩ resistance to positive) |
| Supply Voltage: | 17 - 28V DC |
| Communication Protocol | Apollo Discovery 5-9V peak to peak |
| Quiescent Current: | 400μA at 24V DC |
| Power-up Surge Current: | 1mA |
| Maximum power up time: | 10s |
| Alarm Current, LED on: | 3.5mA |
| Remote output characteristics: | Connects positive line through 4.5KΩ (5mA maximum) |
| Alarm level analogue value: | 55 |
| Alarm Indicator: | 2 Light Emitting Diodes (LEDs); illuminating red in alarm. Optional remote LED |
| Temperature Range: | Maximum operating – refer table above Minimum operating (no condensing/icing) -40°C Storage -40°C to +80°C |
| Operating Humidity: | 0 to 90% relative humidity (no condensation) |
| Vibration, Impact & Shock | To EN54-5: 2001 |
| IP Rating: | 54 in accordance with BSEN60529 |
| Dimensions: | Detector: 100mm Dia x 42mm H, Detector in Base: 100mm Dia x 50mm H |
| Weights: | Detector 105g, Detector in Base:160g |
| Material: | Detector housing: White polycarbonate rated V-0 in accordance with UL 94. Terminals: Nickel plated stainless steel |

12 Mounting Bases

12.1 Technical Description:



| Item No | Description |
|--------------|--|
| 45681-210AMP | XP95/Discovery Detector Base with Xpert Card |

All detectors in the Discovery range fit into XP95 mounting bases. An earth connection is not required for either safety or correct operation of detectors. The ground (earth) terminal is isolated and

is provided for tidy termination of grounded conductors or cable screens and to maintain earth continuity where necessary. All terminals are marked according to their function.

Bases have a wide interior diameter for ease of access to cables and terminals and there are two slots for fixing screws. The slots enable two fixing screws to be located at a spacing of 51 to 69mm.

Detectors fit into bases one way only, without snagging, and require clockwise rotation without push force to be plugged in.

Universal address cards, known as XPERT cards, are supplied with all bases. Consult the coding guide in the installation instructions to determine which pips are to be removed from the card to give the correct address. Lay the card on a flat surface, pips down, insert a screwdriver into the slot on the reverse of the pip to be removed and give a firm twist.

When the card is coded, insert it into the slot in the side of the appropriate base, making sure that the card locks itself into place. As a detector is inserted into the base, the remaining pips operate the address buttons on the detector and the detector electronics reads the address.

The bases are 100mm diameter and have five terminals:

| Terminal | Description | Type |
|----------|----------------------------|-----------------|
| L1 | Line In and Line Out | Double Terminal |
| L2 | Line In and Line Out | Double Terminal |
| -R | Remote LED negative supply | Double Terminal |
| +R | Remote LED positive supply | Double Terminal |
| E | Earth | Single Terminal |

13 Manual Call Point

13.1 Operating Principles:



| Item No | Description |
|--------------|---|
| 58100-908AMP | Discovery Manual Call Point with Isolator |
| 58100-910AMP | Discovery Manual Call Point |

The Discovery EN54–11:2001 compliant Manual Call Point (MCP) is based on the KAC conventional MCP range. It is electronically and mechanically compatible with previous call points based on KAC’s World Series product.

The address of each call point is set at the commissioning stage by means of a seven-segment DIL switch. If an MCP is activated, it interrupts the normal protocol to give a fast response.

A single bi-coloured alarm LED is provided on the call point. This LED is controlled, independently of the call point, by the control panel and may be set to flash each time the call point is polled. The red LED is lit when the call point has been activated and sent into alarm. On the isolated versions an amber/yellow LED indicates a short circuit on the loop wiring either side of the call point.

Call points can be remotely tested from the panel by transmission of a single bit in the communications protocol. Call points respond by providing a value of 64 which corresponds to the alarm value. The panel should recognise this response as a test signal and should not raise a general alarm.

The Discovery Manual Call Point incorporates an integral short circuit isolator together with a resettable element and a backbox for surface mounting as standard. If a glass option is required, spare glasses are available on request. For ease of installation Discovery manual call points are supplied with clip-on terminal blocks and a connector which allows continuity testing before call points are commissioned.

To provide additional protection against accidental operation, a transparent hinged cover with a locking tag, is available, which can be fitted to the manual call point. Please note that the call point does not conform to EN54-11:2001 when this lid is fitted and secured with the locking tag.

13.2 Non Standard Call Points:



Discovery waterproof (IP67) manual call points are available in red or yellow. For special purposes, such as initiating 'Hazard' alarm, specially coloured call points can be used on the fire system – see table below. However, these do not conform to EN54-11:2001 requirements.

| Item No | Colour | Deformable Element | Backbox for surface | Isolator | Non-Isolator | Waterproof IP67 Rated |
|----------------------------|--------|--------------------|---------------------|----------|--------------|-----------------------|
| 58100-908AMP | Red | • | • | • | | |
| 58100-951AMP (213-0067) | Red | • | • | • | | • |
| 58100-926 | White | • | • | | • | |
| 58100-927 | Yellow | • | • | | • | |
| 58100-928 | Blue | • | • | | • | |
| 58100-929 | Green | • | • | | • | |
| 58100-953 | Yellow | • | • | • | | • |

Table 7 – Manual Call Point Item Numbers

13.3 Technical Data:

Specifications are typical and given at 23°C and 50% relative humidity unless specified otherwise.

| Call Point Type: | Deformable element |
|-------------------------|---|
| Call Point Principle: | Operation of a switch |
| Alarm Indicator: | Red Light Emitting Diode (LED) |
| Fault Indicator: | Amber/Yellow Light Emitting Diode (LED) |
| Supply Wiring: | Two wire monitored supply, polarity insensitive |
| Loop Connections: | Terminal Block L1 –ve and L2 +ve supply in and out connections |
| Operating Voltage: | 17 - 28V DC |
| Communication Protocol: | Apollo Discovery 5-9V peak to peak |
| Quiescent Current: | 100µA at 24V DC |
| Power-up Surge Current: | 1mA |
| Maximum power up time: | 1s |
| Alarm Current, LED on: | 4mA |
| Normal analogue value: | 16 |
| Alarm State Value: | 64 |
| Temperature Range: | -20°C to +60°C |
| Humidity: | 0 to 90% relative humidity (no condensation) |
| Compliance Standard: | To EN54-11: 2001, EN54-17:2005 (isolated version) |
| IP Rating: | 24D IP67 (weatherproof) |
| Dimensions: | 89mm x 93mm x 26.5mm (manual call point) 87mm x 87mm x 32mm (back box) |
| Weights: | Flush Mounted: 110g Surface Mounted: 160g |
| Material: | Housing: Red self-coloured polycarbonate/ABS |

Ancillary Items:

| Item No | Description |
|-----------|---|
| 26729-152 | Hinged Cover |
| 26729-179 | Security Locking Tags for above (pack of 5) |
| 26729-155 | Discovery Glasses |

14 Interfaces



A comprehensive range of interfaces for use with Discovery systems and incorporating the Ampac fire alarm control panels is available. They are designed to enable fire protection systems to be engineered simply and effectively without the need for custom-designed equipment.

These interfaces are available in three types of housing. The standard interfaces are designed to be surface or flush-mounted while the DIN-rail versions feature enclosures that clip to a standard 35mm DIN rails (DIN46277) or are screwed to the base of a larger enclosure. Miniature interfaces use very compact enclosures for installation into other equipment.

The standard interface range is fitted with bi-directional, short-circuit isolators. These interfaces allow for easier installation when large numbers of interfaces are required.

The following interfaces may be incorporated into Discovery systems:

- Input/Output Unit provides a relay output and one monitored input
- 3-channel Input/Output Unit provides 3 relay outputs and 3 monitored inputs
- Mains Switching Input/Output Unit switches machinery operating at 230V
- Output Unit provides one relay output
- Zone Monitor controls a zone of conventional detectors
- Switch Monitor monitors the operation of a switch
- Switch Monitor Plus monitors the operation of a switch; also incorporates a time delay
- Sounder Controller controls the operation of conventional sounders
- Mini Switch Monitor monitors the operation of a switch and is small enough to fit into other equipment

For further information on the range of compatible interfaces refer to Ampac Product Guide MAN3040.

15 Isolators



All XP95 isolators and isolating bases are suitable for use with Discovery detectors and manual call points. These are:

For further information on the use of isolators in Discovery systems refer to Ampac Product Data sheet PDS201-9001.

15.1 Product Codes

| Product Description | Product Number | Item Number |
|---|----------------|-------------|
| XP95/Discovery Isolating Base with Xpert Card | 45681-284AMP | 201-0125 |
| XP95/Discovery Isolator | 55000-720AMP | 201-0172 |
| XP95/Discovery Isolator Base (for above) | 45681-211AMP | 201-0006 |

16 Sounder Beacon Base



The Discovery Sounder Beacon Base is a multifunctional device comprising a mounting base for Discovery fire detectors, a sounder, a beacon and a short-circuit isolator.

The Discovery Sounder Beacon Base is used to provide audible and visual warning of fire and is controlled by the fire control panel by means of the Discovery protocol. The particular features of this base are available only when it is being controlled by the full Discovery protocol with the panel programmed accordingly. Information on features should be requested from the panel manufacturer.

The Discovery Sounder Beacon Base can be used with a detector fitted or with a cap for operation as a stand-alone alarm device.

The right tone for your installation

The Discovery Sounder Beacon Base offers a choice of 15 evacuation tones, including a standard evacuation tone. One of these tones is selected during commissioning in order to suit local regulations or customs. The tones include those required by Dutch, Swedish, German, Australian, New Zealand and North American standards as well as the UK. Whichever evacuation tone is selected there is a secondary tone which may be used for alerting or warning of a possible evacuation.

The right level of sound

The sounder is set during commissioning to one of 7 levels of sound, the highest level being nominally 90dB(A). At 60dB(A) the lowest level falls outside the scope of the standard, EN54. It has been included to provide a very local warning for the use of personnel in particular environments, such as nurse stations in hospitals.

Flexibility of group addressing

In many installations a fire alarm must be raised by switching more than one sounder beacon to alert or alarm simultaneously. This is achieved with Discovery Sounder Beacon Bases by assigning devices to groups on commissioning, with the group information being stored in each device. One command will then switch all devices in the group.

Sounder, beacon or both

The Discovery Sounder Beacon Base normally switches both sounder and beacon to provide an alert or evacuation signal. The sounder and beacon of the Discovery Sounder Beacon Base can, however, be switched independently of each other by the control panel.

Location-specific volume setting

Detectors and sounder beacons are installed in many different types of environment. When configuring the Discovery Sounder Beacon Base, the adjustment of volume can be done at the point of installation. The commissioning engineer simply sets the control panel to 'Setup' and then walks from one device to the next to set the required volume, using a magnetic wand, part no 29650-001.

When all devices have been set the control panel is used to register all the individual volume settings.

Features

- 15 evacuation tones and 15 secondary or alert tones
- 7 volume levels
- Software-defined group addressing
- Alarm switching by individual device, by group or of all devices on loop
- Independent control of sounder and beacon
- Set-up and testing of devices at point of installation
- Isolator status information

| Product Description | EN54-3 |
|--|--------------|
| Discovery Sounder Beacon Base with Indicator | 45681-393AMP |
| White Base Sounder Cap | 45681-292 |
| Red Base Sounder Cap | 45681-293 |

Technical Data:

Specifications are typical and given at 23°C and 50% relative humidity unless specified otherwise.

| | |
|---|--|
| Audio/Visual Type: | Point type sounder/beacon for fire detection and alarm systems for buildings |
| Operating Voltage: | 17-28V d.c. (polarity sensitive) |
| Protocol Pulses: | 5-9V |
| Current consumption at 24V: | Switch on surge, <1s = 1.2mA Quiescent = 350µA Device operated at maximum volume = 8mA |
| Maximum sound output at 90°: | 90±3dB(A) Sound pressure level data is published in Product Data Sheet PDS201-9002 |
| Operating Temperature: | -20°C to +60°C |
| Humidity (no condensation or icing): | 0-95% |
| IP Rating: | 21D |

Note: do not connect XP95 sounders if Discovery sounders are being used.

17 Open Area Sounder Beacon



The Discovery® Open Area Sounder Beacon is an alarm device comprising a sounder, a beacon and a short circuit isolator for use with Discovery detection systems. It is supplied with a mounting base which incorporates a short-circuit isolator.

The Discovery Open Area Sounder Beacon is used to provide audible and visual warning of fire and is controlled by the fire control panel by means of the Discovery protocol. The particular features of this sounder beacon are available only when it is being

controlled by the full Discovery protocol with the panel programmed accordingly. Information on available features should be requested from the panel manufacturer.

Features & advantages

These are identical to the Discovery Sounder Beacon Base but the Open Area Sounder Beacon is a wall mounted stand alone device that produces a higher sound output of up to 100dB(A).

| Product Description | EN54-3 |
|--|--------------|
| Discovery Sounder Beacon Red Open-Area | 58000-005AMP |
| Discovery Sounder Beacon White Open-Area | 58000-007AMP |

Technical Data:

Specifications are typical and given at 23°C and 50% relative humidity unless specified otherwise.

| | |
|--------------------------------------|--|
| Visual Type: | Point type beacon for fire detection and alarm systems for buildings |
| Operating Voltage: | 17-28V d.c. (polarity sensitive) |
| Protocol Pulses: | 5-9V |
| Current consumption at 24V: | Switch on surge, <1s = 1.2mA Quiescent = 350µA Device operated at maximum volume = 8.2mA |
| Maximum sound output at 90°: | 100dB(A) Sound pressure level data is published in Product Data Sheet PDS201-9002 |
| Operating Temperature: | -20°C to +60°C |
| Humidity (no condensation or icing): | 0-95% |
| IP Rating: | 65 |

18 Maintenance of Detectors

Detectors should be maintained according to BS5839 or other locally applicable code. Test equipment can be ordered from Ampac for testing smoke and heat detectors. Detectors should not be cleaned in the field except for careful removal of exterior dirt with a damp cloth. For cleaning and recalibration detectors should be returned to the manufacturer or to the local distributor.

19 Application of Discovery Detectors

The process of designing a fire detection system using Discovery detectors is the same as that used for any other detector range, except that Discovery offers more choices to the system designer. The principles set out in relevant codes of practice such as BS5839: Part 1 should be followed in any system design. The notes below are intended to supplement the codes of practice and to give some specific guidance on the choices available with the Discovery range.

Choice of Detector Type

The choice of detector from the Discovery range follows the well established principles of system design. That is, the optimum detector type will depend on the type of fire risk and fire load, and the type of environment in which the detector is sited.

For general use, smoke detectors are recommended since these give the highest level of protection. Smoke detectors from the Discovery range may be ionisation, optical or multisensory types. The most widely used single sensor detector is the optical smoke detector. For the greatest versatility in designing fire detection systems the optical/heat multisensor is the detector of choice.

Ionisation smoke detectors are excellent at detecting small particle smoke and providing early warning of a fire but they must be used in an environmentally friendly way.

The optical/heat multisensor is basically an optical smoke detector and will therefore respond well to the smoke from smouldering fires. In response modes 1, 3 and 4, however, (ie, in the multisensor modes) the detector also senses air temperature. This temperature sensitivity allows the multisensor to give a response to fast burning (flaming) fires which is similar to that of an ionisation detector. The multisensor can therefore be used as an alternative to an ionisation detector while still retaining the benefits of an optical smoke detector.

Where the environment is smoky or dirty under normal conditions, a heat detector may be more appropriate. It must be recognised, however, that any heat detector will respond only when the fire is well established and generating a high heat output. The Discovery heat detector can be used in a wide range of conditions by selecting the correct mode (see Table 9).

The relative performance of the six detector types for different fire types is given in Table 8.

Choice of Response Mode

A major objective in designing a detection system is to achieve the best detection performance while keeping the number of unwanted alarms at a low level. Unwanted alarms are normally caused by environmental influences. For any given environment, unwanted alarms will, as a rule, be more frequent for detectors of higher sensitivity.

It has already been pointed out that the response modes for Discovery detectors correspond to different sensitivity to fire, with response mode 1 being more sensitive than mode 5. It follows, then, that Discovery

detectors set to mode 1 will be most suitable for environments in which sources of unwanted alarms are rare. Such environments include clean rooms and computer suites.

At the other extreme, response mode 5 will be suited to more dusty or smoky environments such as loading areas where diesel forklift trucks are operating. Response mode 3 is a general-purpose setting for which the response is similar to that of the corresponding XP95 detector.

It will be seen, then, that it is often more useful to think of particular response modes being suited to different environments rather than simply having different sensitivity to fire. Table 9 shows response modes for Discovery detectors that are considered suitable for different environment types. Any of those identified as suitable should give acceptable performance. The recommended detector/mode combinations will give the best available performance from Discovery.

Time-related systems

Discovery detectors are particularly useful for installations in which it is desirable to set different detector response characteristics at different times of the day because of changes in the environment. For example, if an industrial process generates smoke or fumes during working hours and the area is clean at other times the optimum response mode will be different at different times of the day. Outside working hours the sensitivity can be switched to a higher level to maintain maximum protection.

The Discovery multisensor is especially suitable for time-related systems. Because its response can be switched from a pure heat response to a sensitive multisensor smoke response, it can be optimised for very clean or dirty (smoky) environments. However, if mode switching between heat and smoke (or multisensor) modes is used, it is important to remember that the area coverage in the heat-only mode is less than that of the smoke or multisensory modes. *The detector spacing must therefore be based on the heat detector spacing of the relevant standard.*

| | Optical | Multisensor | Ionisation | CO/Heat | CO | Heat |
|-----------------------------------|-----------|----------------|----------------|----------------|-----------|----------------|
| Overheating/thermal decomposition | Very Good | Very Good | Poor | Very Poor | Very Poor | Very Poor |
| Smouldering/glowing combustion | Good | Good | Moderate /Good | Excellent | Excellent | Very Poor |
| Flaming combustion | Good | Good | Very Good | Moderate | Poor | Poor |
| Flaming with high heat output | Good | Very Good | Very Good | Very Good | Moderate | Moderate /Good |
| Flaming – clean burning | Very Poor | Moderate /Good | Poor | Moderate /Good | Very Poor | Moderate /Good |

Table 8 – Relative Performance of Detectors in Test Fires

| | Cleanroom EDP Suite | | | | | Hotel Room, Studio, Small Flat (<50m ²) | | | | | Office, Long Corridor, Hospital Wards Light Industry Factory | | | | | Warehouse, Bar | | | | | Loading Bay Car Park (enclosed & ventilated) | | | | | Kitchen, Laundry | | | | | Boiler Room | | | | |
|---------|------------------------|---|---|---|---|--|---|---|---|---|--|---|---|---|---|-------------------|---|---|---|---|---|---|---|---|---|---------------------|---|---|---|---|-------------|---|---|---|---|
| | 1 | 2 | 3 | 4 | 5 | 1 | 2 | 3 | 4 | 5 | 1 | 2 | 3 | 4 | 5 | 1 | 2 | 3 | 4 | 5 | 1 | 2 | 3 | 4 | 5 | 1 | 2 | 3 | 4 | 5 | 1 | 2 | 3 | 4 | 5 |
| Optical | | | | | | | | | | | | | | | | | | | | | | | | | | | | | | | | | | | |
| Multi | | | | | | | | | | | | | | | | | | | | | | | | | | | | | | | | | | | |
| Ion | | | | | | | | | | | | | | | | | | | | | | | | | | | | | | | | | | | |
| CO/Heat | | | | | | | | | | | | | | | | | | | | | | | | | | | | | | | | | | | |
| CO | | | | | | | | | | | | | | | | | | | | | | | | | | | | | | | | | | | |
| Heat | | | | | | | | | | | | | | | | | | | | | | | | | | | | | | | | | | | |

KEY ■ Recommended ■ Suitable S Suitable as supplement

Table 9 – Discovery Response Mode Selection Grid

20 Acknowledgement

The Discovery range of detectors and products are manufactured for Ampac by Apollo Fire Detectors Ltd.

UNCONTROLLED DOCUMENT

NOTE: Due to AMPAC's commitment to continuous improvement specifications may change without notice.