



Fire detection and evacuation solutions that save lives.



LoopMaster

(N.Z.S. 4512:2010)

Configuration Software

MAN2999-2

Contents

1	About This Manual	4
2	Getting Started with Project Wizard / Project Creation	5
3	Programming Concepts	7
3.1	I/O Programming Model.....	7
3.1.1	Cause and Effects Programming.....	8
3.1.2	Zone Programming	8
3.1.3	Global Programming.....	9
3.1.4	Global Sounder Programming.....	10
3.2	Configuration Programming	15
3.2.1	System Level.....	15
3.2.2	Panel Level	15
3.2.3	Loop Level	15
3.2.4	Zone Level.....	16
3.2.5	Input Level	20
3.2.6	Output Level	21
3.3	On Site Programming / Auto learn.	22
3.4	Software Download.....	22
4	General Overview	23
4.1	The Main Screen	23
5	Top Level (Main) Functionality.....	24
5.1	Introduction	24
5.2	The Main Menu.....	24
5.2.1	File Menu	24
5.2.2	Export Menu	24
5.2.3	Edit Menu	25
5.2.4	View Menu.....	25
5.2.5	Tools Menu	25
5.2.6	Help Menu	25
5.3	The Main Toolbar	26
5.4	Derived Functionality	27
5.4.1	Open.....	27
5.4.2	Save As.....	27
5.4.3	Export / Select Loop	28
5.4.4	Save SimSystem File	29
5.4.5	Print Setup	29
5.4.6	Print with Preview	30
5.4.7	Select All	31
5.4.8	Print.....	31
5.4.9	Application Colours	32
5.4.10	Communications	34
5.5	Events	37
6	Sub Level (Tree & Details Pane) Generic Functionality	40
6.1	The Tree View Toolbar	40
6.2	Zone Manager	42
6.3	Cause & Effect	48
6.4	Security Settings.....	57

6.5	Notes	58
6.6	The Details Pane Toolbar	59
7	Configuring Panels	60
7.1	The Details View	60
7.2	The List View	60
7.3	Editing	61
7.4	The Panel Menu	63
7.5	Panel I/O - Inputs	63
7.6	Panel I/O - Outputs	66
8	Configuring Loops & Devices	69
8.1	Editing a Device without I/O	72
8.2	Editing a Device with I/O	75
8.3	Devices	79
8.3.1	Selecting	79
8.3.2	Drag & Drop	80
8.3.3	Selecting	81
8.3.4	Drag & Drop	82
8.3.5	The Grid Menu	82
8.3.6	The Device Explorer	82
8.4	Device Types	84
8.5	Apartment Module	87
8.5.1	Configuring an Apartment Module	87
8.5.2	Configuring a Cause and Effect for an Apartment Module	91
9	Panel Add-Ons	93
9.1	SmartTerminal	94
9.2	LED Index	97
10	Remote Control	101
10.1	Operation	101
10.2	Transfer	102

1 About This Manual

The Windows configuration software **LoopMaster** is used to construct a configuration ‘file’, suitable for ‘programming’ the **LoopSense** Fire Alarm Control Panel (FACP).

‘File’ refers to the collection of configuration parameters that are either sent to or received from the FACP, that allow the user to either program it to perform certain functions or to view how the panel is currently programmed.

‘Programming’ refers to the processing / storing of configuration data into the panel’s non-volatile memory such that the panel will perform required the functions as set up by the user.

The supported operating systems are:

- Windows 2000 Professional/Server
- Windows XP
- Windows 2003 Server
- Windows Vista
- Windows 7

2 Getting Started with Project Wizard / Project Creation

From the Start Menu click the **LoopMaster** exe file as shown below

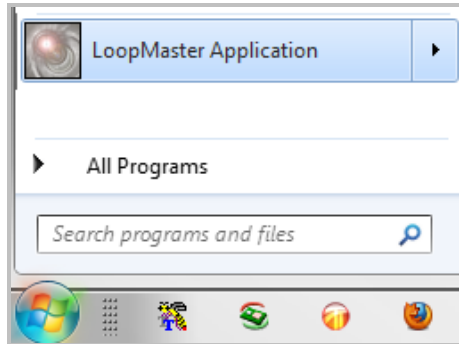

Figure 1: LoopMaster Start Menu

The following screen will appear as LoopMaster Boots.



Figure 2: LoopMaster Start Screen

Once LoopMaster Boots the following screen is presented, this allows the user to select the correct Standard to be selected. In this case NZS4512 NZL Apollo is selected

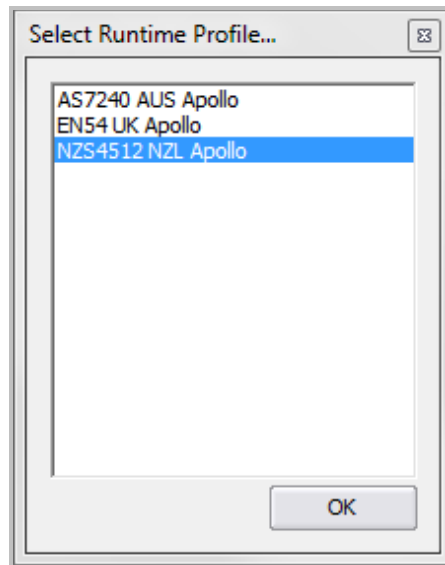

Figure 3: Standard Selection Screen



Figure 4: Project Wizard Screen

Once the Standard is selected the The “Project Wizard Screen” will open as shown above allowing you to:

- Left click on “Create” to start the “Project Wizard” to create a new project, or
- Select “Open last saved project”, or
- Select “Open default project” and locate the desired project using the “drop down box”. Of note is – this project, if used will be opened by default the next time **LoopMaster** is executed.

3 Programming Concepts

The FACP is considered as a collection of inputs and outputs. Examples of inputs are detectors, monitored inputs available at the panel, inputs available via loop devices, day/night mode and timers. Examples of outputs are monitored outputs available at the panel, relays available at the panel, loop based sounders, loop based beacons, loop based relays and so forth.

The programming model is based around assigning attributes to the inputs and outputs. These attributes determine how an input is handled by the FACP, and which outputs are activated and how they are activated in response to the change in the input.

The FACP programming consists of two parts, one being the configuration of the physical components of the system, and secondly how changes in the inputs result in changes in the outputs or I/O programming.

The FACP programming can be done using the PC configuration software or via the front panel of the FACP using the access level 3 programming menu. The front panel programming is limited as it does not support all the configuration features of the PC configuration software such as Cause and Effects programming, however it does support the common programming tasks such as adding and deleting devices and assigning attributes such as action types.

3.1 I/O Programming Model

All inputs and outputs in the system are zoned (Z1 to Z999: Default Z1).

Inputs zones can be configured to cause an action type event to occur on the system; Output zones can be programmed to react to these action type events. There are eight action types available at the panel these are listed in priority order:

- Fire
- Fault
- Pre-Alarm
- Emergency
- Security
- User
- Transparent
- System

There are essentially three methods of programming outputs to react to input activations; these are (listed in order of priority):

- Cause and Effects programming
- Zone programming
- Global programming

3.1.1 Cause and Effects Programming

Cause and Effects (C&E) is a configuration feature that is available via the PC configuration software. This allows combinations of inputs and zones classified as inputs to be assigned as activators (causes) to cause outputs to activate (effects) using logical operation and delays. This also allows the flexibility of having causes to invoke the following system events:

- Zone Disable
- Walk Test
- Day-Night mode change
- Master Reset
- Evacuate
- Alert
- Class Change
- Force Access Level 2
- Buzzer Silence
- Silence/Resound

The following events can also be included as a cause:

- Panel in alarm
- Panel in day mode
- Panel in night mode
- Panel silenced
- Panel reset

The use of Virtual Points is also supported in C&E programming. This allows the programmer to link the effect of one C&E to the cause of another. Virtual points are panel wide.

3.1.2 Zone Programming

There are 1-999 Zones and a Global Zone available within the system. All inputs assigned to a zone shall report abnormal conditions prioritized collectively for that zone. Zones may be programmed such that all fire inputs within the zone shall report a fire condition subject to zone input configurable attributes and can be set for day and/or night modes individually. The available zone input configuration types include:

- Normal
- Investigation
- Dependency A
- Dependency B
- Dependency C
- Alarm Verification Facility (AVF)

Output zones can be programmed to respond to any action type in any input zone. The way the output zones respond to an action type in an input zone will be one of the following:

- Off: no response
- On or Evacuate: Note with the Hochiki wall and base sounders the volume and tone can be selected
- Delayed: output is delayed prior to being switched on
- Alert: output to pulse at 1 second on 1 second off
- Alert timeout On, the output is set to alert, then on expiry of the timer the output is set to on

3.1.3 Global Programming

Global programming allows inputs that cause a fire event to occur to activate all outputs in the system to activate according to their global output programming attributes.

There are four default output programming options:

1. Global Alert: Set all outputs to the Alert tone with an optional delay.
2. Global Evacuate: Set all outputs to the Evacuate tone with an optional delay.
3. Zone Evacuate: Set all outputs in an alarm zone to evacuate
4. 2 Stage– Set all outputs in the alarm zone to Evacuate and all other zones to Alert, with a timeout option to set the Alert zones to Evacuate.

The following example illustrates the effect of a Fire event occurring in Zone 1 when all zones are configured for Zone Evacuate:

Z2 No Effect	Z3 No Effect	Z4 No Effect
Z5 No Effect	Z1 EVAC	Z6 No Effect
Z7 No Effect	Z8 No Effect	Z9 No Effect

When Zone 1 enters a Fire condition, all the outputs in Zone one will activate in Evacuate mode. Note that outputs configured for C&E in zone 1 will be activated according to the C&E programming as a matter of priority.

The following example illustrates a 2 Stage configuration where a Fire event occurs in Zone 1:

Z2 Alert (Timeout EVAC)	Z3 Alert (Timeout EVAC)	Z4 Alert (Timeout EVAC)
Z5 Alert (Timeout EVAC)	Z1 EVAC	Z6 Alert (Timeout EVAC)
Z7 Alert (Timeout EVAC)	Z8 Alert (Timeout EVAC)	Z9 Alert (Timeout EVAC)

When Zone 1 enters a Fire condition, all the outputs in Zone one will activate in Evacuate mode, and all surrounding zones will operate in alert mode with the option of timing out to Evacuate mode. Note that outputs configured for C&E in zone 1 will be activated according to the C&E programming as a matter of priority. Furthermore Zone programming of outputs has priority over the global programming.

3.1.4 Global Sounder Programming

Global Sounder programming allows all sounder outputs in the system to activate according to their sounder output programming attributes. The global sounder programming available within the PC configuration tool shall set all output and zone configurable attributes to respond in 1 of four methods:

- Global Alert: Set all outputs to the Alert tone with an optional delay.
- Global Evacuate: Set all outputs to the Evacuate tone with an optional delay.
- Zone Evacuate: Set all outputs in an fire zone to evacuate
- 2 Stage: Set all outputs in the fire zone to Evacuate and all other zones to Alert, with a timeout option to set the Alert zones to Evacuate.

3.1.4.1 Sounder Grouping

Sounder manufacturers have implemented separate schemes for activating multiple sounders at the same time. All schemes rely on grouping sounders together, and then using the group number to activate a collection of sounders. If the group is associated with a zone, then zones of sounders can be activated by using the group number. If an all alert or all evacuate type algorithm is required, it may be more appropriate to associate the group with all sounders. As a result the following has been implemented.

Apollo Sounder Grouping

Considering the Apollo XP95 Sounder Grouping:

- Fifteen group addresses per loop. Means device addresses from 112 to 126 are not available for device allocation but may be used for sounders within the same group (See Figure 5)
- Group number is set by DIP switch on the device itself
- Sounder can only be in one group.

Panel configuration

- Sounder Groups are assigned to the individual sounder at device output level (Figure 4)
- Zones are assigned to Sounder Groups at loop level (Figure 3)
- Sounder Group activation attributes are settable at loop level (Figure 3)

Therefore groups of sounders can be mapped to zones which can be controlled via the panel programming using:

- Cause and Effects Zone Outputs
- Action Type Zone Outputs (Zones 1 to 999)
- Action Type Global Zone Outputs

When the individual sounder output is assigned to a sounder group it adopts the zone number of which the group is assigned at loop level and the associated activation attributes. The activation attributes settable for each sounder group at loop level include the Action Types which the group shall respond to, the Silenceable option, and response to Class Change and Alert/Evacuate.

The grouping block consists of two types of fields: (Figure 3)

1. Editable fields:

- Action Types: The user can select one or more Action Type to associate with this group by checking or un-checking the relevant check box.
- Responds To:
- Class Change: Specifies that this group’s outputs will respond to a Class Change request.
- Alert / Evacuate: Specifies that this group’s outputs will respond to an Evacuate request.
- Silenceable: This checkbox is checked to force this group’s outputs to become silenceable.
- Zone: Allows entering of a zone number between 0 and 999.

Non-editable (informational) fields:

- Address: The loop address that this group will appear as.
- Switch Setting: The representation of the way the DIP switch must be set to ‘enable’ the address above.

Configuring a Sounder Group

In the Panel loop details screen, double-clicking on any entry in this list will open the Sounder Grouping editing dialog box for that particular loop.

Number	Name	Descriptor	Ref	Loop Termination
1	Loop 1	LOOP 1	1	Redundant

Figure 5: Loop Descriptor and Termination Type

The Sounder Group is then configured by selecting a zone value. (A zone value is then associated with the Sounder Group) and by selecting the applicable Action Types and Responds to options

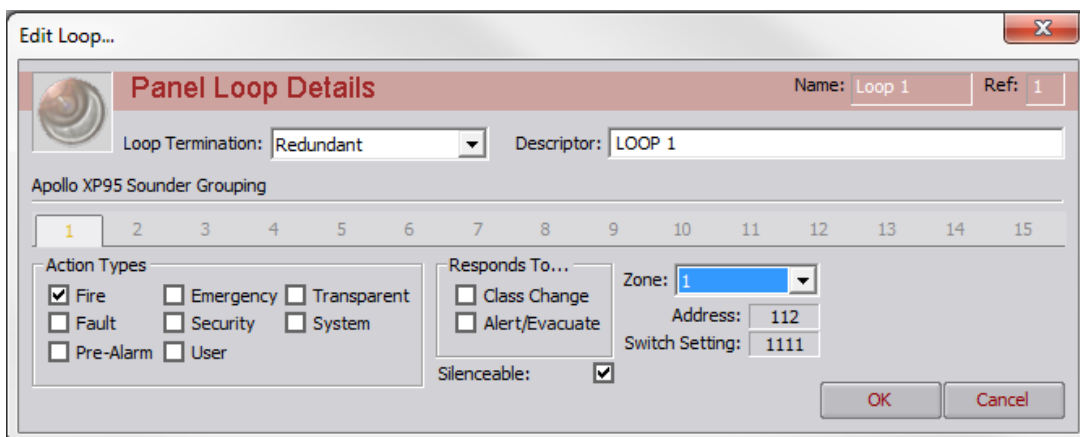

Figure 6: Sounder Grouping

In the individual Sounder device screen the Group option is now available for selection. The Zone option is greyed out as the Sounder Group Zone takes priority.

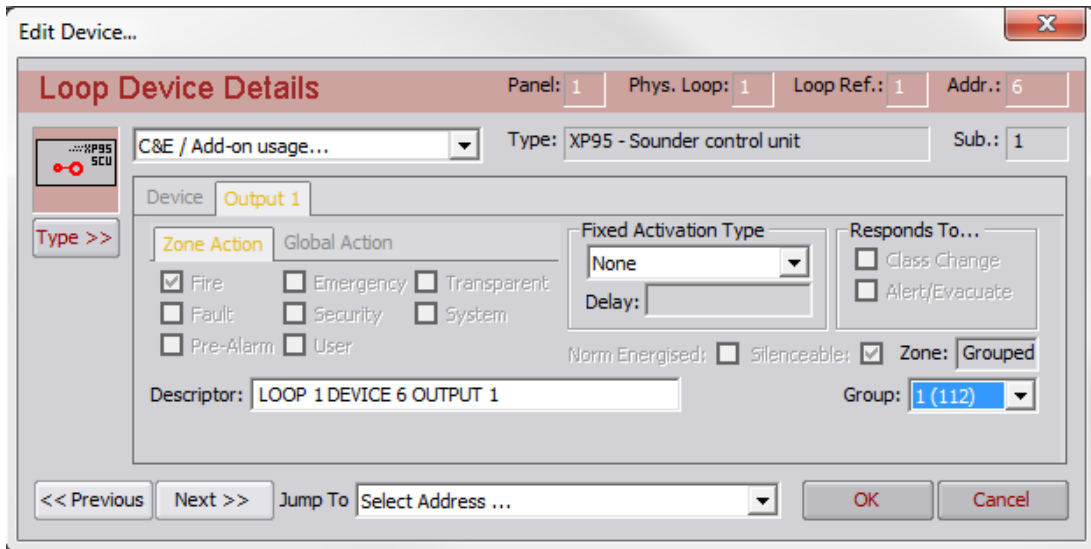

Figure 7: Edit Device Screen Note: Group 1 (112)

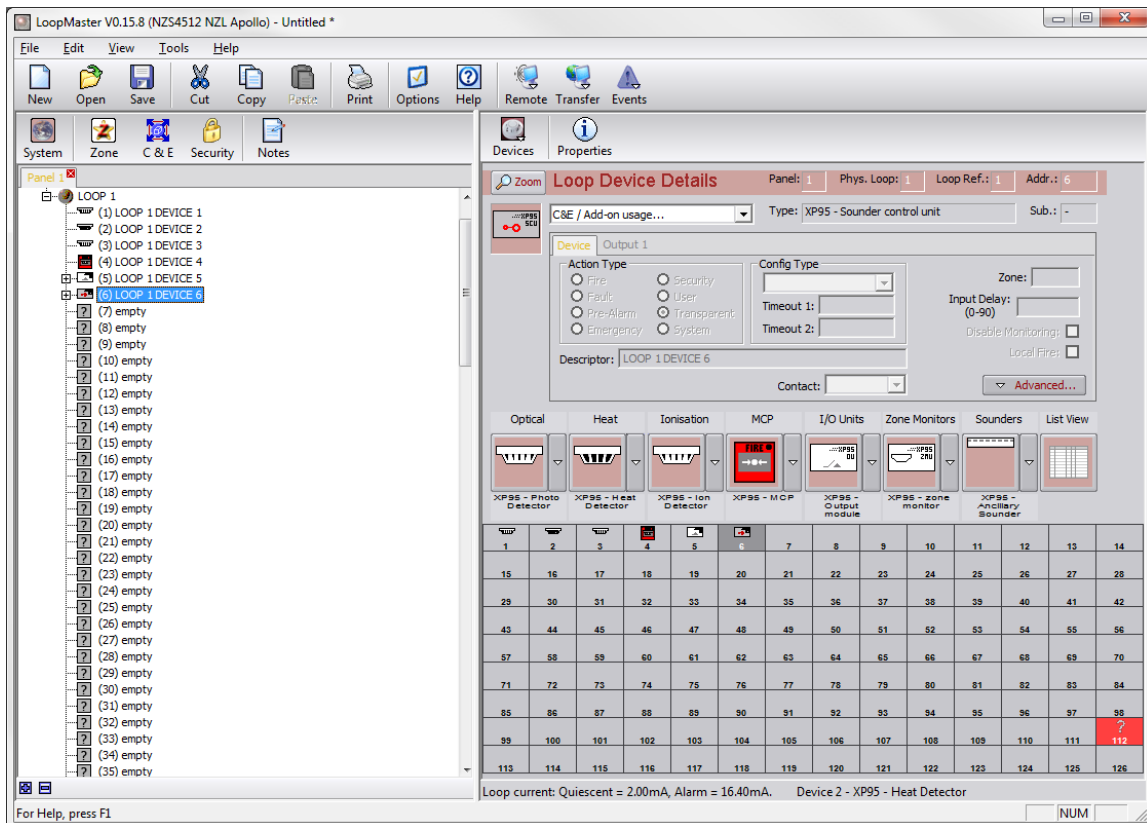

Figure 8: Sounder Grouping showing the reserved addresses (Group1 (112))

Considering the Apollo Discovery Sounder Beacon (DSB) Grouping:

The following devices currently support Discovery sounder grouping:

- Discovery Sounder Beacon Base
- Discovery Open-Area Sounder Beacon

These devices support soft group addressing of up to 16 groups. The LoopSense FACP dynamically allocates the DSB to sounder groups based on the configured activation attributes of the sounders. The possible activation attributes which cause the sounders to activate by group include:

- Responds to Alert/Evacuate
- Responds to Class Change
- Silenceable
- Zone Action Settings
- Global Action Settings
- Cause and Effects Zone Output programming

Sounders which share the same activation attribute settings shall be automatically allocated to a sounder group to facilitate rapid activation. As there are 16 group addresses available, the group containing the largest amount of sounders shall be allocated to the first group address, and then the second largest group shall be allocated to the second group address and so on until all 16 group addresses are filled. As each loop can have up to 16 group addresses, it would be rare to fill all group addresses. In the event that more than 16 groups exist on one loop, the sounders in the smallest groups shall be activated individually using a rapid activation algorithm.

Note all operations of dynamic grouping and group activation of the discovery sounders is not visible to the user; it is purely used as an internal facility to rapidly activate sounders. However it is useful to realise that only sounders which are configured with the same activation attribute settings can form a group facilitating faster sounder operation.

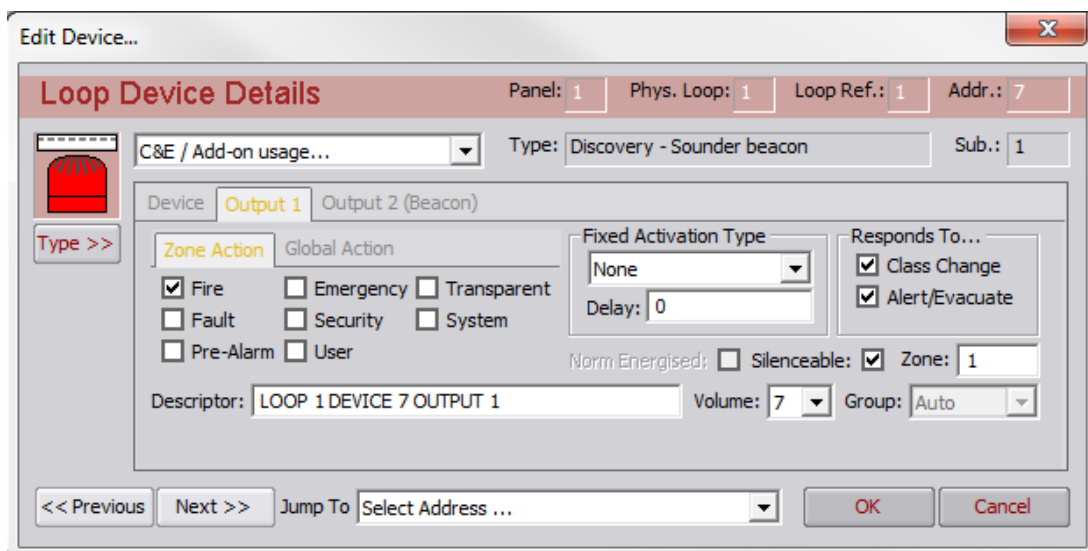

Figure 9: Discovery Sounder Beacon Device details

See Figure 7 (page 8) for an example on how the above grouping options are applied to the Discovery Sounder Beacon

Discovery Sounder Beacon (DSB) Grouping

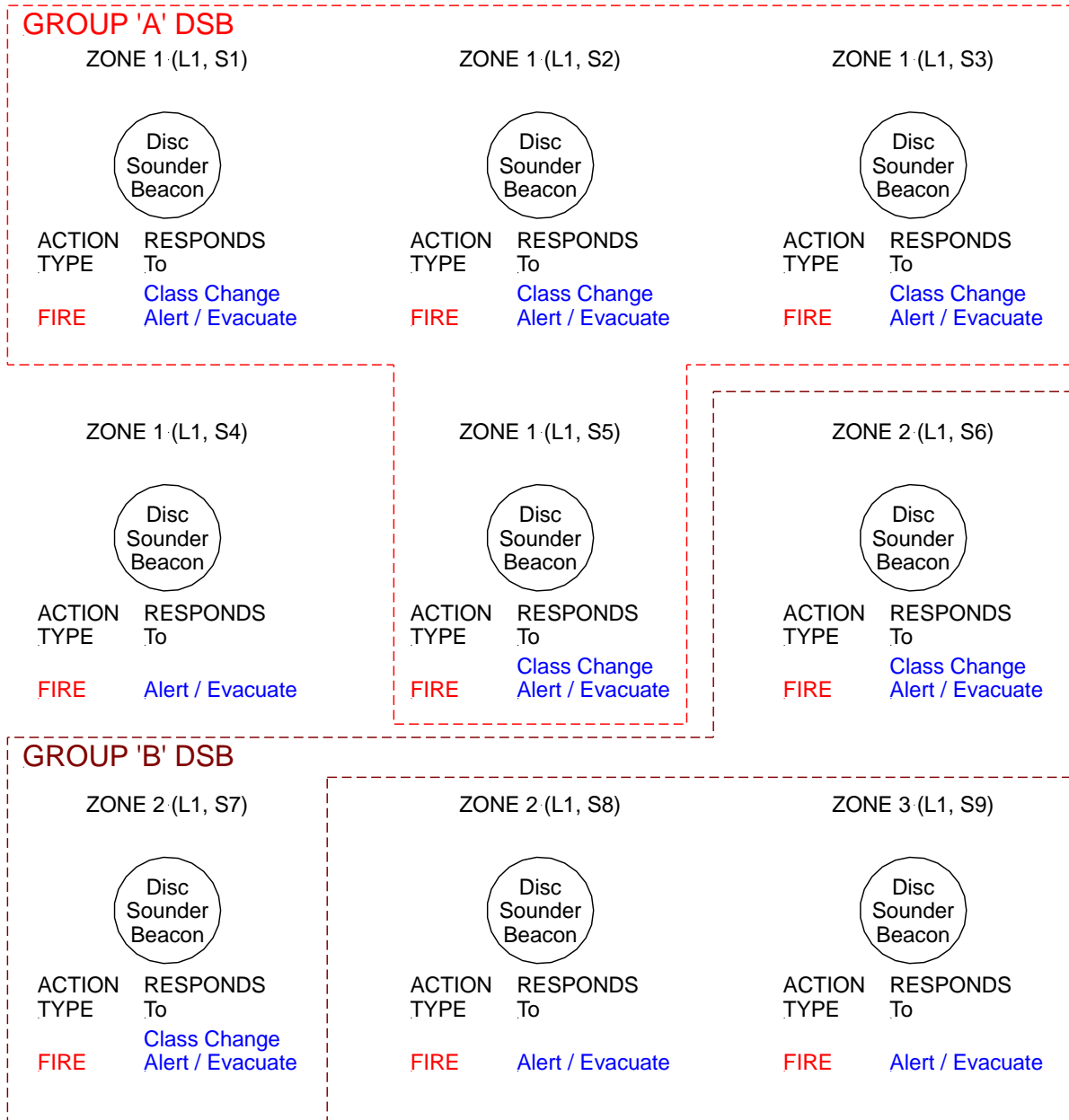

Figure 10: Discovery Sounder Beacon grouping example

3.2 Configuration Programming

Configuration programming allows the user to assign the attributes of the physical components of the system. If the configuration does not match what is physically connected to the FACP, then the FACP reports a trouble condition and details the differences. The configuration of the individual system components can be done using the PC Configuration Manager software or via on-site programming. The main configurable components of the system include:

- System
- Panel
- Loop
- Zone
- Input
- Output
- Ancillary Module
- Cause and Effects

The panel on-site programming does not support all features of the PC Configuration Manager.

The following sections list the configurable attributes for the various levels of configuration programming:

3.2.1 System Level

- Attributes are:
- Country Code
- Fire Code
- Language
- Daylight savings settings

3.2.2 Panel Level

Attributes are:

- Customer and site information
- Panel Model Number (1-2 Loop selectable)
- Day and night times: one timer per day
- Service information
- Global Alert and Evacuate tone settings
- 32 Zone LED mapping for the front board

3.2.3 Loop Level

Attributes are:

- Protocol: Apollo
- Loop termination Single-Ended or Redundant
- Sounder Group Assignments

3.2.4 Zone Level

Attributes are:

- Zone Descriptors
- Zone Activation Mode for each action type
- Configuration: Normal, Investigation, Dependency A, Dependency B, Dependency C and Alarm Verification Facility

3.2.4.1 Normal

The zone enters the fire condition immediately after receiving a fire signal from within that zone.

3.2.4.2 Investigation

This is an investigation and coincidence facility for activation of sounder and/or fire outputs.

Configurable Attributes:

- Zone Configuration: INVESTIGATION
- Investigation Delay Timeout 1: 1 – 180 seconds (default: 60 seconds)
- Investigation Delay Timeout 2: 1 – 420 seconds (default: 300 seconds)
- MCP Override: Yes / No (default: Yes)
- Inhibit Sounder Output/s: Yes / No (default: Yes)
- Inhibit Fire Output/s: Yes / No (default: Yes)

 **Note:** Only Sounder and/or Fire Output/s programmed to operate upon a global or zone fire action type are applicable for Investigation output inhibit. Fire outputs include the assigned fire outputs and ancillary outputs.

The following shall also apply:

- MCPs override the Investigation facility if configured to do so
- The EVACUATE control bypasses this Investigation facility
- (7.11.2) The Delay Mode is settable via the CONTROL>PANEL>DELAY MODE menu at access level 2 or higher
- (7.11.2) If the Delay Mode is set to ON all configured Investigation delays will be operational. If the Delay Mode is set to OFF all configured Investigation delays will be overridden i.e. any device in any zone configured with investigation delays will enter the Fire condition immediately bypassing any configured investigation delays
- The Delay Active LED shall flash when any investigation delay timer is running. The Delay LED will be illuminated ON steady when Investigation delays are configured and the Delay Mode is ON, and all investigation delay timers are not running. The Delay LED shall only be OFF if the delay mode is OFF or no investigation delays are configured or if the panel has switched to day or night mode where no delays have been configured.
- The Investigation zone configuration and associated timeouts and attributes are configurable and viewable from within the access level 3 Programming menu at the panel or via LoopMaster

3.2.4.3 Dependency A

This is a verification and coincidence facility for confirming the fire alarm condition from a fire detector.

Configurable Attributes:

- Zone Configuration: DEPENDENCY A
- Dependency Delay Timeout: 60 – 1740 seconds (default: 60 seconds)

A fire condition is raised when a confirmation fire alarm signal is received from:

- The same device re-entering alarm after the reset
- Another device from the same zone (Note: this can override the inhibit time from the first fire alarm signal)

The following shall also apply:

- MCP's bypass this Dependency facility
- The EVACUATE control bypasses this Dependency facility
- The dissipation and reset timeouts are fixed, not programmable.
- The total Dependency A Inhibit time = dissipation timeout + reset timeout = 60 seconds
- The Dependency Delay Timeout is configurable to be a minimum 1 minute and a maximum 29 minutes allowing the first alarm state to be automatically cancelled within 30 minutes of the receipt of the first alarm signal.
- The Dependency A zone configuration and associated Dependency Delay Timeout are configurable and viewable from within the access level 3 Programming menu at the panel or via LoopMaster

3.2.4.4 *Dependency B*

This is a co-incident facility for confirming the fire alarm condition from a fire detector.

Configurable Attributes:

- Zone Configuration: DEPENDENCY B
- Dependency Timeout: 300 – 1800 seconds (default: 300 seconds)

A fire condition is raised when a confirmation fire alarm signal is received from:

- Another device from the same zone
- Another device from different zone

The following also applies:

- MCP's bypasses this Dependency facility
- The EVACUATE control bypasses this Dependency facility
- The Dependency B zone configuration and associated Dependency Timeout are configurable and viewable from within the access level 3 Programming menu at the panel or via LoopMaster

Dependency B Co-sited Zone Configuration

In addition to the Dependency B functionality described above, where the confirmation fire alarm signal can come from another device from the same or different zone (i.e. any zone); the Dependency B may also be programmed such that the confirmation fire alarm signal may only come from the same zone or co-sited Dependency B zone/s.

Configurable Attributes (in addition to standard Dependency B config attributes):

- Co-Sited Group Number: 1 – 10 (default: not selected/co-sited grouping disabled)

Dependency B zones may be co-sited by assigning the same co-sited group number to each Dependency B zone that is to be co-sited with each other. The group number may be assigned in the LoopMaster ZoneManager where there is an option to accept confirmation fire alarm signals from co-sited zones or from any zone (co-sited grouping disabled).

If only one zone is assigned to a unique co-sited group number, then the confirmation fire alarm signal shall be accepted from within that zone only.

3.2.4.5 Dependency C

This is a coincidence facility for activation of sounder and/or fire outputs.

Configurable Attributes:

- Zone Configuration: DEPENDENCY C
- Inhibit Sounder Output/s: Yes / No (default: Yes)
- Inhibit Fire Output/s: Yes / No (default: Yes)



Note: Only Sounder and/or Fire Output/s programmed to operate upon a global or zone fire action type are applicable for Dependency C output inhibit. Fire outputs include the assigned fire outputs and ancillary outputs.

The configured Sounder and/or fire outputs shall not operate until the following occurs:

- A second fire signal is received from another device in any zone

The following also applies:

- MCP's do not override the Dependency C facility
- The EVACUATE control will override the Dependency C facility
- The Dependency C zone configuration and associated Dependency output types are configurable and viewable from within the access level 3 Programming menu at the panel or via LoopMaster

3.2.4.6 Alarm Verification Facility (AVF)

This is an Alarm Verification Facility for confirming a fire alarm condition from a smoke detector within a zone.

Configurable Attributes:

Zone Configuration: AVF

- Confirmation Timeout: 90 – 120 seconds (default: 120 seconds)

As the addressable analogue smoke detectors used in this system do not facilitate a physical reset of the smoke sensing circuitry within the detector; a modified algorithm supporting the fundamental requirements for alarm verification has been provided. The conventional zones supported do however support a physical reset of the conventional devices attached. Note: the conventional zones available do not distinguish between a fire signal from a smoke or non-smoke device on that zone; hence the onus is on the installer to only set the zone configuration to AVF for zones fitted with smoke detectors.

A valid fire condition is raised when a confirmation fire alarm signal is received from:

- The same device re-entering alarm during the confirmation period
- Another device within the same zone

The following shall also apply:

- The EVACUATE control bypasses this AVF facility
- Fire calling devices other than smoke detectors bypass the AVF facility (Note: conventional zones programmed with AVF are treated as smoke zones)

- Any fire signal within the AVF zone after the Confirmation period has expired shall restart the AVF algorithm

The AVF zone configuration is programmable and viewable from within the access level 3 Programming menu at the panel or via LoopMaster

3.2.5 Input Level

Attributes are:

- Device type: loop device, panel monitored input
- Action type
- Input type
- Zone number
- Alarm points (day and night)
- Pre-alarm points (day and night)
- Apollo Discovery Sensitivity (day and night)
- Latch / non latch
- Contact type
- EOL monitoring
- Local Fire (NYS4512 only)
- Input delay (pre-delay)
- Polling led

The action types supported are in order of priority are:

1. Fire,
2. Fault,
3. Pre-alarm,
4. Emergency,
5. Security,
6. User,
7. Transparent
8. System.

Within each action type there can be a number of inputs types which qualify the type of input. For example with the action type of Fire, the Input Types are Heat, Photo, Multi, Ion, Duct and MCP. When the input condition is displayed on the LCD, the action type and input type is displayed – along with other information – like time, sequence number and so forth.

3.2.6 Output Level

Attributes are:

- Type Descriptor
- Output type for panel and Add-On outputs:
 - Un-Monitored: digital output operation, not monitored for fault conditions
 - Monitored: digital output operation, monitored for fault conditions
 - Sounder: sounder output operation, monitored for fault conditions
 - Fire: Assigns output as a panel fire output and will effect the associated LED(s)
 - Fault: Assigns the output as a panel fault output and will effect the associated LED(s)
 - Ancillary: Assigns the output to effect the “Ancillary Output Disabled” LED.

Fixed activation types:

- Normal: Output responds as programmed by action or cause and effects
- Door Holder: Output will be continuously ON unless there is a mains failure or a Fire present during which time it will turn OFF.
- Reset-able: Output will be continuously ON until RESET is pressed during which time it will turn OFF for a preset period of 2 seconds before turning back ON.
- Battery Fail: Output is activated if a battery fail condition is detected.

Normally energised (Inverted activation)

Action types to respond to

Silenceable

Responds to a class change condition

Responds to an evacuate/alert condition

Zone number

Sounder Group Settings

Volume setting for Hochiki

Description string

Activation delay

3.3 On Site Programming / Auto learn.

 Cause and effect programming is not available via on-site programming.

 **Note:** “On-site” programming only allows the following to be set

- Set date and time
- With sensors: set descriptor, action type and input type, alarm threshold (day and night), zone number, verification, investigation facility, delays, pre-alarm
- With inputs: set descriptor, action type and input type, zone number, monitoring, polarity, latching, pre-delay
- With outputs: activation condition, activation patterns (for each condition), silence-ability (for each condition), post delay, supervision
- Passwords
- Day and night
- Auto learn (Network wide)

The panel also supports Auto Learn and the ability to resolve configuration conflicts.

3.4 Software Download

The software supports a remote FACP facility, where an image of the front panel of the FACP is available via the configuration software and full control and feedback from the FACP is available. This facility is secured by the use of a password.

The software supports a data connection to the FACP for the following purposes:

- Downloading the boot-loader software from the configuration software to the FACP
- Downloading application software from the configuration software to the FACP
- Downloading configurations from the configuration software to the FACP
- Uploading configurations from the FACP to the configuration software
- Uploading event log. The event log is stored in a format that is suitable to be viewed by programs such as MICROSOFT EXCEL.
- Exchanging commands and data as necessary to support the remote FACP operator interface

The data connection is via a direct serial connection or modem (both landline and wireless). A USB data connection is also supported. The speed of the data connection has been set to keep downloads and uploads to a “reasonable” time. A “reasonable” time is considered to be 5 minutes or less and as a result of this the information is compressed prior to transmission, and uncompressed at the receiving end. Uploads and downloads also contain error detection to prevent “corrupt” data from being stored.

4 General Overview

4.1 The Main Screen

The main screen consists of the following;



Note: The header displays the version of software, its application and the name given to the project in the opening screen.

Main menu Main toolbar Tree view Tree view toolbar Details panel Details toolbar

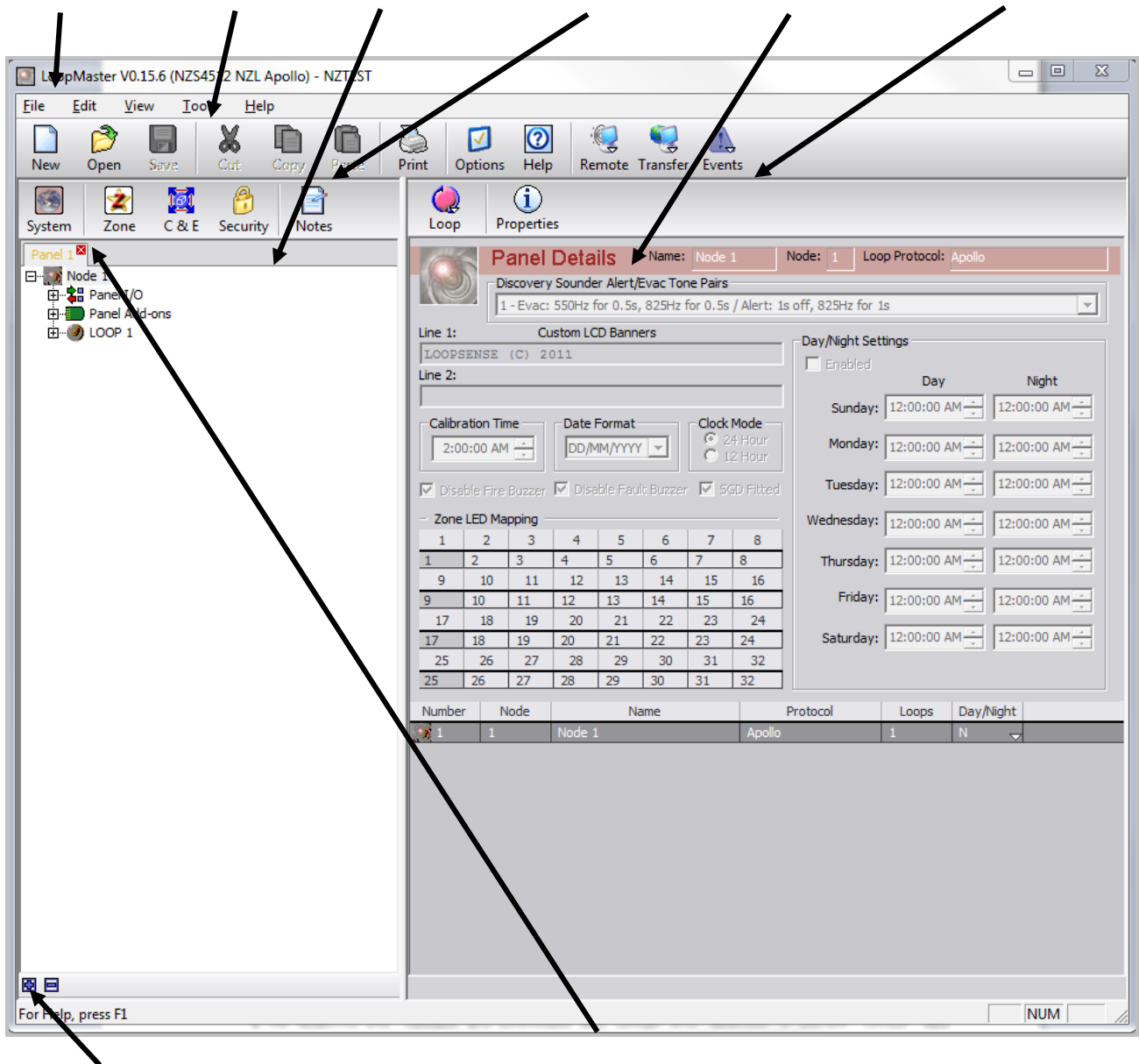

**Expand / Collapse the Tree View
two or more panels are active)**

Click to remove a panel (Future networking option only active if

5 Top Level (Main) Functionality

5.1 Introduction

This section introduces the top-level functionality accessible via the main menu and main toolbar.

We will first look at the main menu and its component entries and then follow that with the main toolbar and its component buttons. Finally, we will look at the operations and/or dialog boxes that appear as a function of the menu items and toolbar buttons.

5.2 The Main Menu

5.2.1 File Menu

In the “Main Menu” click on File. The following dropdown box will be presented.

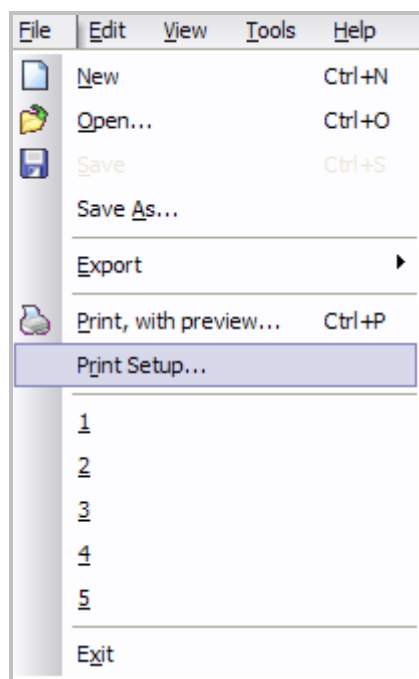

NEW:	Clears the current project and creates a new one
OPEN:	Opens a previously saved configuration file for editing
SAVE:	Saves the current configuration to disk
SAVE AS:	Saves the current configuration with a different name
EXPORT:	Exports the current configuration to disk
PRINT, WITH PREVIEW:	Sends the current configuration to a printer
PRINT SETUP:	Setup a printer’s parameters
<u>1</u>, <u>2</u>, <u>3</u>, <u>4</u> and <u>5</u>:	Most recently used file list
EXIT:	Close the application

5.2.2 Export Menu

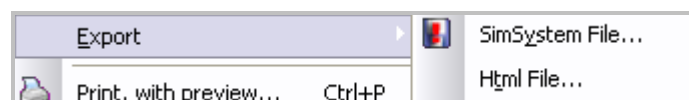

SimSystem File exports the current configuration to a SimSystem compatible (.ASY) file that can then be loaded and simulated via an Apollo SimSystem loop emulator while selecting the **Html File** exports the current configuration to a Html File.

5.2.3 Edit Menu

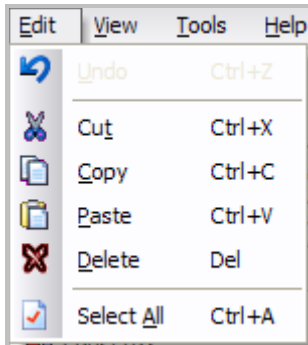

The items in the edit menu are available for use only when they are highlighted. Their availability and functionality can, and will, change depending on the current context the application is in.

UNDO: This selection will 'undo' the last operation performed.

CUT: A selected area will be copied to the clipboard and then deleted

COPY: A selected area will be copied to the clipboard

PASTE: Data from the clipboard will be pasted to the current selection

DELETE: A selected area will be deleted

SELECT ALL: Select all of the selectable objects

5.2.4 View Menu

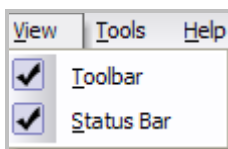

TOOLBAR: Show or hide the main toolbar

STATUS BAR: Show or hide the main status bar

5.2.5 Tools Menu

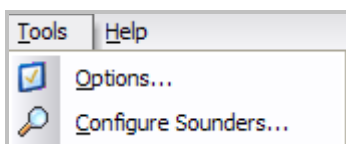

OPTIONS: Opens the 'Options' dialog box, allowing the user to edit various application settings

CONFIGURE SOUNDEERS: Configure Sounders for global actions

5.2.6 Help Menu

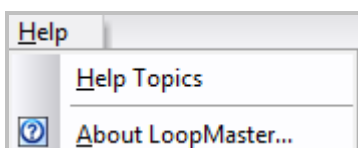

HELP TOPICS: Opens the Help window and shows the table of contents

ABOUT LOOPMASTER: Opens the 'About' box, with various details about the application

5.3 The Main Toolbar



Clears the current project and creates a new workspace (see File Menu)



Opens a previously saved configuration file for editing (see File Menu)



Saves the current configuration to disk (see File Menu)



The selected area will be copied to the clipboard and then deleted (see Edit Menu)



The selected area will be copied to the clipboard (see Edit Menu)



Data from the clipboard will be copied to the current selection (see Edit Menu)



Send the current configuration to a printer (see File Menu)



Opens the 'Options' dialog box, allowing the user to edit various application settings



Opens the Help window and shows the table of contents



Displays a drop down menu containing a list of available connections that can be used for remotely controlling a panel.



Displays a drop-menu containing a list of available connections that can be used for transferring files to or from a panel



Displays a drop-menu containing a list of available connections for receiving the events log from a panel

5.4 Derived Functionality

This section illustrates the result of selecting one of the items from the main menu or toolbar, as described in the sections above.

5.4.1 Open

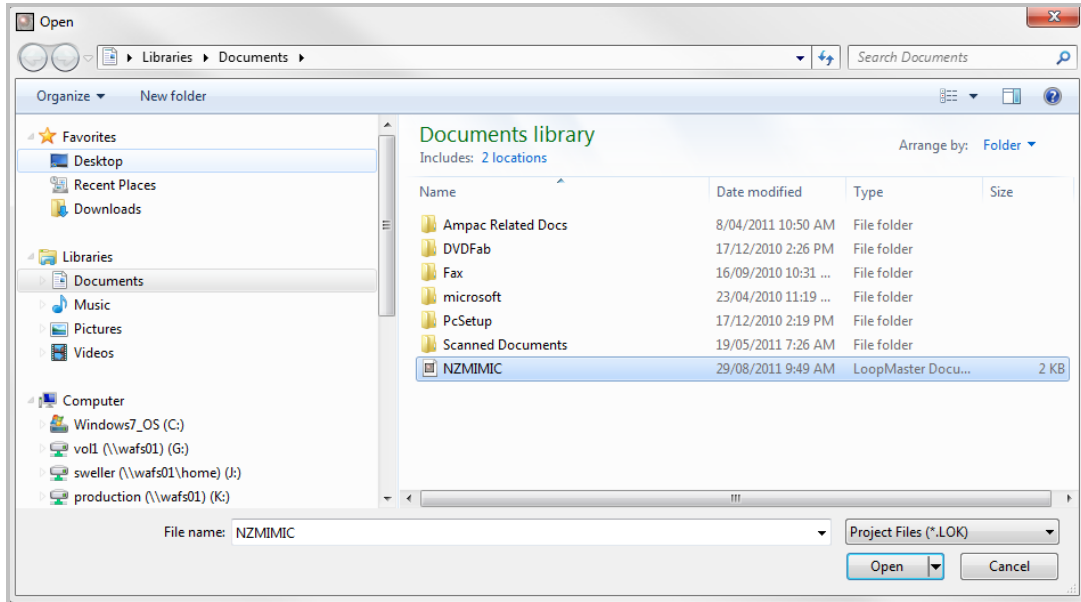

Figure 11: Open Window

This is the dialog box that is opened by the Windows operating system to allow the user to select a file to open (load). Normal Windows file navigation and selection rules apply.

5.4.2 Save As

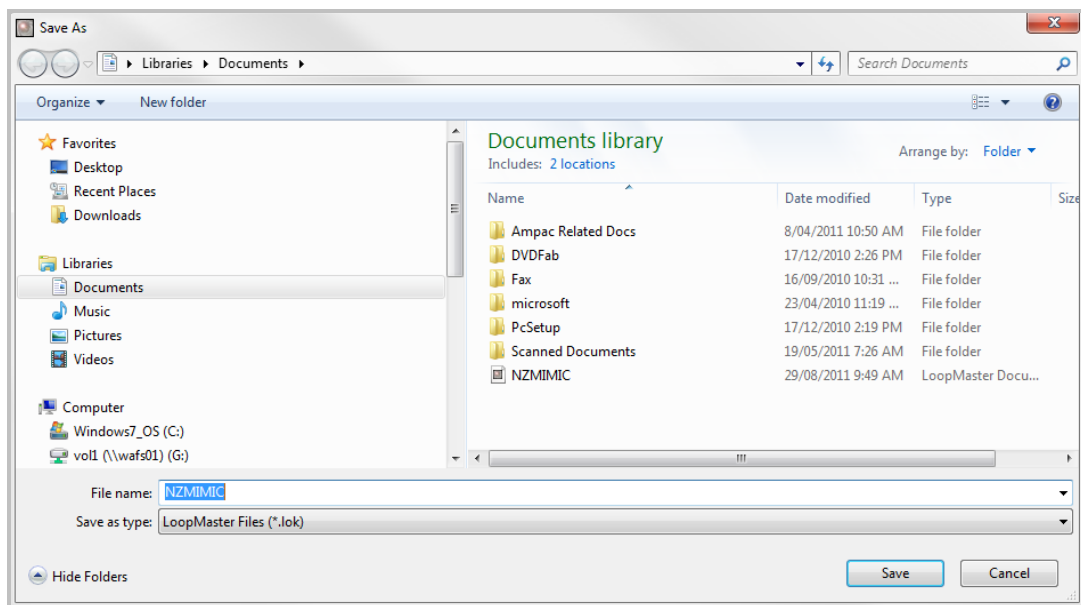

Figure 12: Save As Window

This dialog box is opened by the Windows operating system to allow the user to either select a file to save the current configuration data to or to specify the name of a new file that the current configuration data will be saved to. Normal Windows file navigation and selection rules apply.

5.4.3 Export / Select Loop



Figure 13: Export / Select Loop Window

This dialog box allows the user to select which loops will be used to create the SimSystem or Html file.

The left column shows the available loops (and their 'checked' status) while the right column indicates only those loops selected for export.



Note: *That due to Apollo SimSystem file limitations, a maximum of 8 loops can be selected in any file export operation and will be numbered from 1 to 8 in the SimSystem file, according to their selection order in this dialog box. As such, their numbering in the SimSystem file may not coincide with their numbering in the configuration data.*

Click 'OK' to continue with the export operation.

Click 'Cancel' to quit the export operation and return to the application.

5.4.4 Save SimSystem File

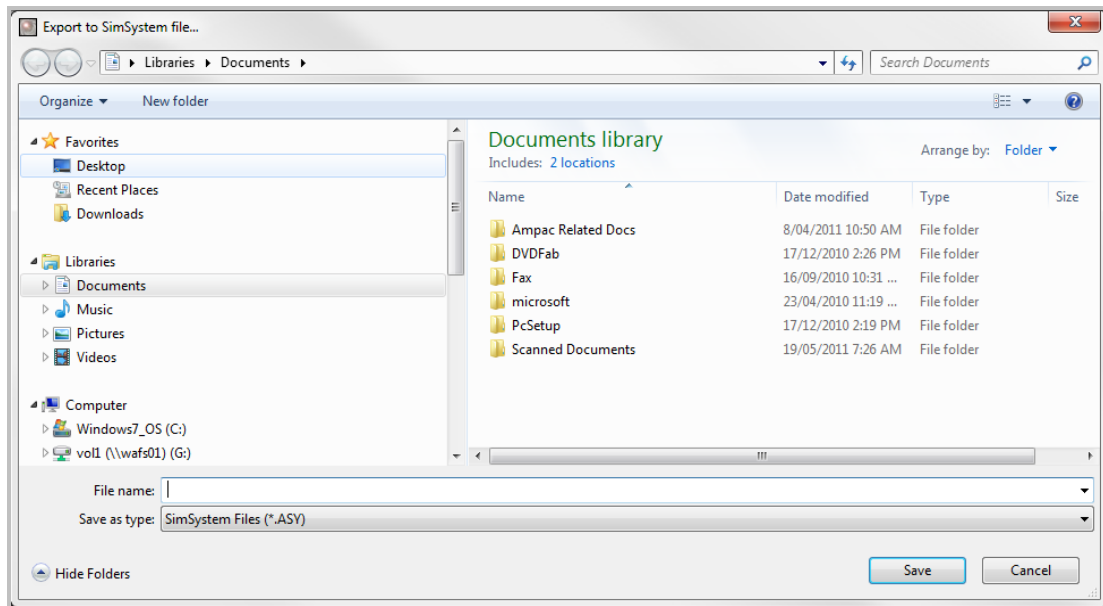

Figure 14: SimSystem File Save Window

This dialog box is opened by the Windows operating system to allow the user to select a file to export the selected loops to *or* to specify the name of a new file that the selected loops will be exported to.

The default file extension for an Apollo SimSystem file is .ASY or Html for formatted files.

Normal Windows file navigation and selection rules apply.

5.4.5 Print Setup

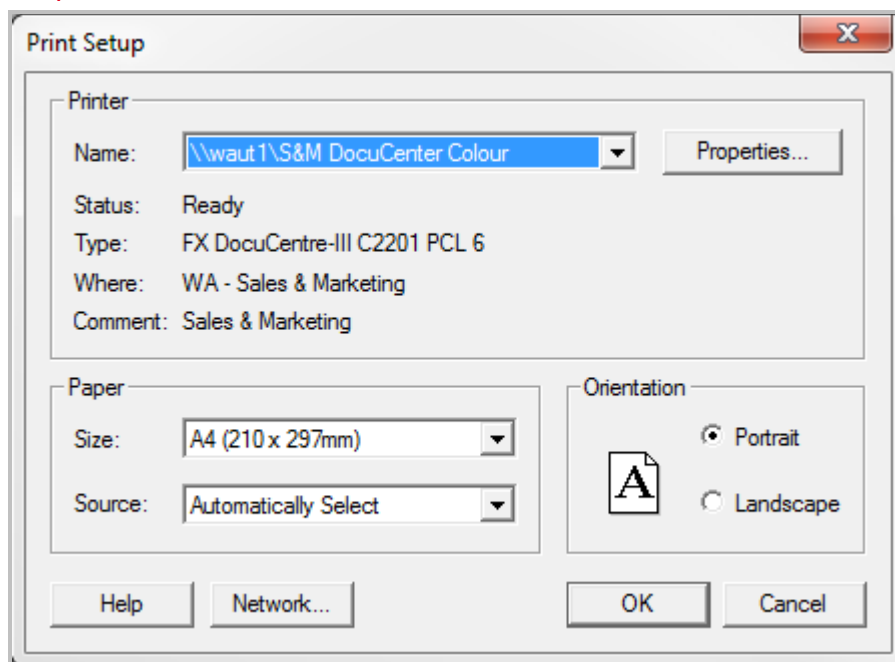

Figure 15: Print Setup Window

The Print Setup dialog box is opened by the Windows operating system to allow the user to setup printer characteristics prior to printing.

5.4.6 Print with Preview

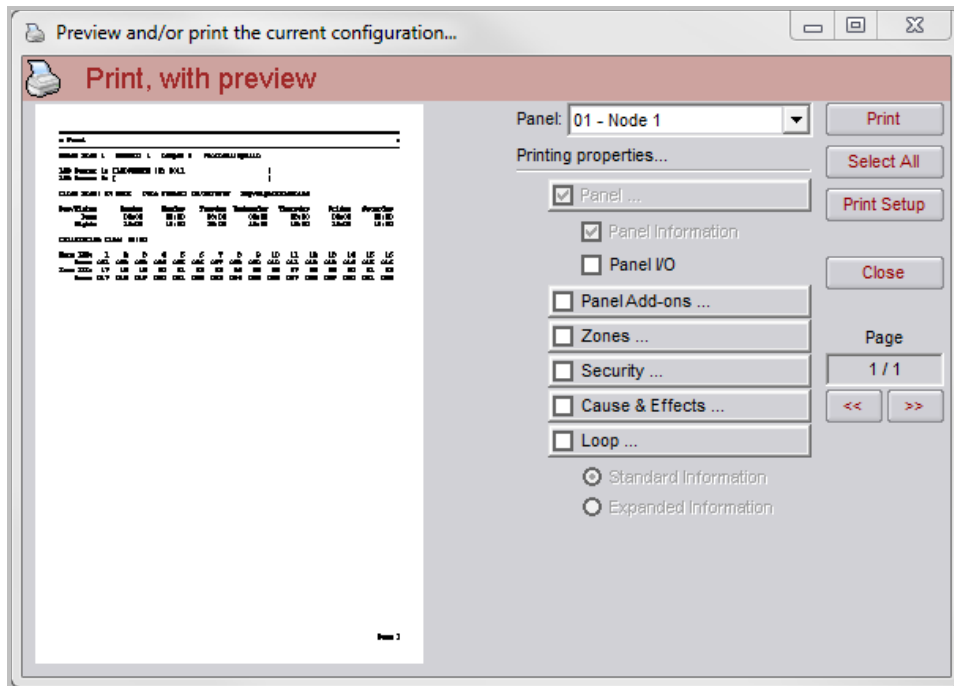



Figure 16: Print with Preview

The purpose of this dialog box is to allow the user to perform the following:

- Using the Panel drop-down box the user can select which panel will be used for both the preview and the print. This way the user can print out information for one panel at a time.
- Below the Panel drop-down box is a set of checkboxes labelled 'Printing properties', which allows the user to select what is to be previewed and, subsequently, printed. Note that Panel Information is always selected by default and cannot be de-selected.
- The Loop checkbox allows two modes of operation: Standard (the entire loop is previewed/printed on a device level) and Expanded (the entire loop is previewed/printed with all I/O fully expanded)
- The Select All button will select all the checkboxes, as mentioned above.
- Via the large, white preview box to the left the user can preview how the print will appear on real paper. By clicking on the '<<' and '>>' buttons the user can go backwards and forwards through pages and preview each in turn. Above these buttons is text to show which page the user is currently previewing and the total number of pages; i.e. current page / total pages.
- The Print button will open the Windows operating system Print dialog box, to allow the user to select which printer to send the print to and then to actually initiate the print.
- The Print Setup button will open the Windows operating system Print Setup dialog box, to allow the user to setup the printer with user-defined settings.
- The Close button will close the Print with Preview dialog box and return to the application. If a print has been initiated, via the Print button, closing this dialog box will not terminate the print job.

 **Note:** *Print and Print preview is an extremely useful tool when structuring a project or fault finding. By selecting, hence viewing, a particular "Printing Property" the installation or project, can be checked against the design criteria.*

5.4.7 Select All

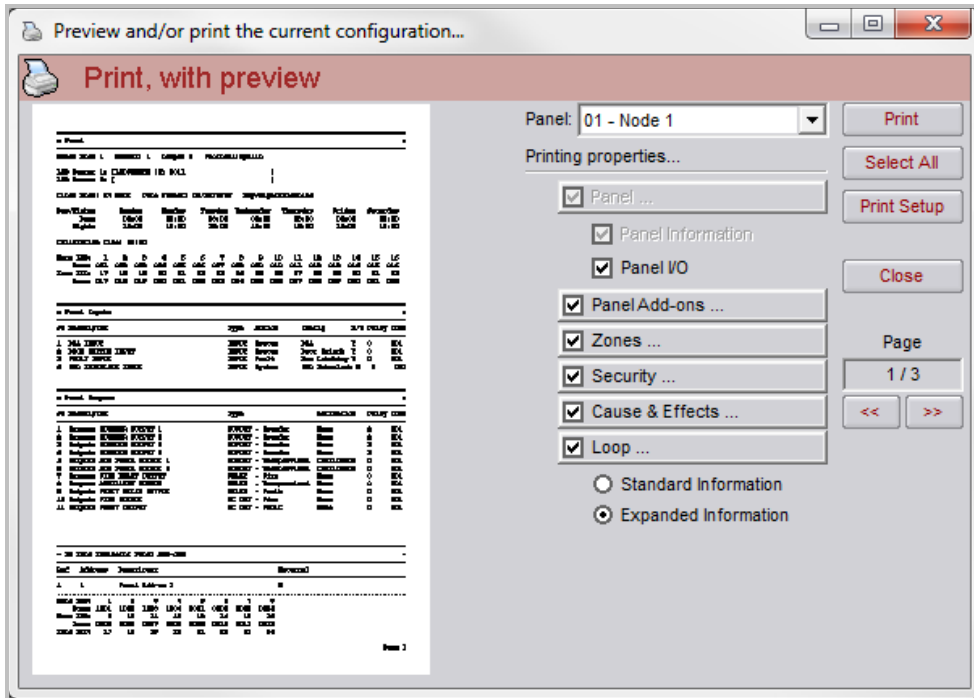

Figure 17: Preview Window

The above shows the Print with Preview dialog box with all checkboxes selected following the user clicking on the Select All button.

Note: that now we have 3 pages in total as we are displaying more information: the number of pages will vary depending on the size and complexity of the current configuration.

5.4.8 Print

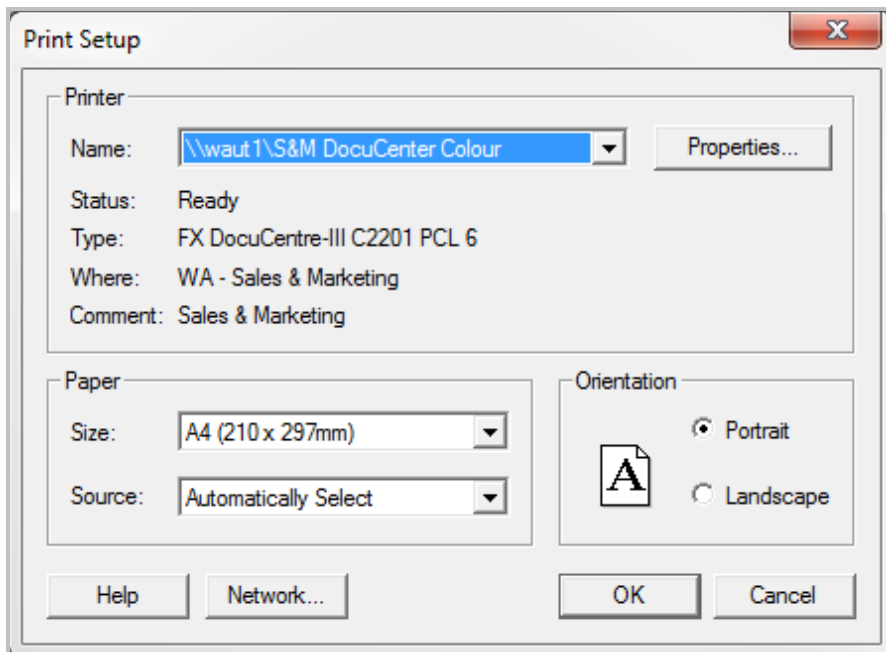

Figure 18: Printer Setup Window

Having selected the information to be printed in the “Print Preview” screen click on “Print” to open the Print screen. This is a Windows operating system dialog box to allow the user to select which printer to print to and to set the properties for that printer. Clicking ‘OK’ will initiate the print job.

5.4.9 Application Colours

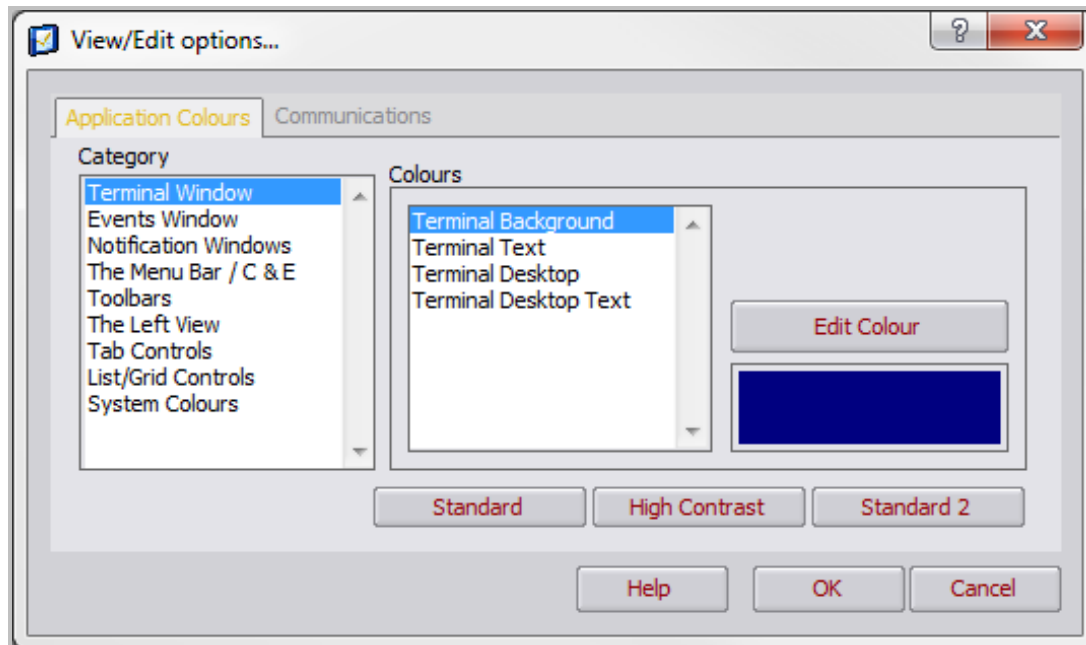

Figure 19: Options Window

The Options dialog box allows the editing of every colour in the application. The chosen colours are stored in the system registry and are available the next time the application is opened.

There are 3 buttons - Standard, High Contrast and Standard 2 - these are selectable inbuilt colour schemes. The High Contrast scheme makes every background white and most text black.

Colours

The colours window is made up of a Category list, a sub-category list and a current colour representation:

- The category list contains the list of application elements which allow colour editing
- The sub-category list contains the actual specific application entities of the category type and it is these colours that are edited
- The block of colour below the Edit Colour button represents the current colour associated with the currently selected sub-category selection. Clicking on the Edit Colour button will open a colour editing dialog box
- The “Standard” button will restore all category and sub-category colours to their default settings, which are defined at application compile-time.

Restricted Palette

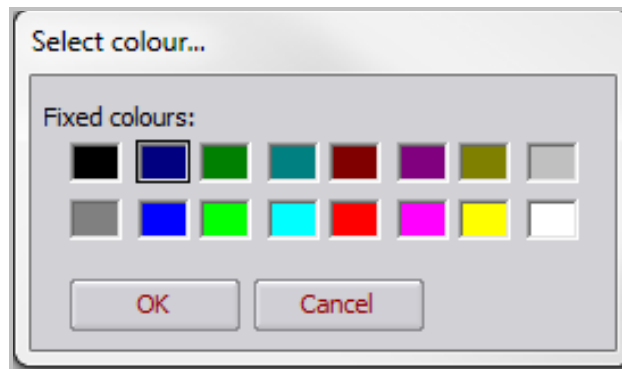

Figure 20: Restricted Palette Colours Window

For those entities that only allow a selection from a 16 colour palette, clicking on the Edit Colour button will open this dialog box. To select the desired colour the user needs to only click on the appropriately coloured box.

Full Palette

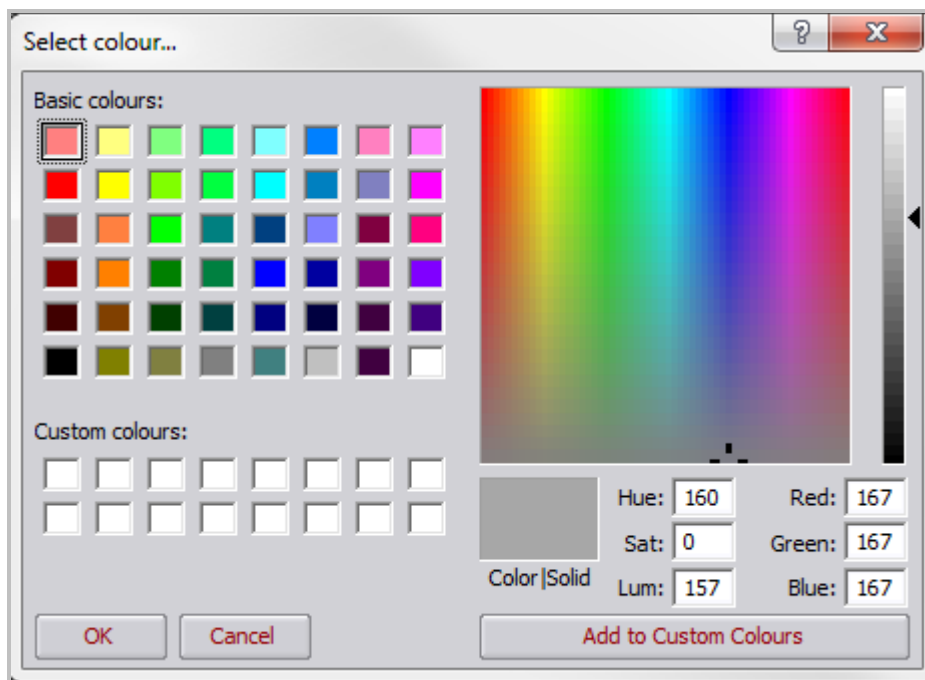

Figure 21: Full Palette Colours Window

For those entities that allow the full range of 24-bit colour selection, clicking on the Edit Colour button will open this dialog box. To select the desired colour the user needs to only click on the appropriately coloured box or select from the colours to the right.

5.4.10 Communications

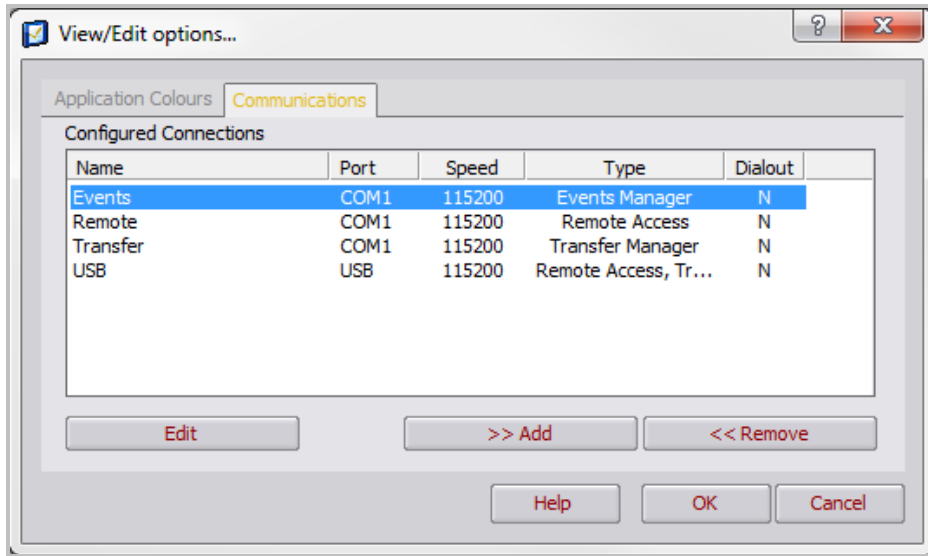

Figure 22: Communication Window

The ‘Communications’ dialog box is made up of the ‘Configured Connections’ list, an Edit button, an Add button and a Remove button:

- The ‘Configured Connections’ list shows the list of communication ‘connections’ already added by the user and located in the system registry. All relevant information required to properly locate the required connection is displayed; i.e. Name, Port No. (com port) or “USB” designation, Speed (baud rate), Type (see below) and whether this is a ‘dialout’ connection
- To edit a connection the user can either double-click on a connection in the list or click on the Edit button (to edit the currently highlighted connection in the list)
- To add a connection the user simply has to click on the ‘Add’ button (see below). A maximum of 16 connections can be added.
- The removal of a connection involves firstly selecting the connection to be removed and then clicking on the ‘Remove’ button

Editing & Communications Settings

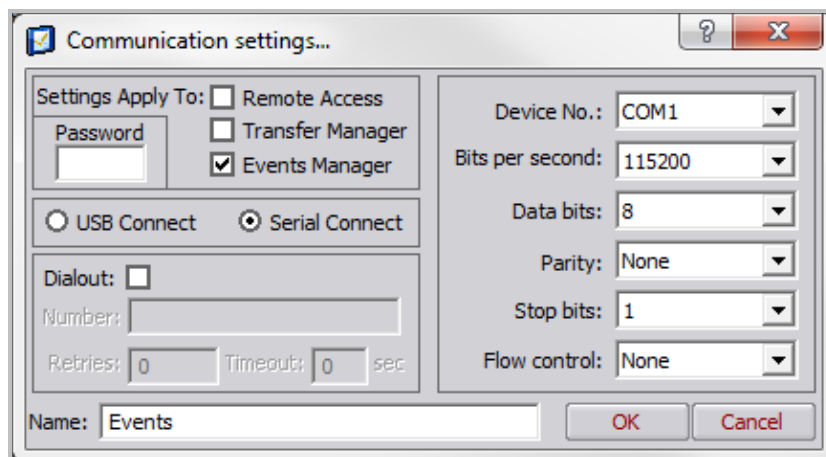
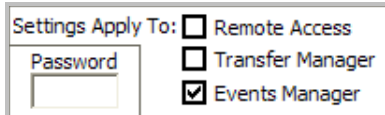

Figure 23: Communication Stetting Window

This dialog box is displayed following the user performing at least one of the following operations on the Communications window, as described above:

- Double-clicking on an existing connection in the list
- Selecting a connection in the list and then clicking on the Edit button
- Clicking on the Add button and the number of maximum allowable connections has not been reached

Setting the Connection Type and Password



The user is able to select the desired connection type this connection will apply to and is able to select either one or multiple connections types, those being ‘Remote Access’, ‘Transfer Manager’ or ‘Events Manager’.

Each connection allows the user to specify a password to be used when accessing a panel remotely. This password can be dynamically changed should a user decide to do so when attempting a connection to a panel and receiving a ‘Password Error’ message.

Selecting the USB or Port / Device No

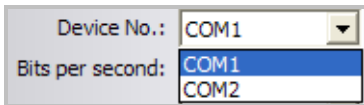

The user selects the appropriate communications port from the drop list.

This is only editable if the user has selected the ‘Serial Connect’ and NOT selected the ‘USB Connect’ radio button.

This drop list is populated with the communications ports as detected by both the Windows operating system and the application. These can be hardware communications devices or software/emulated ports. This will cover most, if not all, RS232 and USB devices, including USB-to-serial converters.



Note: *The default setting is **COM1**.*

Selecting the Baud Rate

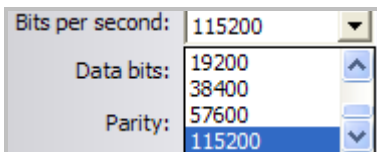

The drop list displays the selectable serial baud rates available for the current connection; i.e. 110, 300, 1200, 2400, 4800, 9600, 19200, 38400, 57600 or 115200. This is only editable if the user has selected the ‘Serial Connect’ and NOT selected the ‘USB Connect’ radio button.



Note: *The default setting is **115200bps**.*

Selecting the Data Bits

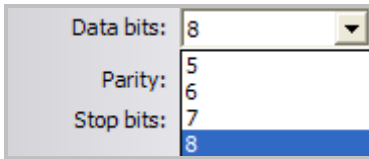

The screenshot shows a dropdown menu for 'Data bits'. The menu is open, displaying the following options: 5, 6, 7, and 8. The option '8' is currently selected and highlighted in blue.

This drop list displays all the available data bit settings, allowing the user to select one for the current connection; i.e. 5, 6, 7 or 8. This is only editable if the user has selected the 'Serial Connect' and NOT selected the 'USB Connect' radio button.



Note: The default setting is **8 data bits**.

Selecting the Parity

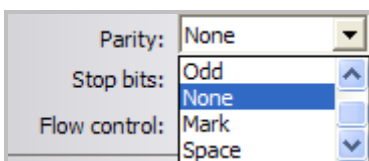

The screenshot shows a dropdown menu for 'Parity'. The menu is open, displaying the following options: None, Odd, and Space. The option 'None' is currently selected and highlighted in blue.

This drop list displays all the available parity settings, allowing the user to select one for the current connection; i.e. Even, Odd, None, Mark or Space. This is only editable if the user has selected the 'Serial Connect' and NOT selected the 'USB Connect' radio button.



Note: The default setting is **None**.

Selecting the Stop Bits

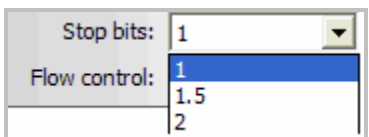

The screenshot shows a dropdown menu for 'Stop bits'. The menu is open, displaying the following options: 1, 1.5, and 2. The option '1' is currently selected and highlighted in blue.

This list displays the available stop bit settings, allowing the user to select one for the current connection; i.e. 1, 1.5 or 2. This is only editable if the user has selected the 'Serial Connect' and NOT selected the 'USB Connect' radio button.



Note: The default setting is **1 stop bit**.

Selecting the Flow Control

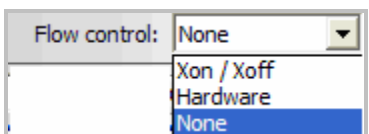

The screenshot shows a dropdown menu for 'Flow control'. The menu is open, displaying the following options: None, Xon / Xoff, Hardware, and None. The option 'None' is currently selected and highlighted in blue.

This list displays all the available flow control settings, allowing the user to select one for the current connection; i.e. Xon / Xoff, Hardware or None. This is only editable if the user has selected the 'Serial Connect' and NOT selected the 'USB Connect' radio button.



Note: The default setting is **None**.

5.5 Events

The Menu

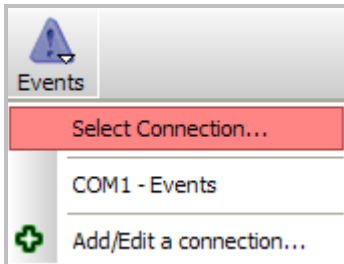

Clicking on the 'Events' button in the main toolbar displays a connection menu, listing the connections that can be used to host an Events session. Each connection is listed with its communications port and user-defined connection name. View, Adding or Editing a connection can also be selected from this drop down box

An Events session will begin once the user has selected a connection from the menu.

The Events session is used, primarily, to receive the events log (a series of specific events stored within the attached panel's flash memory) from the attached panel. It can be *printed*, *saved* to a text file or simply *viewed* within the included, multi-coloured, list control while at the same time it can also be saved to a HTML file which can be loaded into Excel preserving formatting and colours.

Operation

The Events window consists of a large, multi-column, multi-coloured, list control holding all the events received from a panel. All information necessary for pin-pointing a specific event is included.

The events may be sorted according to specific column data by clicking on the respective column. The current sort column will be highlighted via an arrow chevron in the respective column header.

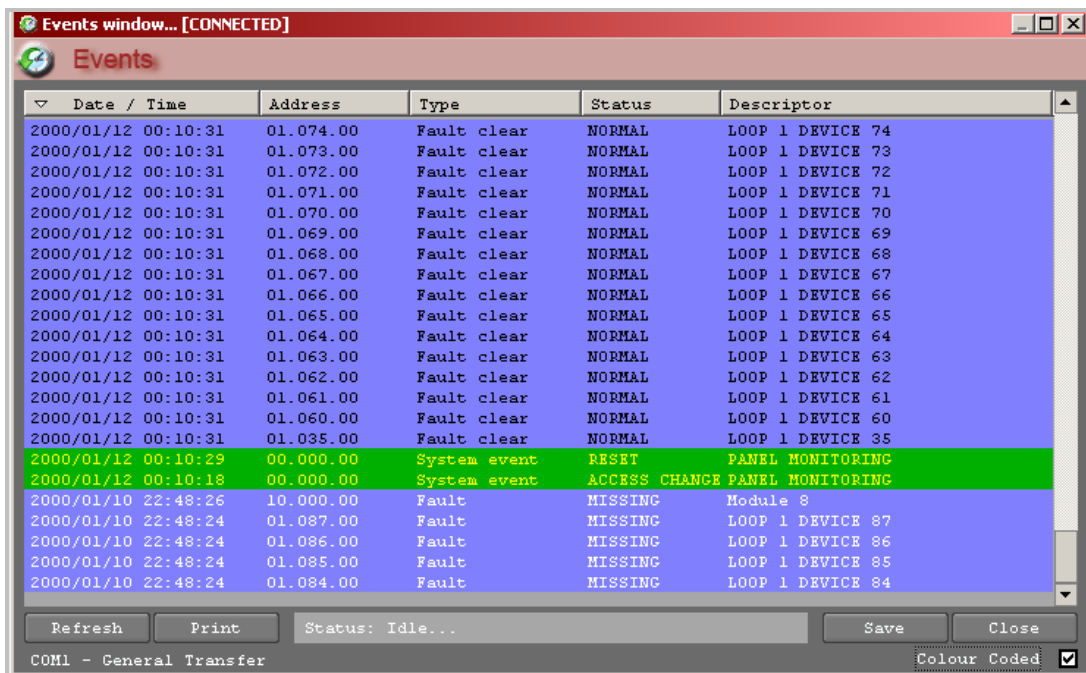

Figure 24: Events Window

From this window the user may either:

- Refresh: Clicking this button will cause the currently displayed events to be cleared from the list control and refilled from the attached panel,
- Print: Clicking on 'Print' allows the user to send the currently displayed events to an attached printer,
- Save: Clicking 'Save' allows the user to send the currently displayed events to a specified text or Html file, for archival purposes. Note that the colouring is not saved in the text file,
- Close: This simply closes the Events window,
- Colour Coded: This checkbox toggles between colour-coded and black-and-white mode; i.e. either displays the multi-coloured list control or a black text on white background list control.

The following available colours are assigned as such:

UNKNOWN:	bgcolor = 0x008B8B8B;	fgcolor = 0x00FFFFFF;	TEST
UNKNOWN RESTORE:	bgcolor = 0x008B8B8B;	fgcolor = 0x00000000;	TEST
FIRE:	bgcolor = 0x000000FF;	fgcolor = 0x0080FFFF;	TEST
FIRE RESTORE:	bgcolor = 0x000000FF;	fgcolor = 0x00000000;	TEST
FAULT:	bgcolor = 0x00FF8080;	fgcolor = 0x00FFFFFF;	TEST
FAULT RESTORE:	bgcolor = 0x00FF8080;	fgcolor = 0x00000000;	TEST
PRE-ALARM:	bgcolor = 0x000000AF;	fgcolor = 0x0000EEEE;	TEST
PRE-ALARM RESTORE:	bgcolor = 0x000000AF;	fgcolor = 0x00000000;	TEST
EMERGENCY:	bgcolor = 0x00FF00FF;	fgcolor = 0x00FFFFFF;	TEST
EMERGENCY RESTORE:	bgcolor = 0x00FF00FF;	fgcolor = 0x00000000;	TEST
SECURITY:	bgcolor = 0x009F9F00;	fgcolor = 0x00FFFF00;	TEST
SECURITY RESTORE:	bgcolor = 0x009F9F00;	fgcolor = 0x00000000;	TEST
USER:	bgcolor = 0x00DDDDDD;	fgcolor = 0x00008800;	TEST
USER RESTORE:	bgcolor = 0x00DDDDDD;	fgcolor = 0x00000000;	TEST
SYSTEM:	bgcolor = 0x0000B000;	fgcolor = 0x0000FFFF;	TEST
SYSTEM RESTORE:	bgcolor = 0x0000B000;	fgcolor = 0x00000000;	TEST
DISABLE:	bgcolor = 0x0000FFFF;	fgcolor = 0x00808080;	TEST
DISABLE RESTORE:	bgcolor = 0x0000FFFF;	fgcolor = 0x00000000;	TEST

Figure 25 Default colour selection

 **Note:** Note that in the above, bgcolor is the background colour, represented in BGR (blue/green/red) format and fgcolor is the foreground colour, represented in BGR (blue/green/red) format.

Save

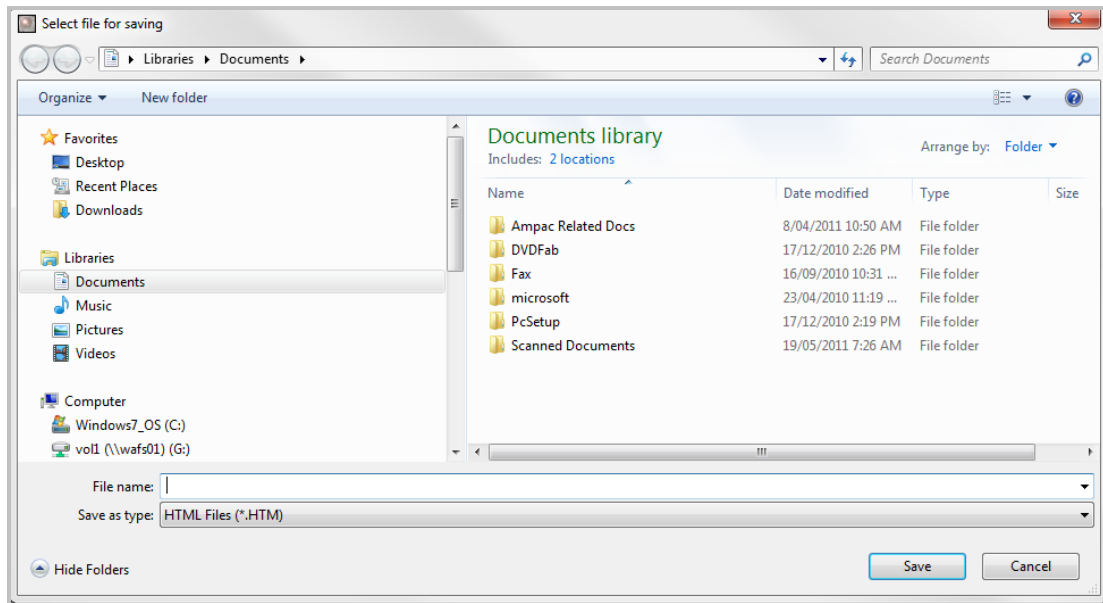

Figure 26: Event Window Save

The dialog box is opened when the user clicks on the ‘Save’ button in the “Events” window, and allows the user to select (or create) a text or Html file to receive the event data.

Colour Coding

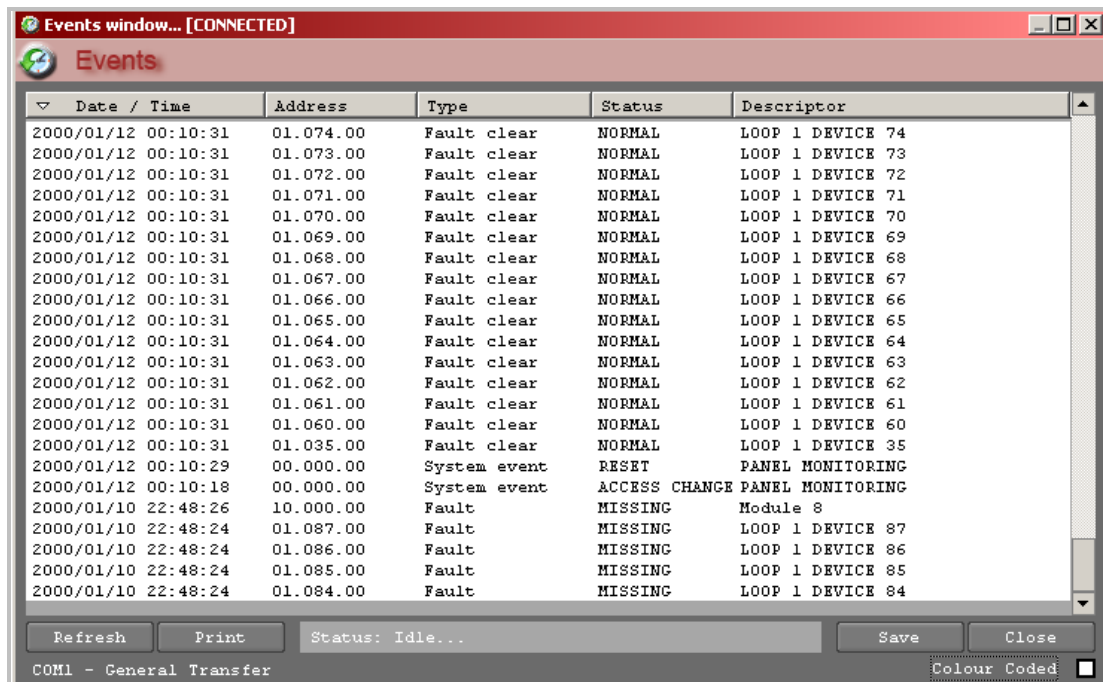

Figure 27: Colour Coded Operation

De-selecting the ‘Colour Coded’ checkbox causes the Events window to display the events list as black text on a white background.



Note: Note that the ‘Colour Coded’ checkbox also affects the way the events are printed; i.e. with the checkbox checked the default printout includes the colour scheme, otherwise the printout becomes black on white.

6 Sub Level (Tree & Details Pane) Generic Functionality

The Tree View provides the key method for constructing and editing a specific configuration. It allows the user to navigate through a configuration, in a graphical manner, and to easily and quickly select entities for editing.

The companion to the Tree View is the Details Pane, which reflects the currently selected item in the Tree View. That is, the Details Pane will always show relevant data directly related to the item currently highlighted in the Tree View.

6.1 The Tree View Toolbar

The Tree View toolbar resides at the top of the Tree View window and provides quick access, via toolbar buttons, to configuration-wide configuration parameters; i.e. it provides access to editing options for configuration elements that are not bound to a specific panel.



Figure 28: The Tree View Toolbar



Clicking on the 'System' button opens the System Settings dialog box.

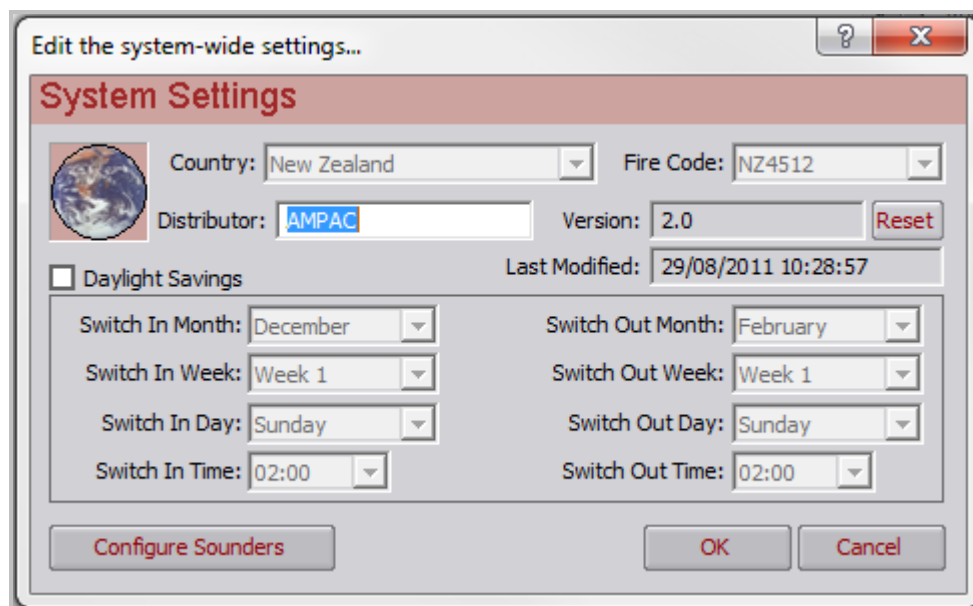

Figure 29: System Setting Window

The System Settings dialog box allows the user to edit system-wide configuration parameters i.e. parameters that are not panel specific, but can be applied across an entire network, if required. The System Settings dialog box provides the following editing options:

Country / Fire Code: Displays the country the configuration is intended for and is linked and restricted by the Fire Code. These items are not editable.

Distributor: Allows for some user-defined text to represent the panel distributor.

Version: Displays the current version number of the configuration and allows the user to reset its value,

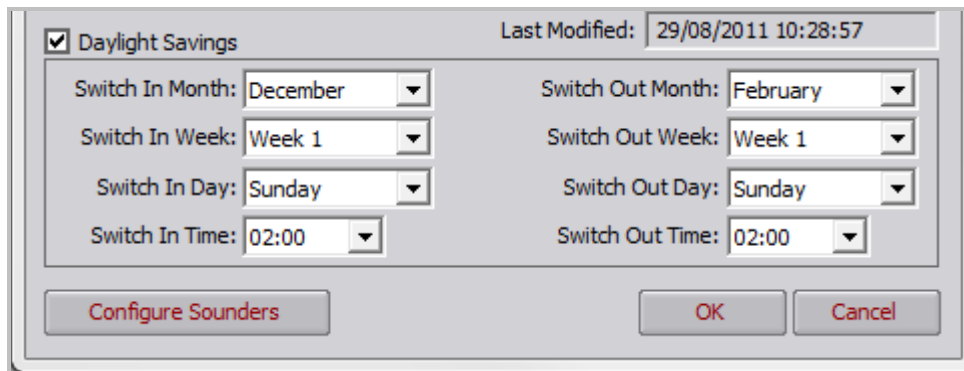

Figure 30: Daylight Saving Window

Daylight Savings: This checkbox either allows or disallows the setting of daylight savings parameters for notifying the panel on which dates and times daylight savings compensation should begin and end. To enable left click on the “Daylight Savings” check box.

Switch-In / Switch-Out Month, Week, Day and Time

Provides the user with the ability to select the month, week, day and time in which daylight savings is to commence /cease via the drop down boxes.

Configuring Sounders

Select the mode of operation.

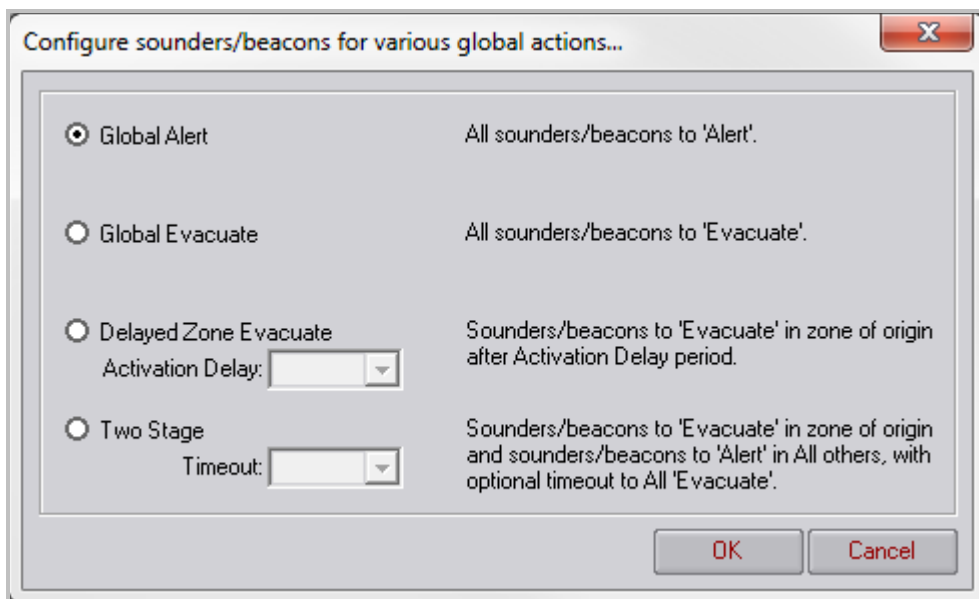
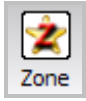

Figure 31: Sounder Beacon Setup

6.2 Zone Manager



Clicking on the 'Zone' button opens the Zone Manager dialog box.

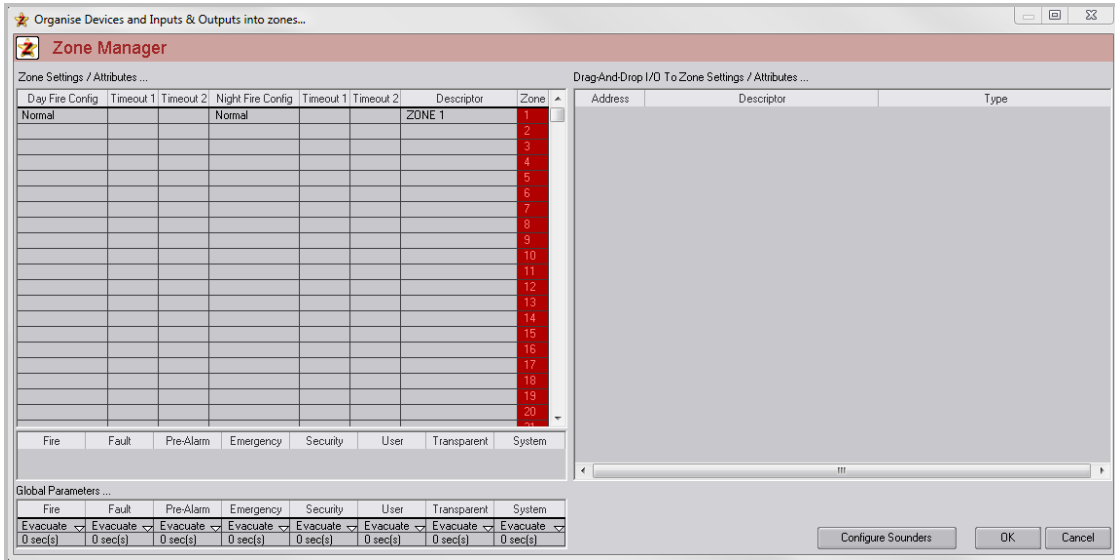

Figure 32: Zone Manager Window

The Zone Manager dialog box is primarily used to edit zone-specific parameters and move various inputs and outputs across different zones.

The Zone Manager consists of 4 distinct areas:

1. The Zone Settings/Attributes Window: This is the largest window (at the top-left) and holds all the information for a specific zone, as defined by the 'Zone' column. Each column has a unique column header notifying the user as to its purpose. Besides the Zone column, all other column entries are editable,
2. The Zone Parameters Window: Directly below the Settings/Attributes Window, this window holds the editable settings for all the action types available to a zone,
3. The I/O to Zone Settings / Attributes List Window: To the right of the Settings/Attributes Window, this window displays all of the available (zone-able) inputs and outputs currently defined in the current configuration for the currently selected zone number in the Settings/Attributes window. As defined in the proceeding sections, these inputs and outputs can be selected and drag-and-dropped across zones.
4. The Global Parameters Window: The final window, at the bottom of the Zone Manager dialog box, this windows holds the editable settings for all the action types available globally; i.e. the global zone.

Zone Selection

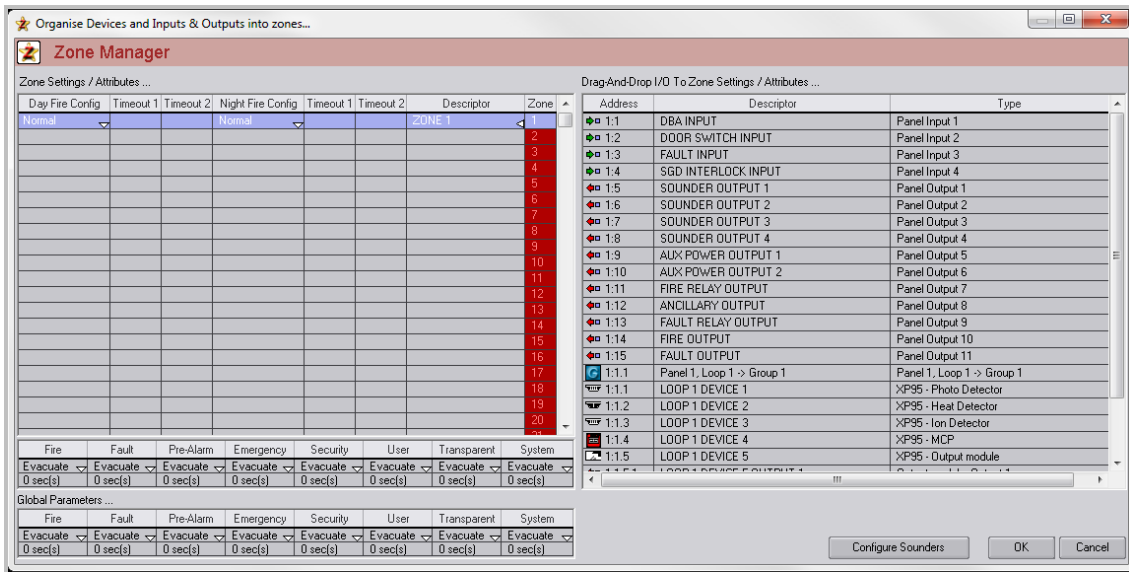

Figure 33: Zone Manager Zone Selection

The above shows an example display upon the user selecting Zone 1, which has a number of inputs and outputs available to it.



Note: The down and left pointing arrow chevrons define either a combo-box or text editable field respectively.

Day / Night Fire Config

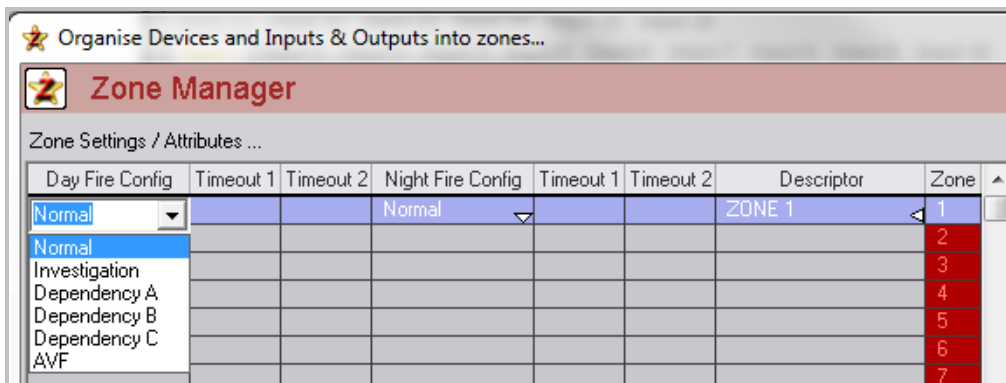

Figure 34: Zone Manager Day/Night configuration

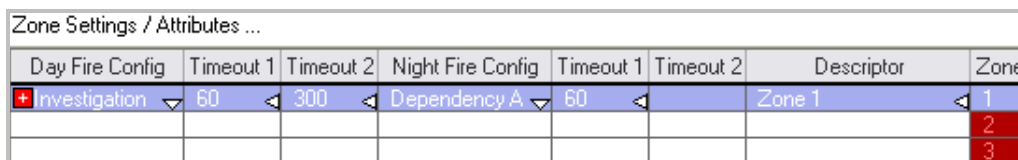



Figure 35: Zone Manager Day/Night configuration

Clicking on the 'Day or Night Fire Config' entry field lowers a combo box, allowing the selection of either Normal, Investigation, Dependency A, B, C or AVF for the currently selected zone; zone number 1.

 **Note:** “Timeout 1 and 2 don’t apply if “Normal” or “Dependency C” is selected.

 **Note:** “Timeout 2” only applies to “Investigation”

Configuring Zone Attributes

Clicking on the ‘Night Fire Config’ entry field lowers a combo box, allowing the selection of either Normal, Investigation, Dependency A, Dependency B or Dependency C for the currently selected zone number; zone number 1.

Clicking on  when “Investigation” or “Dependency C” Day or Night Config is selected allows the zone attributes to be set. The criteria here is that at least one inhibit function must be selected and the MCP override only applies to Investigation.

Investigation

Dependency C

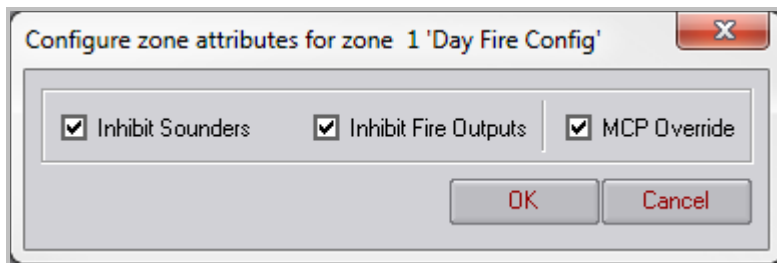

Figure 36: Zone Attribute Window (Investigation)

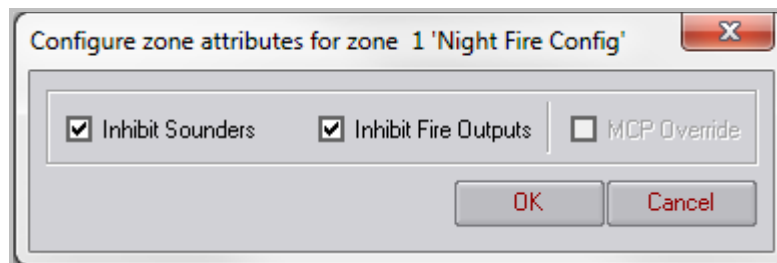

Figure 37: Zone Attribute Window

Day / Night Fire Configure Zone Attributes Error

An error message is displayed if an attempt is made to set the criteria without at least one inhibit function being selected.

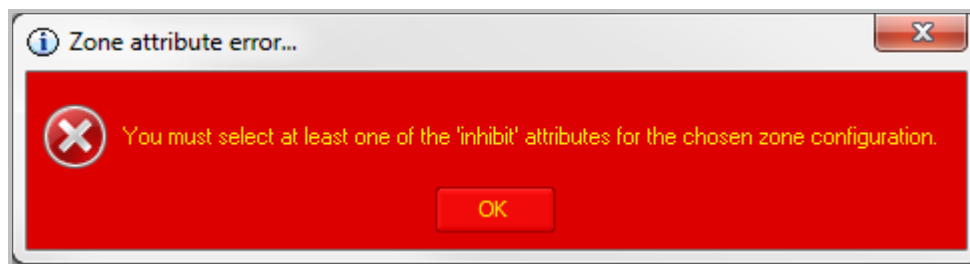

Figure 38: Zone Attribute Error Window

Descriptor

Zone Settings / Attributes ...							
Day Fire Config	Timeout 1	Timeout 2	Night Fire Config	Timeout 1	Timeout 2	Descriptor	Zone
Investigation	0	0	Investigation	0	0	Zone 1	1
							2

Figure 39: Zone Descriptor Window

Clicking on the 'Descriptor' entry field enables an edit box, allowing the user to manually enter a text descriptor for the currently selected zone number; zone number 1.

Entry Selection

Drag-And-Drop I/O To Zone Settings / Attributes ...		
Address	Descriptor	
1:1	CLASS CHANGE INPUT	Panel Input 1
1:2	EVACUATE INPUT	Panel Input 2
1:3	FAULT INPUT	Panel Input 3
1:4	FARE INPUT	Panel Input 4
1:5	SOUNDER OUTPUT 1	Panel Output 1
1:6	SOUNDER OUTPUT 2	Panel Output 2
1:7	SOUNDER OUTPUT 3	Panel Output 3
1:8	SOUNDER OUTPUT 4	Panel Output 4
1:9	AUX POWER OUTPUT 1	Panel Output 5
1:10	AUX POWER OUTPUT 2	Panel Output 6
1:11	FIRE RELAY OUTPUT	Panel Output 7
1:12	ALARM RELAY OUTPUT	Panel Output 8
1:13	FAULT RELAY OUTPUT	Panel Output 9
1:14	FIRE OUTPUT	Panel Output 10
1:15	ANCILLARY OUTPUT	Panel Output 11

Figure 40: I/O Zone Settings

Normal Windows operating system selection criteria apply to the I/O list control in that single or multiple entries can be selected, both in sequence and out of sequence.

The I/O list control holds 2 columns:

- **Column 1: Address:** The address column displays the address of the specified input or output and can take on one of the following 4 forms:
 1. **P:x** – P = Panel number, x = Input or Output number
 2. **P:L.g** – P = Panel number, L = Loop number, g = Group number
 3. **P:L.d** – P = Panel number, L = Loop number, d = Device number
 4. **P:L.D.x** – P = Panel number, L = Loop number, D = Device number, x = Input or Output number
- **Column 2: Descriptor:** The Descriptor column displays the user-created (or system-generated) descriptor, describing what the actual input or output is and/or where it is located, presumably in terms the installer can understand.
- **Column 3: Type:** The Type column simply holds a 'generic' descriptor of the input or output in question; i.e. text describing what the current input or output actually is.

Dragging an Entry

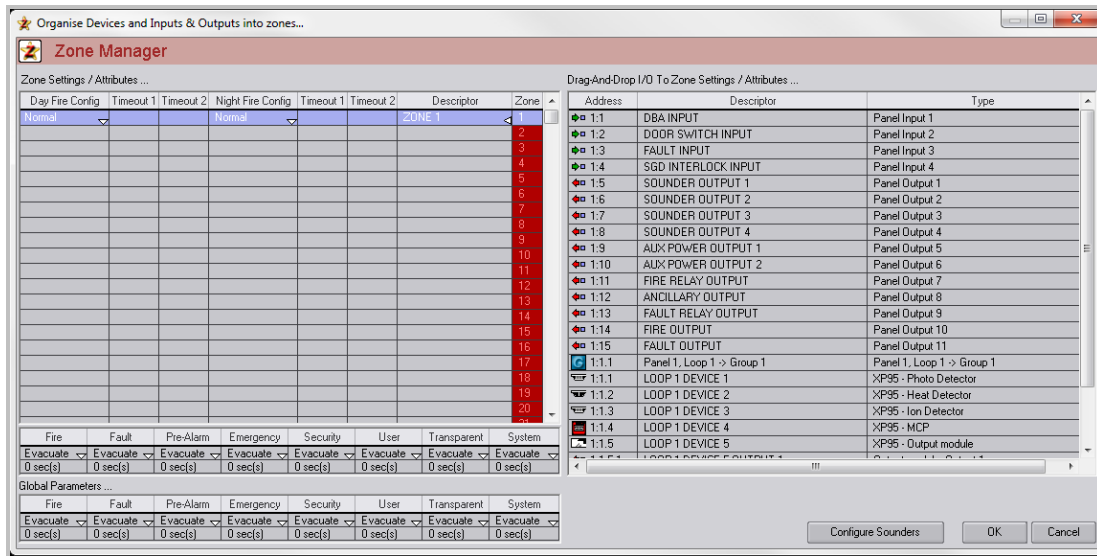

Figure 41: Dragging an Entry

Once one or more I/O entries have been selected the user is able to drag the entries across to the Settings/Attributes window. As can be seen above, the 3 selected entries are being dragged across to the required zone.

Note: That the current drop zone in the Settings/Attributes window is highlighted to notify the user as to the entries' destination zone.

Normal Window operating system drag-and-drop rules and procedures apply.

Dropping an Entry

Once the I/O entries have been dropped (i.e. the user has released the mouse button following a drag operation) over a valid zone in the Settings/Attributes window, the I/O entries are, effectively, moved into that zone and will be displayed as part of the zone's I/O entries.

Following a drop the target zone is automatically highlighted in the Settings/Attributes window and all I/O entries in that zone are displayed in the I/O entry list.

Entry Settings

The Entry Settings (or zone parameters) refer to settings available on a per-zone basis, for the defined types of **Fire**, **Fault**, **Pre-Alarm**, **Emergency**, **Security**, **User**, **Transparent** and **System**.

The proceeding sections describe the various editing options available to zone parameters.

Setting The Action Type

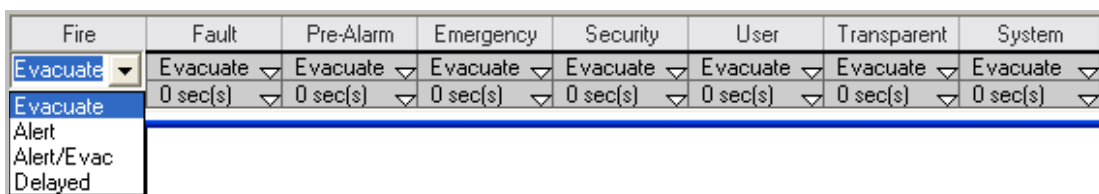

Figure 42: Setting the Action Type Window

The first row of the zone parameters window specifies the action type and this can be changed by clicking on the appropriate field. Note that the downward pointing arrow chevron denotes that this field is editable and initiates a combo-box when clicked.

The resultant combo-box shows the available action types that can be selected; **Evacuate**, **Alert**, **Alert/Evac** and **Delayed**.

Selecting an action type will close the combo-box and update the display.

Setting the Action Type Timeout

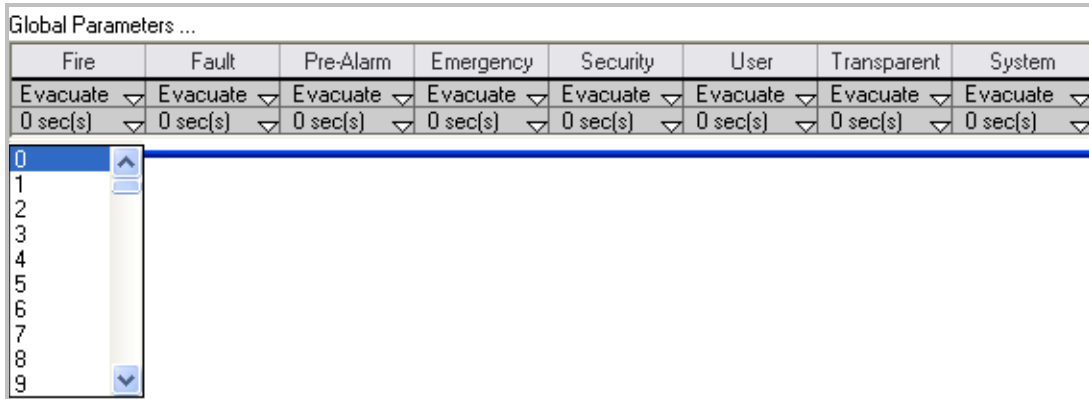



Figure 43: Setting the Action Type Window

The second row of the zone parameters window specifies the action type timeout. This can be changed for Alert / Evac by clicking on the appropriate field.

The resultant combo-box shows the available timeout values that can be selected.

 **Note:** Note that the downward pointing arrow chevron denotes that this field is editable and initiates a combo-box when clicked.

Selecting a timeout value will close the combo-box and update the display.

Global Settings

The Global Settings (or global parameters) refer to settings available on a system-wide (global zone) basis, for the defined types of **Fire**, **Fault**, **Pre-Alarm**, **Emergency**, **Security**, **User**, **Transparent** and **System** and are set in the same way as the “Entry Settings “.

Special Case (Groups)

Groups represent a special case in the Zone Manager and appear purely for informational purposes.

 **Note:** Group entries cannot be re-zoned or dragged to a different zone, by their very nature of being bound to specific loops and zones. A dialog box will be displayed in the event that a user attempts to drag-and-drop a group entry across zones.

The Group Entry

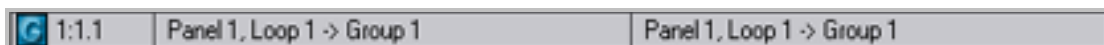

Figure 44: The Group Entry Window

The group entry appears with its own special ‘G’ symbol and placement information.

6.3 Cause & Effect



Clicking on the 'C & E' button opens the Cause & Effect dialog box.

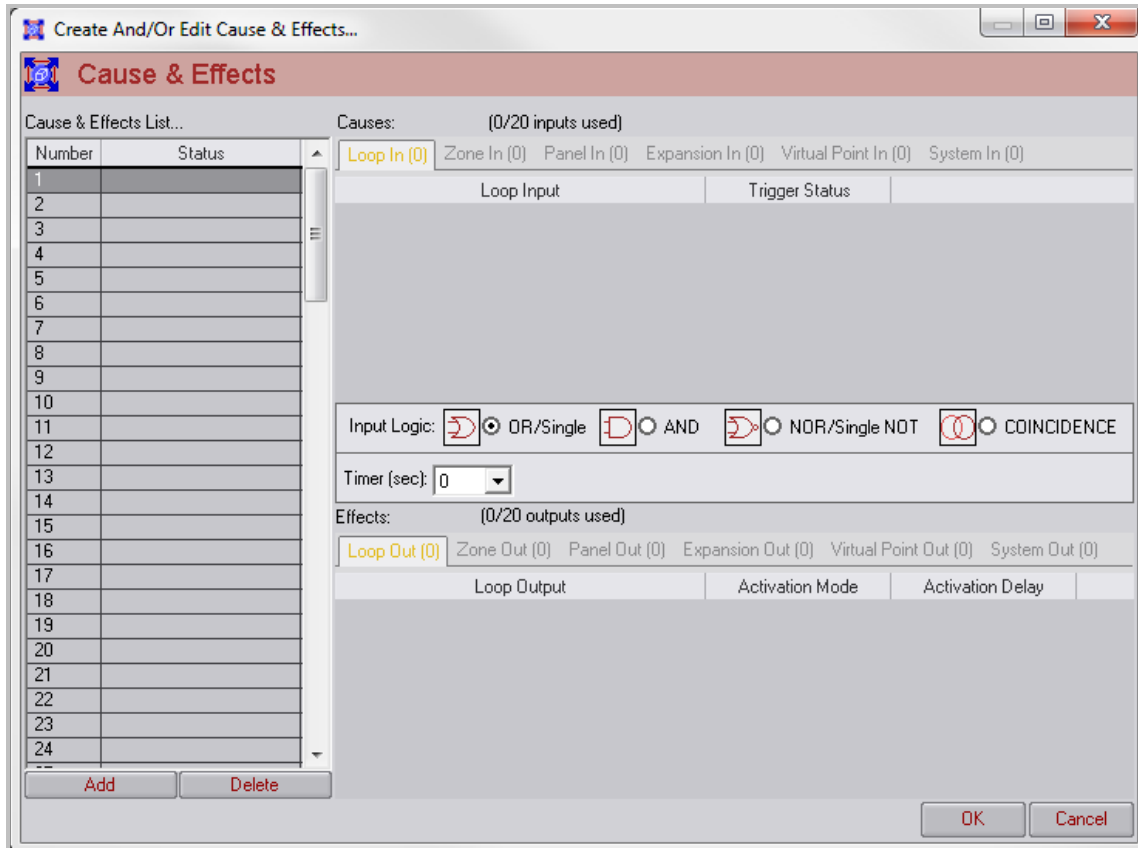

Figure 45: The Main Cause and Effect Window

The Cause & Effect dialog box is used to enter and/or edit Cause & Effect entries.

Cause & effect entries represent a singular function, in which a collection of inputs, when passed through some logic, produce a specific set of outputs.

The Cause & Effect dialog box consists of 4 main areas:

1. The Cause & Effects list: This is a list control holding the defined cause & effects entries in the current configuration. Information on all other areas in this dialog box is reflective of the currently selected cause & effects entry in this list control. Below the list are the Add and Delete buttons, which are used to either add or delete cause & effect entries,
2. The Input tab control: This tab control allows access to the various different types of inputs available to the user for inclusion in a specific cause & effect entry; see below,
3. The Output tab control: This tab control allows access to the various different types of outputs available to the user for inclusion in a specific cause & effect entry; see below,
4. The Logic window: This window consists of 4 possible logic operations to be used on the selected inputs, for the purpose of deciding whether certain outputs will be activated or not. It also provides access to the Cause and Effect time value.

Adding/Deleting A Cause & Effect

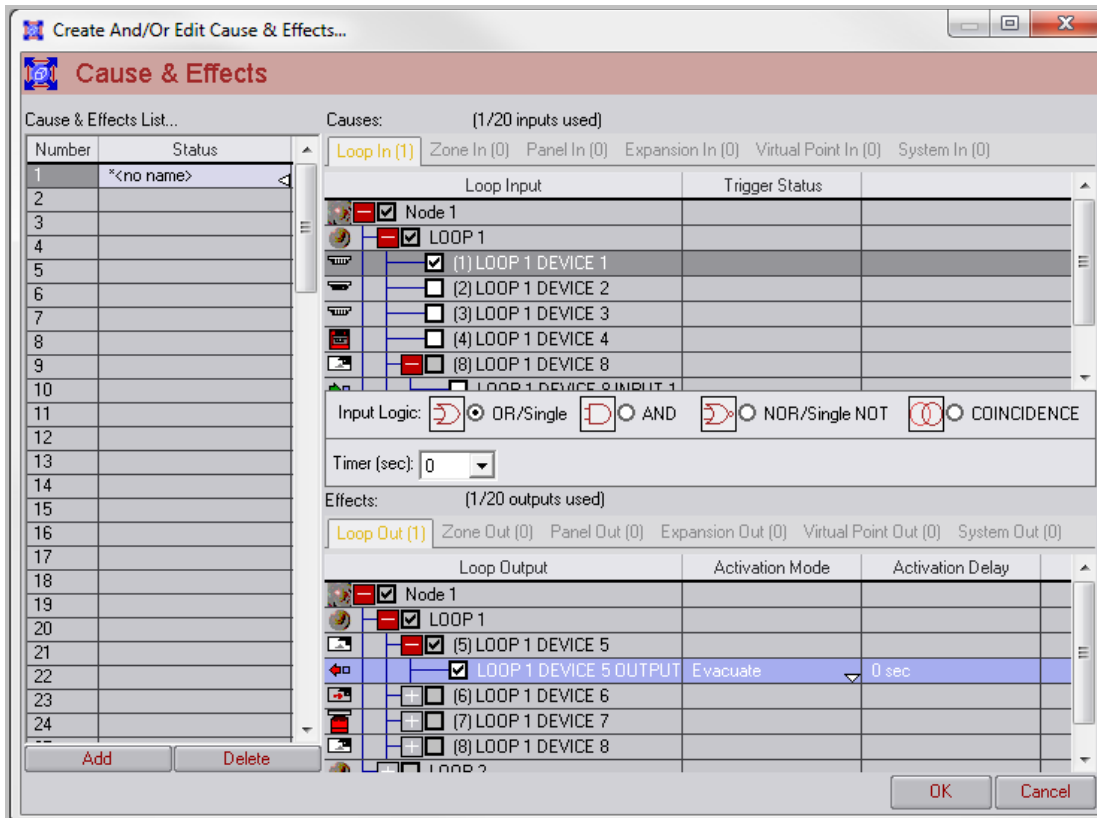

Figure 46: Cause and Effect Window

To add a cause & effect entry the user simply needs to click on the ‘Add’ button. The new cause & effect entry will be created at a location in the list at either the entry that is currently highlighted, if that entry is currently empty, or at the next available entry following the currently highlighted one.

Once an entry has been added it is now available for editing, with the Cause & Effect dialog box enabling the Input and Output tab controls, as well as providing the default cause & effect entry name of “<no name>”.



Note: The left-pointing arrow chevron next to the cause & effects entry descriptor (in the Status column), denoting that this descriptor is editable.

Deleting a cause & effect entry is a simple matter of selecting the desired cause & effect entry to delete, by highlighting the appropriate entry in the Cause & Effect List, and then clicking on the Delete button. The cause & effect entry’s descriptor will then become blank for the entry and the Input and Output controls will be disabled.

Descriptor

The descriptor of an existing cause & effects entry can be edited by single clicking over its existing descriptor, as can be seen above.

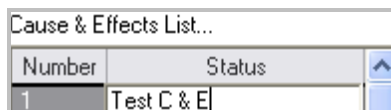

Figure 47: Cause and Effect Descriptor Window

Logic Selection



Figure 48: Logic Selection Window

The logic selection window allows the user to select the logic function to be performed on the selected inputs, for the purpose of producing output logic to be used in deciding whether to turn on or off the selected outputs.

The available logic functions are:

- AND: Two or more input statuses are AND-ed together,
- OR/Single: This logic function should be selected when only one input has been selected for the current cause & effect entry. If more than one input has been selected then this causes the input statuses to be OR-ed together,
- NOR/Single NOT: When only one input has been selected then this logic function will invert that input's status. If more than one input has been selected then this causes the input statuses to be first OR-ed and then inverted,
- COINCIDENCE: Two or more input statuses will cause an active output status if at least two of the input statuses are active.

Extra Option

Immediately below the logic selection window (and referred to as being part of the logic window) is the 'extra option' window, which allows the user to specify a cause & effect timer value.

Cause & Effect Inputs

The available input types for cause & effect input programming are Loop Inputs, Zone Inputs, Panel Inputs, Expansion Inputs, Virtual Point Inputs and System Inputs.

Where possible the inputs are displayed to the user in a tree-like manner, graphically showing their hierarchal place for that particular input type. As per any Windows operating system tree control, the trees may be expanded and collapsed to either show or hide branches.

Some inputs may be greyed and, so, cannot be edited.

All branches and inputs 'own' a checkbox which, if checked, denotes the following:

- On a branch: A checked checkbox on a branch tells us that at least one of its 'child' inputs has been selected; this exists to facilitate easier searching for selected inputs, as users can use these markers to traverse down a particular set of branches to find the selected input,
- On an input: A checked checkbox on an input tells us that this particular input has been selected. Once an input has been selected, all parent branches are also automatically checked (see point above).

Loop

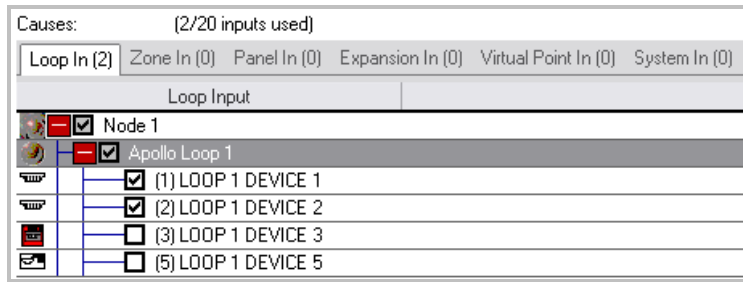



Figure 49: Loop Device Window

The above shows an example of a loop input being selected. In this case the selected input’s ‘location’ is on Node 1, Loop 1, Device 1, Input 2.

 **Note:** That only defined devices (devices which have been added to a loop) will be available for selection.

Zone

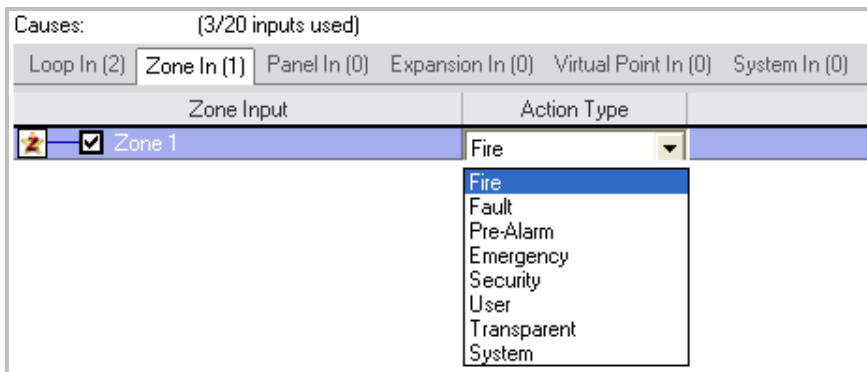



Figure 50: Selecting Action Type

When selecting a zone, the user also has the option to associate an Action Type with that zone. Clicking on the current Action Type for that zone opens a combo box, allowing the user to select a different Action Type.

 **Note:** That only those zones already defined will be available for selection.

Panel

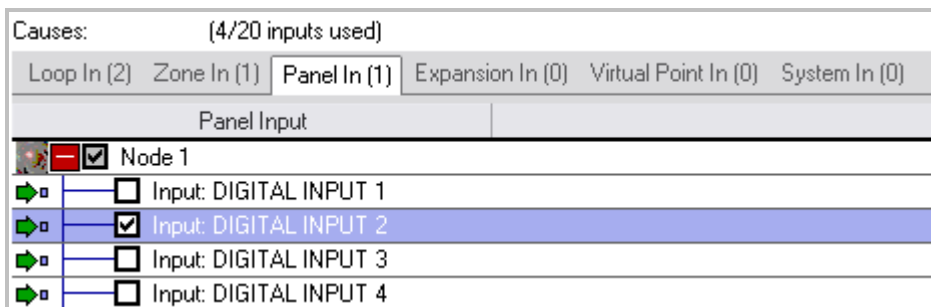

Figure 51: Panel Input

The above shows a panel input being selected. In this case, the panel input is Input 2.

Expansion

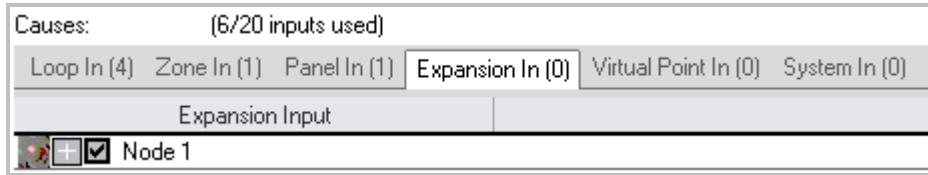

Figure 52: Expansion Module Setup

The above shows the list of available expansion module inputs for selection, e.g. Switch and Indicator Card.

Virtual Point

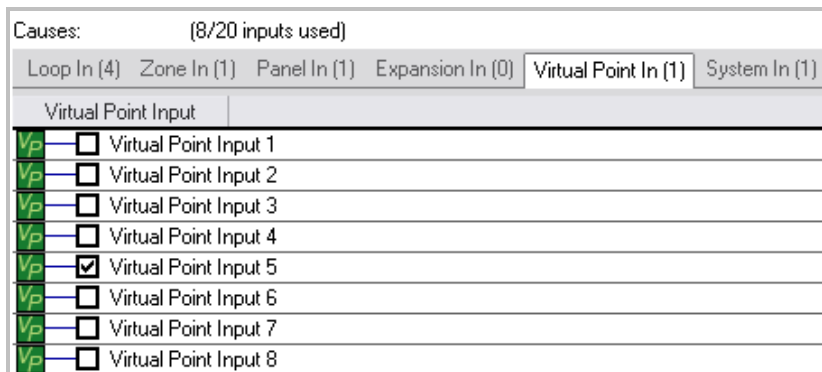

Figure 53: Showing 1 virtual point selected

There are a maximum of 100 virtual points per configuration used as temporary ‘storage’, primarily as a means of receiving the result of a logic operation from another cause & effect entry.

System

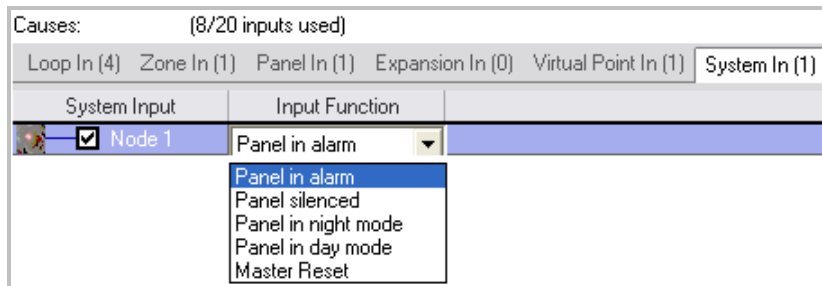

Figure 54: System input selection.

System inputs are node (panel) based and there can be only one per panel, per cause & effect entry.

Once a node has been selected the user can open the Input Function combo box, by clicking on the current Input Function, and select the required system input function.

Cause & Effect Outputs

The available output types for cause & effect output programming are Loop Outputs, Zone Outputs, Panel Outputs, Expansion Outputs, Virtual Point Outputs and System Outputs; these are explained more fully in the following sections.

Where possible the outputs are displayed to the user in a tree-like manner, graphically showing their hierarchal place for that particular output type. As per any Windows operating system tree control, the trees may be expanded and collapsed to either show or hide branches.

Some outputs may be greyed and, so, cannot be edited. A greyed output may occur, for example, if that output has already been used in another cause & effect entry; i.e. any output can only be selected once for any configuration.

All branches and outputs 'own' a checkbox which, if checked, denotes the following:

On a branch: A checked checkbox on a branch tells us that at least one of its 'child' outputs has been selected; this exists to facilitate easier searching for selected outputs, as users can use these markers to traverse down a particular set of branches to find the selected output,

On an output: A checked checkbox on an output tells us that this particular output has been selected. Once an output has been selected, all parent branches are also automatically checked (see point above).

Loop

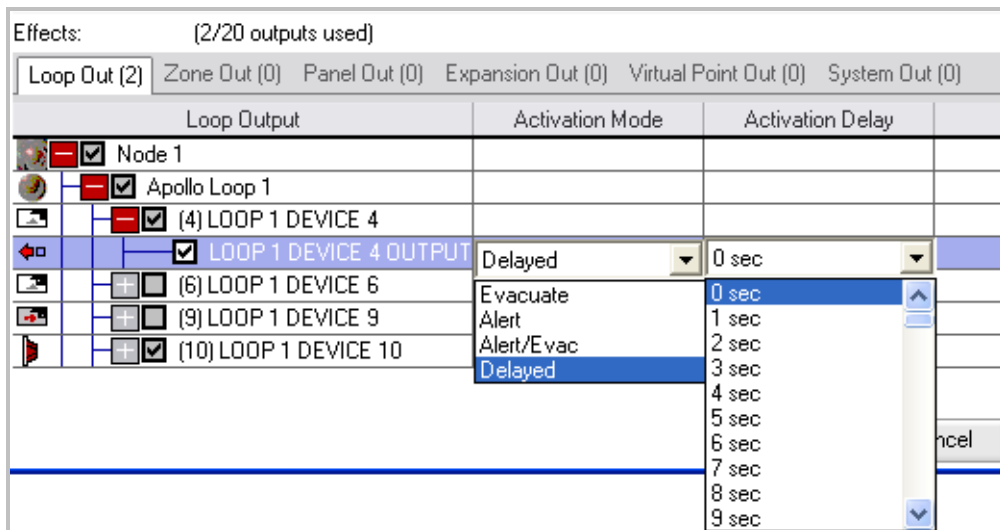



Figure 55: Loop Output Selection

The above shows an example of a loop output being selected. In this case the selected output's 'location' is on Node 1, Loop 1, Device 4, Output 4.

Once a selection has been made the user can change the Activation Mode and Activation Delay (if applicable) for that output, by clicking on the current Activation Mode and Activation Delay fields for that output. This will open a combo box for the respective field and allow the user to make a new selection.

 **Note:** That only defined devices (devices which have been added to a loop) will be available for selection.

Zone

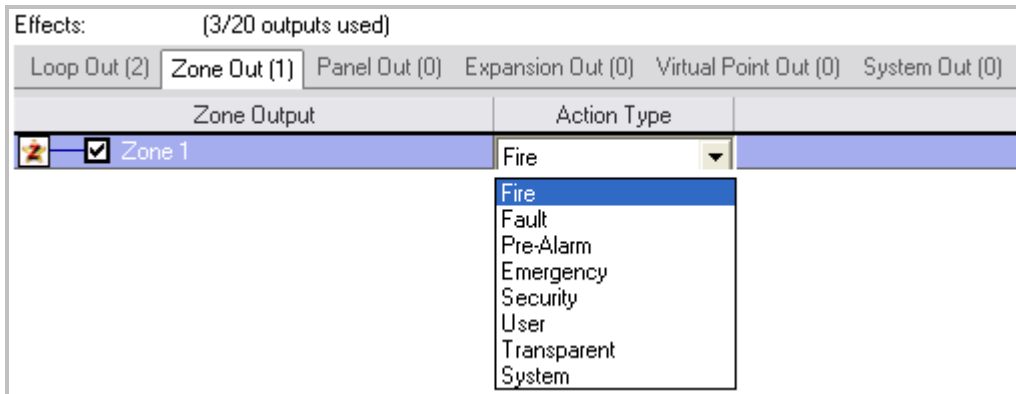



Figure 56: Zone Output Action Type

The above shows a zone output being selected (Zone 1).

When selecting a zone, the user also has the option to associate an Action Type with that zone. Clicking on the current Action Type for that zone opens a combo box, allowing the user to select a different Action Type.

 **Note:** That only those zones already defined will be available for selection.

Panel

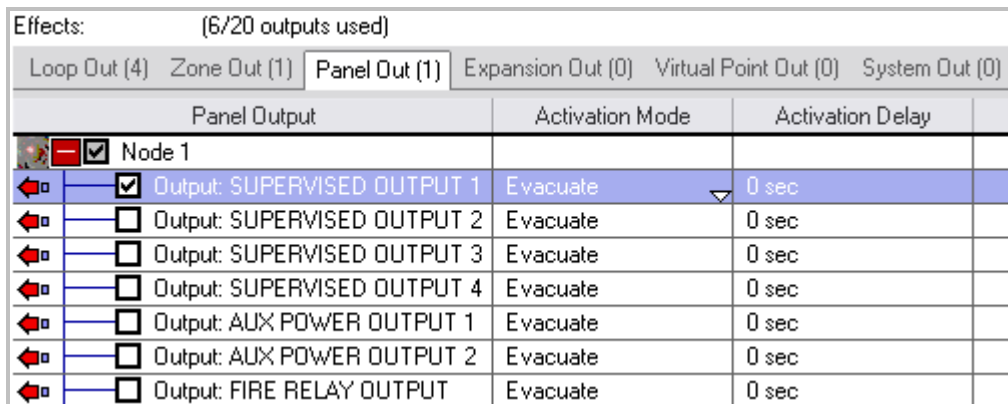

Figure 57: Panel Out Activation Mode

The above shows a panel output being selected. In this case Supervised Output 1.

Once a selection has been made the user can change the Activation Mode and Activation Delay for that output, by clicking on the current Activation Mode and Activation Delay fields for that output. This will open a combo box for the respective field and allow the user to make a new selection.

Expansion

Effects: (6/20 outputs used)						
Loop Out (4)		Zone Out (1)	Panel Out (1)	Expansion Out (0)	Virtual Point Out (0)	System Out (0)
Expansion Output		Activation Mode		Activation Delay		
Node 1						
8-Way Relay (Addr: 01, Ref: 02)						
<input type="checkbox"/>	Output 1	Evacuate		0 sec		
<input type="checkbox"/>	Output 2	Evacuate		0 sec		
<input type="checkbox"/>	Output 3	Evacuate		0 sec		
<input type="checkbox"/>	Output 4	Evacuate		0 sec		
<input type="checkbox"/>	Output 5	Evacuate		0 sec		
<input type="checkbox"/>	Output 6	Evacuate		0 sec		

Figure 58: Expansion Out Activation Mode

The above shows the list of available expansion module outputs for selection, with Output 1 on Node 1 currently selected.

Once a selection has been made the user can change the Activation Mode and Activation Delay for that output, by clicking on the current Activation Mode and Activation Delay fields for that output. This will open a combo box for the respective field and allow the user to make a new selection.

Virtual Point

Effects: (8/20 outputs used)						
Loop Out (4)		Zone Out (1)	Panel Out (1)	Expansion Out (0)	Virtual Point Out (2)	System Out (0)
Virtual Point Output						
<input type="checkbox"/>	Virtual Point Output 1					
<input checked="" type="checkbox"/>	Virtual Point Output 2					
<input checked="" type="checkbox"/>	Virtual Point Output 3					
<input type="checkbox"/>	Virtual Point Output 4					
<input type="checkbox"/>	Virtual Point Output 5					
<input type="checkbox"/>	Virtual Point Output 6					
<input type="checkbox"/>	Virtual Point Output 7					
<input type="checkbox"/>	Virtual Point Output 8					

Figure 59: Virtual Output Select

The above shows two virtual points being selected.

There are a maximum of 100 virtual points per configuration and they are used as temporary ‘storage’, primarily as a means of passing the result of a logic operation to another cause & effect entry.

System

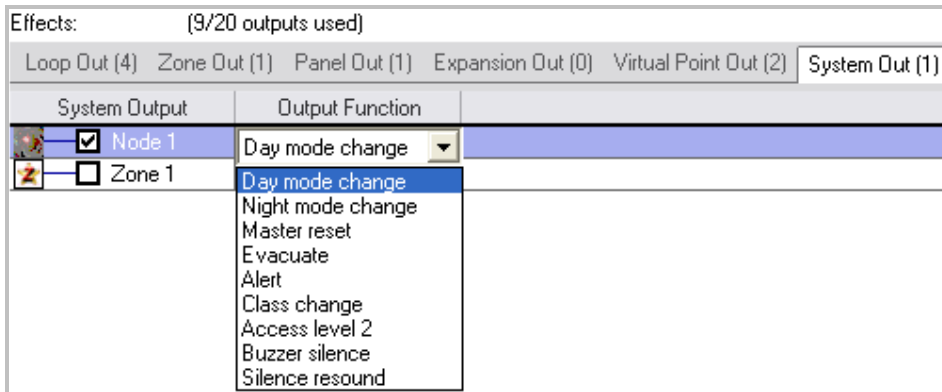



Figure 60: System Output Function

The above shows a system output being selected.

System outputs can be node (panel) based or zone based and there can be only one per panel, per cause & effect entry.

Once a node or zone has been selected the user can open the Output Function combo box, by clicking on the current Output Function, and select the required system output function.

 **Note:** That only defined zones and nodes will be available for selection here.

Status Complete

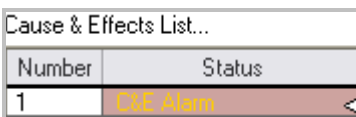

As shown a valid cause & effect entry will appear in the Cause & Effect List. The Status text displays the user-edited descriptor and is highlighted in yellow, to represent its validity.

Status Incomplete



An incomplete (or erroneous) cause & effect entry is highlighted with its descriptor preceded by a '*' character.

 **Note:** That you cannot close the Cause & Effect dialog box by clicking on the 'OK' button, while there are incomplete cause & effects entries present.

Error

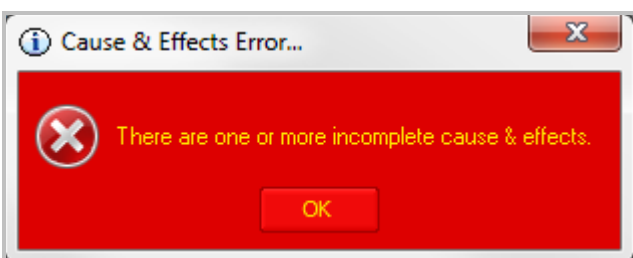

Attempting to close the Cause & Effects dialog box, by clicking the 'OK' button, will result in this dialog box being shown

6.4 Security Settings



Clicking on the 'Security' button opens the Security dialog box

The Security dialog box allows the user to enter and/or edit passwords and access levels, which will be used to gain access to the panels, as defined by the current configuration.

The dialog box consists solely of a list control with 3 columns:

1. ID: This is a unique identification number, which represents the position of its associated access level and password,
2. Access Level: This column holds the specified access level (1, 2 or 3) for its associated ID,
3. Password: This is the 4 digit password which will be used to gain access to a panel at the associated Access Level.

A blank Access Level denotes an empty and, thus, inoperable ID.



Note: The downward pointing arrow chevron denoting the editable fields.

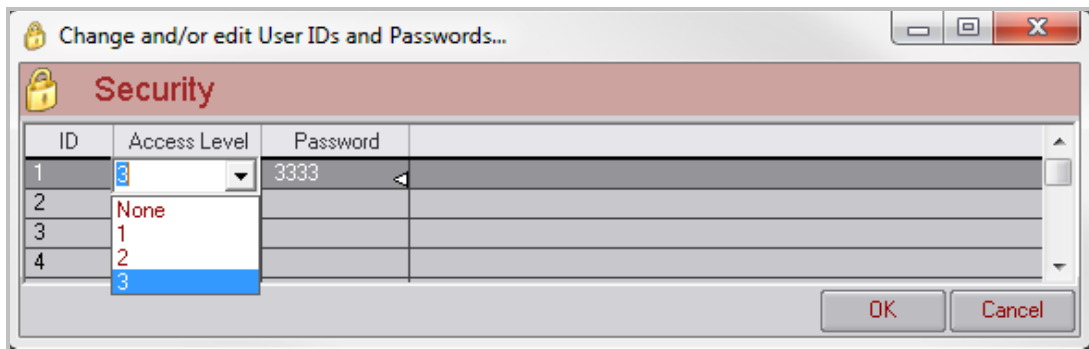

Figure 61: Editing Passwords

Adding/Editing a Security Entry

Adding a security entry is a simple matter of finding a blank entry and clicking on the Access Level field, to open the combo box and allow the user to select their required access level. Upon selecting a valid access level (something other than 'None') the Password field becomes editable, as denoted by the left pointing arrow chevron, allowing the user to specify a new password.

To remove a security entry the user simply needs to click on the Access Level field of the entry to remove and then select 'None' from the combo box.

Access Level

The combo box is opened when the user clicks on the Access Level field of a specific security entry ID.

Selecting either 1, 2 or 3 will make the Password field editable, while selecting 'None' will disable this security entry.

Password

The Password field of the security entry is entered / edited by clicking within the box and typing in the password.

6.5 Notes

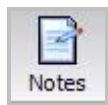

Clicking on the 'Notes' button opens the Notes dialog box

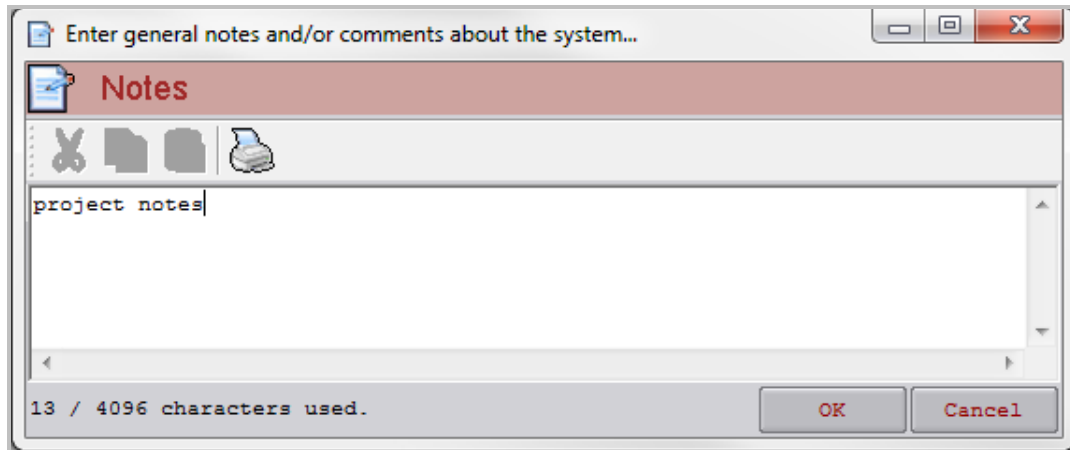

Figure 62: General notes about project

The Notes dialog box provides a means of adding application-specific textual information to a configuration. The actual contents of the Notes is not used by the panel but merely stored within its flash memory; its main purpose is as a tool to allow installers and technicians a means of documenting the installation or tracking changes.

The Notes dialog box consists of a large text input area, 3 clipboard operation buttons and a print button.

The user may enter, at most, 4096 characters and can keep track of their current character count via the counter at the bottom left of the dialog box.

For more information on the operation of the clipboard functions see sections on Cut, Copy and (Paste operation.

Printing

Clicking on the Print button opens the Windows operating system generic printer dialog box, allowing the user to select and setup the printer to receive the text from the Notes dialog box.

6.6 The Details Pane Toolbar

The Details Pane Toolbar resides at the top of the Details Pane and displays context-dependent toolbar buttons; i.e. the appearance and make-up of the toolbar changes, depending on what is currently displayed / active in the Details Pane.

Typically, clicking one of the Details Pane Toolbar buttons will invoke a submenu, appearing just below the button, requiring more user input.



Not available when "Modules" selected. - Clicking on the Loop button opens a sub-menu with one or more of the following options:

- Enable Loop: If there are more loops available, than are currently enabled, this item will appear, allowing the user to enable a specific loop,
- Disable Loop: This item appears when a loop is currently selected and is allowed to be disabled; i.e. a one loop panel will not allow the disabling of its only loop,



Only available when a device is highlighted - Clicking on the Devices button opens a sub-menu which allows the user to either add a device or remove a device.

The removal option will only appear if a device is currently selected.

Adding a device can only be performed if either a device, or an empty device address, is currently selected.



Only available when a module / Add-On is highlighted - Clicking on the Add-Ons button opens a sub-menu with options for adding an Add-On or removing an Add-On. The removal option will only appear if an Add-On is currently selected.

Adding an Add-On can only be performed if the total number of Add-Ons (of that specific type or in total) has not been reached.



Clicking on the Properties button will open the editing dialog box associated with the currently selected entity type; i.e. if a device is currently highlighted then the device editing dialog box will open, etc.

7 Configuring Panels

The Tree View

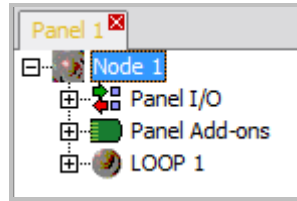

Figure 63: Panel Tree View

The above shows how a panel is represented within the Tree View.

In panel terms the Tree View consists of a tab control, as the parent, with a tree view control beneath it. Each tab of the tab control represents the panel in the system.

7.1 The Details View

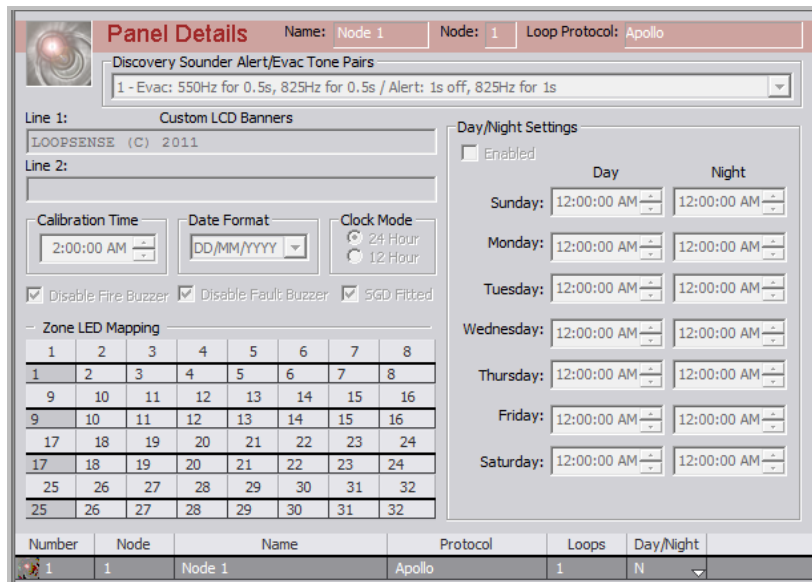

Figure 64: Panel Details Screen

The above is displayed as part of the Details Pane of available configuration panel-specific data. It is displayed at the top of the Details Pane and is a non-editable (as with other non-editable screens the information is shaded), accurate representation of editable fields for a panel.

7.2 The List View

Number	Node	Name	Protocol	Loops	Day/Night
1	1	Node 1	Apollo	1	N
					Y
					N

Figure 65: Panel list View

The panel List View appears immediately below the panel Details View and consists of a summary of the current configuration.

Double-clicking on any entry in this list will open the editing dialog box for that panel.

7.3 Editing

The panel editing dialog box consists of two types of fields:

1. Non-editable (informational) fields:
 - Name: The name of this panel, in nodal terms,
 - Node: The node number of this panel,
 - Loop Protocol: The loop protocol used by this panel when processing loop devices.
2. Editable fields:
 - Custom LCD Banners: These are 40 character long strings that are displayed on the main LCD screen on the panel; i.e. there are two lines allocated on the main LCD screen for these two banner strings,
 - Calibration Time: This is the time of day that any calibration should take place,
 - Date Format: The date format, for display purposes, is changed here,
 - Clock Mode: The user can alternate between 24 and 12 hour clock modes,
 - Zone LED Mapping: This set of fields allows the user to provide mapping between zone numbers and LED's on a zone LED display board.

Zone LED Mapping								
	1	2	3	4	5	6	7	8
1	2	3	4	5	6	7	8	
2	10	11	12	13	14	15	16	
3	10	11	12	13	14	15	16	
4	18	19	20	21	22	23	24	
5	18	19	20	21	22	23	24	
6	26	27	28	29	30	31	32	
7	26	27	28	29	30	31	32	
8								
9								
10								

Figure 66: Zone LED Mapping

- Day / Night Settings: This set of fields allows the user to set the times, on various days of the week, at which day and night start. These fields only become editable (and applicable) when the 'Enabled' checkbox is checked.

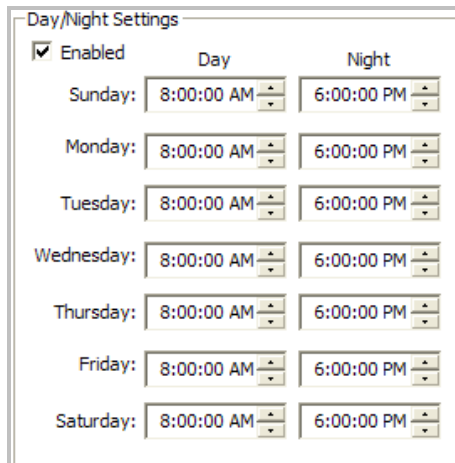

Day/Night Settings

Enabled

	Day	Night
Sunday:	8:00:00 AM	6:00:00 PM
Monday:	8:00:00 AM	6:00:00 PM
Tuesday:	8:00:00 AM	6:00:00 PM
Wednesday:	8:00:00 AM	6:00:00 PM
Thursday:	8:00:00 AM	6:00:00 PM
Friday:	8:00:00 AM	6:00:00 PM
Saturday:	8:00:00 AM	6:00:00 PM

Figure 67: Day / Night Settings

- Misc_ The tick boxes allow Fire and Fault Buzzer to be disabled (Default) or enabled and whether a Signal Generating Device (SGD) is fitted to the panel (Default = Fitted)

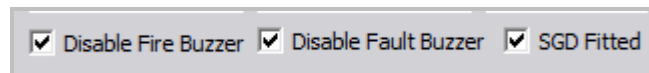

Disable Fire Buzzer Disable Fault Buzzer SGD Fitted

Figure 68: Misc Panel Settings

7.4 The Panel Menu

The Panel Menu appears when the user right-clicks over a panel entry in the Tree View.

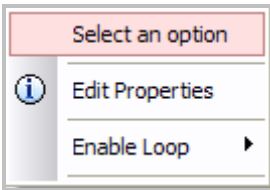

The default menu, with the 'Enable Loop' item available; i.e. the panel in question can have multiple loops and not all loops have been enabled. On single loop panels this item is unavailable.

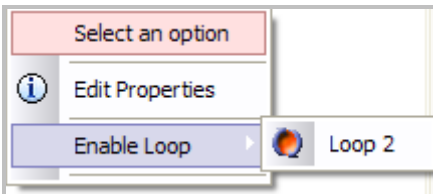

The menu, as described, above, but with the 'Enable Loop' item selected.

7.5 Panel I/O - Inputs

Panel I/O refers to the Inputs and Outputs physically present on the panel hardware. These Inputs and Outputs can be programmed, to varying degrees, to produce desired outcomes.

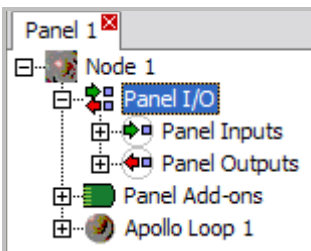

The Tree View with the Panel I/O tree item expanded to show the Panel Inputs and Panel Outputs tree items which are, themselves, expandable.

As presented, these inputs refer to the programmable inputs physically located on the panel.

The Tree View

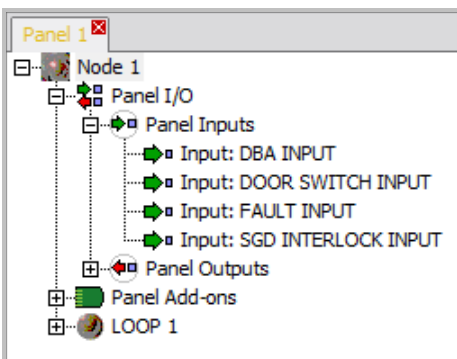

The expanded view of the Panel Inputs. In this case, this panel has 4 programmable inputs available for editing.

Selecting one of these inputs will update the Details Pane with the respective input's information, while double-clicking on the input will open its editing dialog box.

The Details View

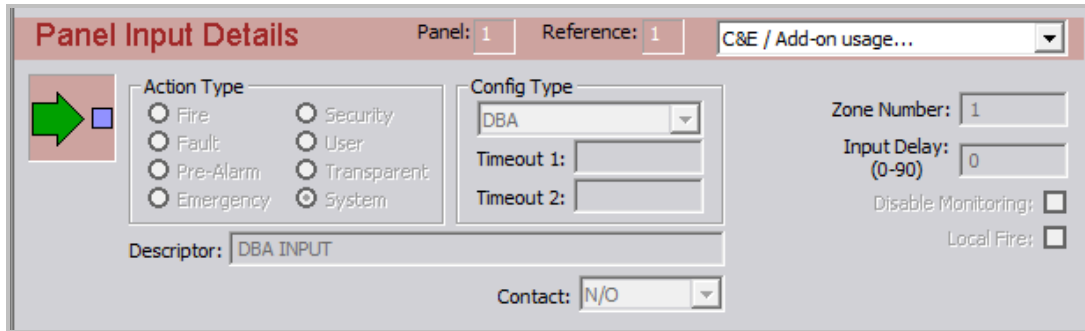

Figure 69: Panel Input Details Window

The above is displayed as part of the Details Pane representation of the information available to the configuration of panel-input-specific data. It is displayed at the top portion of the Details Pane and is a non-editable, accurate representation of editable fields for a panel input. See the section on editing for an explanation of the fields.

The List View

Ref	Descriptor	Type	Zone	Action	Config	Monitoring	Contact	Input Delay
1	Input: CLASS CHANGE INPUT	INPUT	1	Transparent	Class Change	Y	N/O	0
2	Input: EVACUATE INPUT	INPUT	1	System	Evacuate	Y	N/O	0
3	Input: FAULT INPUT	INPUT	1	Fault	Non Latching	Y	N/O	0
4	Input: FARE INPUT	INPUT	1	System	FARE	Y	N/O	0

Figure 70: Input List View

The panel input List View appears immediately below the panel input Details View and consists of a summary of all available panel inputs physically assigned to the current panel.

Double-clicking on any entry in this list will open the editing dialog box for that panel input; see below.

Editing

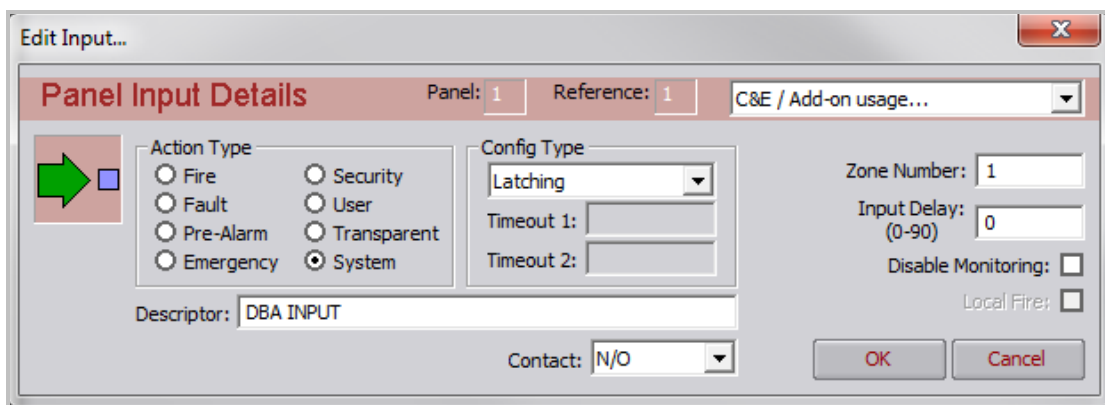

Figure 71: Editing Input Type

The panel input editing dialog box consists of two types of fields:

1. Non-editable (informational) fields:
 - Panel: The panel number this panel input belongs to,
 - Reference: The reference number of this panel input, with respect to the panel it belongs to,

2. Editable fields:

- Action Type: The user can select one Action Type to associate with this panel input,

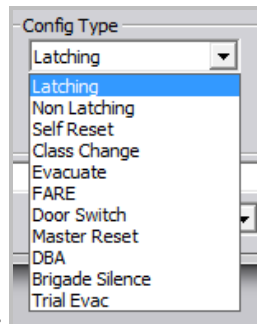

- Config Type: The user has the ability to select whether this panel input will exhibit behaviour consistent with a Latching, Non Latching, Self Reset, Class Change, Evacuate, FARE, Door Switch, Master Reset, DBA Brigade Silence or Trial Evac input.

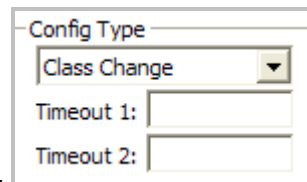

- Configuration Timeout 1 & 2– The user can specify a timeout to be associated with the Config Type, if it requires it,
- Contact: the available options for setting whether this panel input is N/O (Normally Open) or N/C (Normally Closed),
- Zone Number: Allows entering of a zone number between 1 and 999,
- Input Delay: The input delay, between 0 and 90 seconds,
- Disable Monitoring: Check this checkbox to disable monitoring of this panel input,
- Local Fire: Selected if Input is not to call the brigade
- Descriptor: Allows the user to enter a 40 character descriptor describing this panel input
- Cause & Effects and Add-On Usage –show the Cause & Effects Usage combo box, which lists all cause & effects and Add-On entries that use this panel input.

Menu

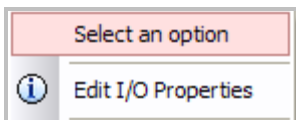

Right-clicking on a panel input from the Tree View opens the option menu. It contains an option to open the panel input editing dialog box; see section above.

7.6 Panel I/O - Outputs

These outputs refer to the programmable outputs physically located on the panel hardware.

The Tree View

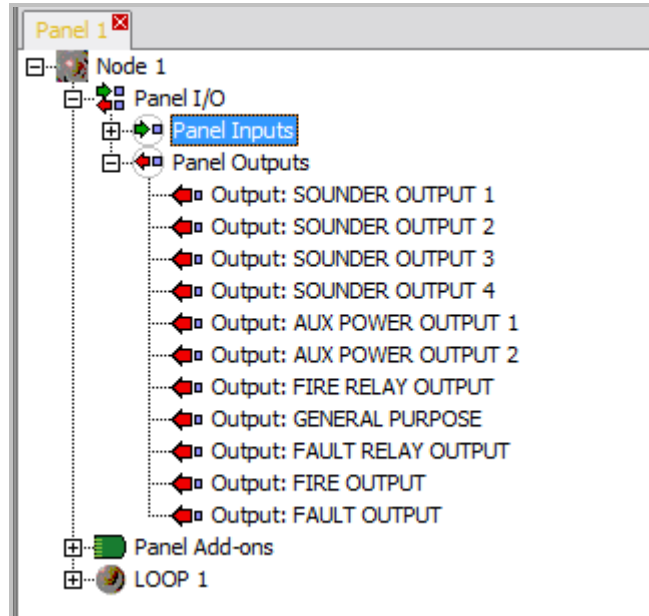

Figure 72: Panel I/O Outputs Window

The above shows the expanded view of the Panel Outputs. In this case, this panel has 11 programmable outputs available for editing.

Selecting one of these outputs will update the Details Pane with the respective output's information, while double-clicking on the output will open its editing dialog box.

The Details View

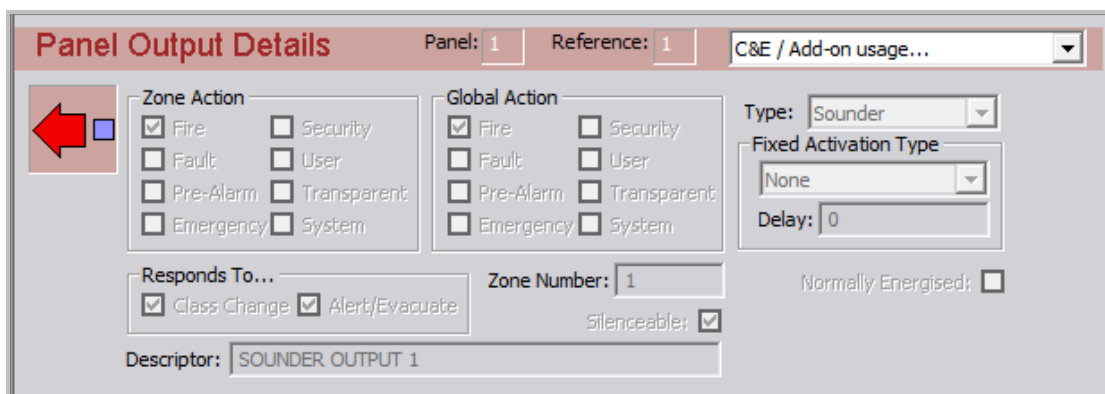

Figure 73: Panel I/O Output Details

The above is displayed as part of the Details Pane representation of the information available to the configuration of panel-output-specific data. It is displayed at the top portion of the Details Pane and is a non-editable, accurate representation of editable fields for a panel output.

The List View

Ref	Descriptor	Type	Zone	Output	Activation	Silenceable
1	Output: SOUNDER OUTPUT 1	SUPOUT	1	Sounder	None	Y
2	Output: SOUNDER OUTPUT 2	SUPOUT	1	Sounder	None	Y
3	Output: SOUNDER OUTPUT 3	SUPOUT	1	Sounder	None	Y
4	Output: SOUNDER OUTPUT 4	SUPOUT	1	Sounder	None	Y
5	Output: AUX POWER OUTPUT 1	AUXOUT	1	Unsupervised	Continuous	N
6	Output: AUX POWER OUTPUT 2	AUXOUT	1	Unsupervised	Continuous	N
7	Output: FIRE RELAY OUTPUT	RELAY	1	Fire	None	N
8	Output: GENERAL PURPOSE	RELAY	1	Unsupervised	None	N
9	Output: FAULT RELAY OUTPUT	RELAY	1	Fault	None	N
10	Output: FIRE OUTPUT	OC OUT	1	Fire	None	N
11	Output: FAULT OUTPUT	OC OUT	1	Fault	None	N

Figure 74: Panel Output List View

The panel output List View appears immediately below the panel output Details View and consists of a summary of all available panel outputs physically assigned to the current panel.

Double-clicking on any entry in this list will open the editing dialog box for that panel output.

Editing

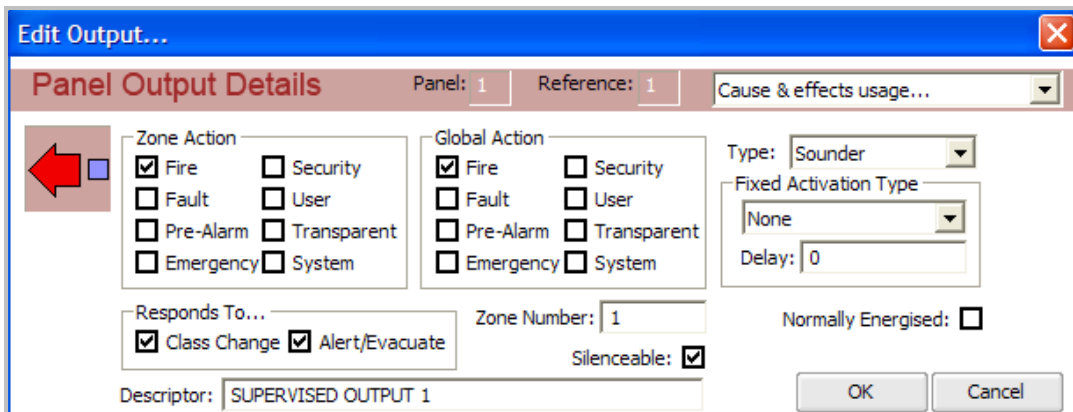

Figure 75: Panel Output Edit Screen

The panel input editing dialog box consists of two types of fields:

Non-editable (informational) fields:

1. Panel: The panel number this panel output belongs to,
 - Reference: The reference number of this panel output, with respect to the panel it belongs to,
2. Editable fields:
 - Global Action: The user can select one or more Global Action Type to associate with this panel output,
 - Zone Action: The user can select one or more Zone Action Type to associate with this panel output,
 - Responds To:
 - Class Change: Specifies that this panel output will respond to a Class Change request,

- Evacuate: Specifies that this panel output will respond to an Evacuate request.
- Silenceable: This checkbox is checked to force this panel output to become silenceable,
- Zone Number: Allows entering of a zone number between 1 and 999,

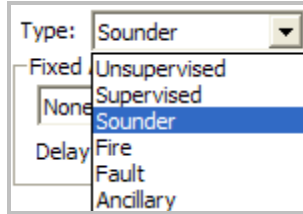

- Type: This combo box, allows the user to set the output type of this panel output; it can be either Un-Monitored, Monitored, Sounder, Fire, Fault or Ancillary,

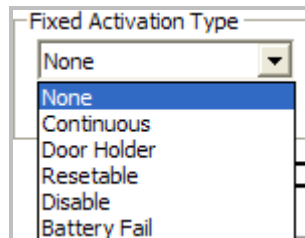

- Fixed Activation Type: shows the available Fixed Activation Types that can be assigned to this panel output; Normal, Door Holder or Resettable, Disable and Battery Fail.
- Fixed Activation Type Delay: Allows the user to enter a time delay to associate with the chosen Fixed Activation Type, if required,
- Delay - Sets an operational delay
- Normally Energised: This checkbox is checked to force this panel output to behave as Normally Energised,
- Descriptor: Allows the user to enter a 40 character descriptor describing this panel output,
- Cause & Effects and Add-On Usage: list all cause & effects and Add-On entries that use this panel output.

Menu

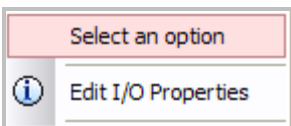

Right-clicking on a panel output from the Tree View opens the menu. It contains an option to open the panel output editing dialog box.

8 Configuring Loops & Devices

The Loop Overview

The Loop is the fundamental ingredient for the panel, allowing the panel to scan devices and detectors on the loop and perform actions based on what it detects.

The loop is represented in the Tree View similarly to other entities in the panel, in that it is displayed as a parent to a list of addresses, with each address coinciding to a physical address on the loop.

By default, each new panel configuration begins with all empty addresses.

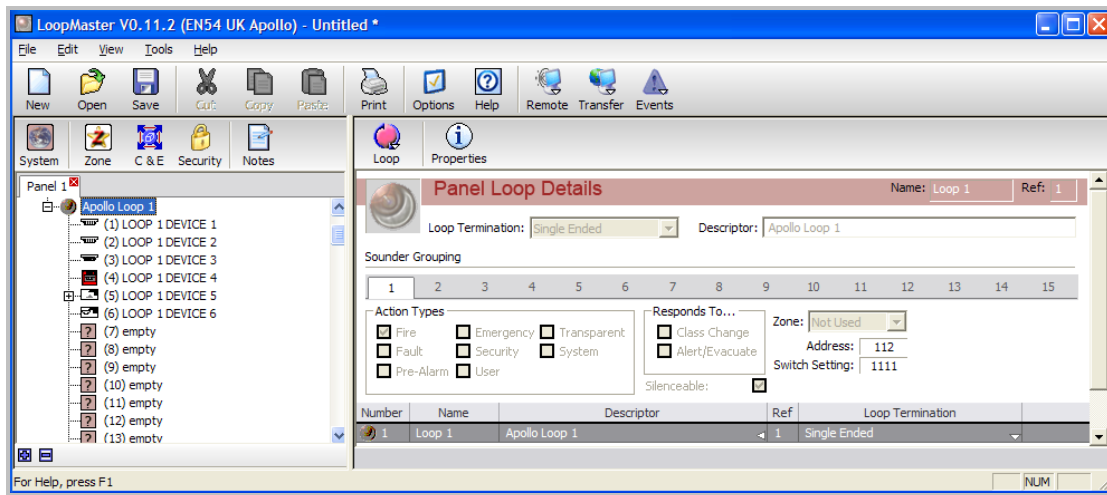

Figure 76: Loop & Device Edit screen

The Tree View

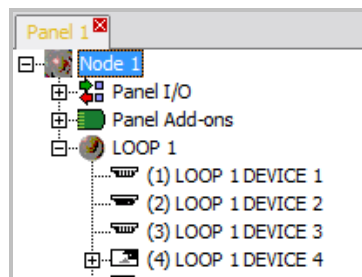

Figure 77: The Tree View

As can be seen in the above the Loop is represented as a parent, with each physical address a separate child, available for editing.

Selecting the parent Loop will update the Details Pane with the respective Loop's information, while double-clicking on the Loop will open its editing dialog box.

Note that the number of loops available to a panel is based on the panel model the current configuration is being written for and/or regional requirements or restrictions.

The Details View

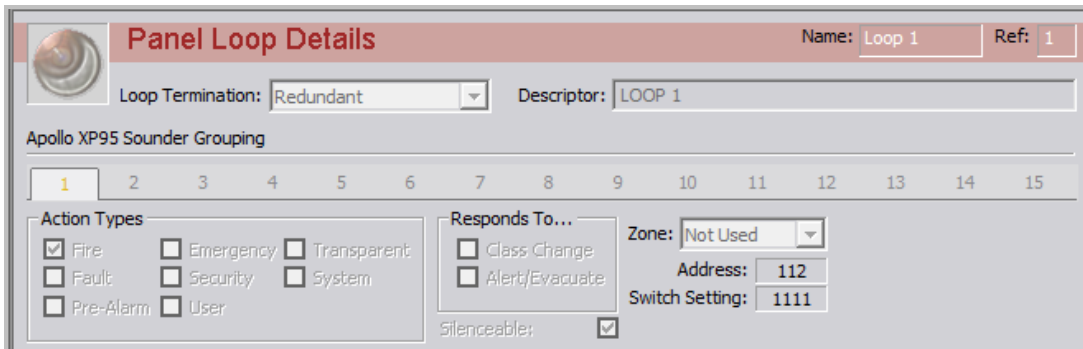

Figure 78: Panel Loop details

The Details Pane is a representation of the information available to the configuration of the Loop. It is displayed at the top portion of the Details Pane and is a non-editable, accurate representation of editable fields for a single loop.

The List View

Number	Name	Descriptor	Ref	Loop Termination
1	Loop 1	LOOP 1	1	Redundant

Figure 79: List view

The Loop List View appears immediately below the Loop Details View (as described above) and consists of a summary of all enabled loops on the current panel. As shown above, there are 2 loops enabled on this panel, entitled 'Loop 1' and 'Loop 2' respectively.

Editing

Double-clicking on any entry in the List View will open the editing dialog box for that particular loop.

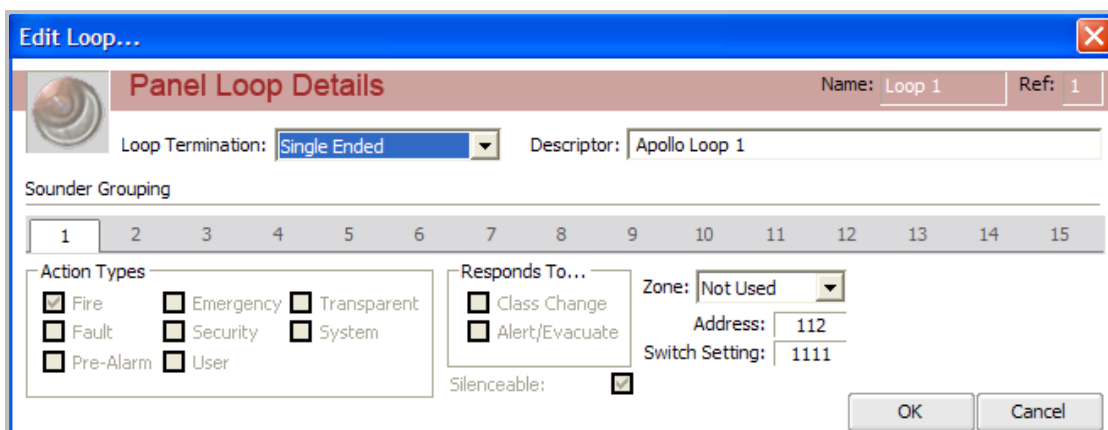

Figure 80: Panel Loop Details Window

The Loop editing dialog box consists of two types of fields:

1. Non-editable (informational) fields:
 - Name: The name of this loop,

- Ref: The reference number of this loop,
2. Editable fields:
- Loop Termination: Provides a combo box for the user to select the Loop Termination type for this loop,
 - Sounder Grouping: This set of fields allows the user to construct grouping strategies for this loop ***after a Zoning structure has been selected*** as shown below.

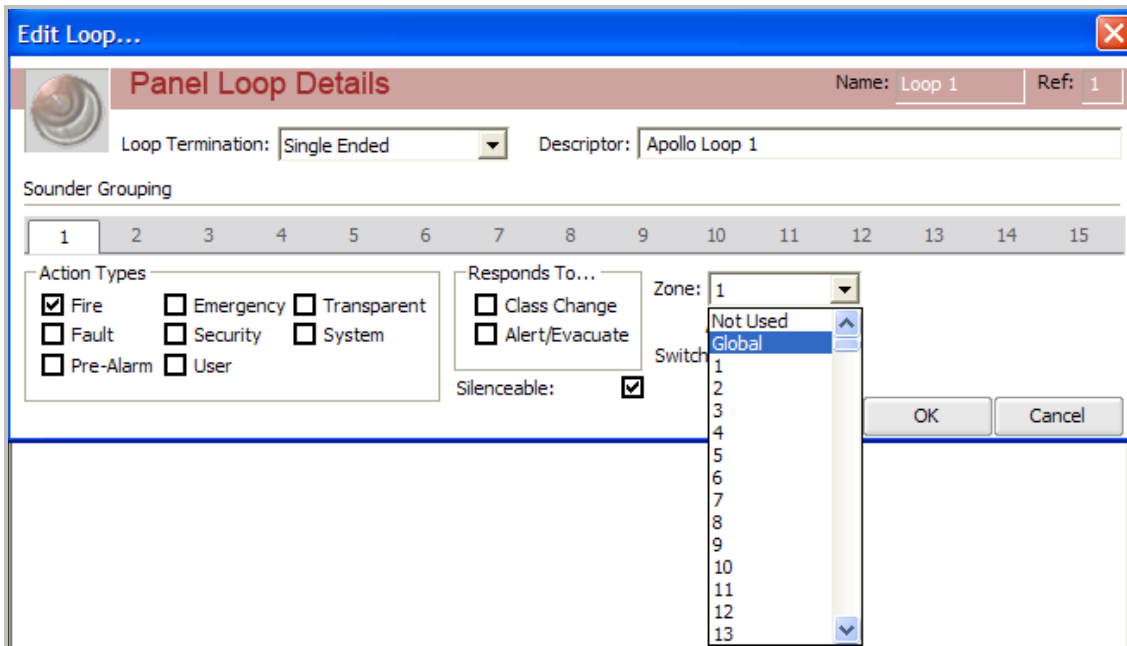

Figure 81: Panel Loop Details Zoning

8.1 Editing a Device without I/O

This section provides an outlook onto the generic method for editing a device (without I/O) on a loop.

While editing a device without I/O the user can be editing in either ‘Advanced’ or ‘Standard’ mode. Standard mode provides the user with the ability to edit the most common options for a device, while Advanced mode allows the user to edit extra options for that device.

The user can switch between Advanced and Standard mode by clicking on either the Advanced button, while in Standard mode, or the Standard button, while in Advanced mode.

The List View

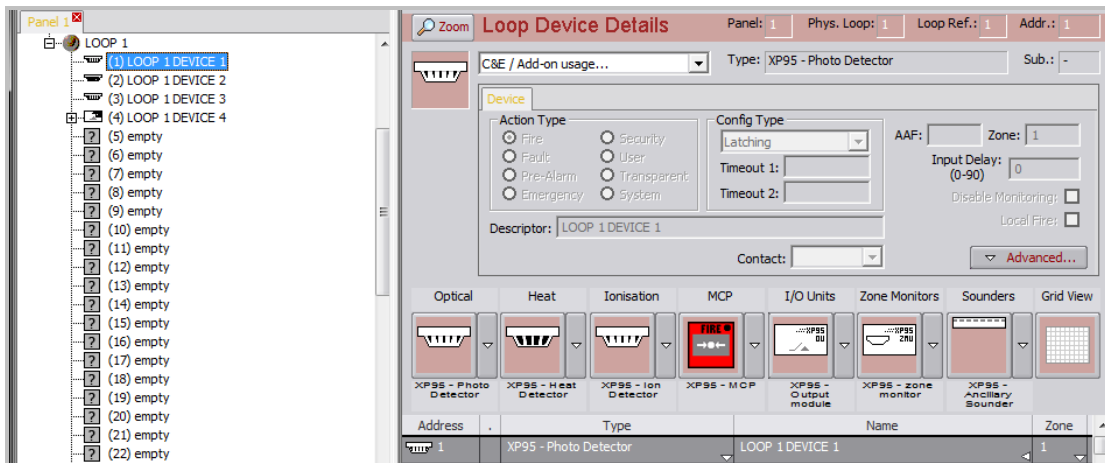

Figure 82: Device I/O Edit View

The above shows the initial screen for a loop, with one configured device (without I/O) at address 1 and the remainder of the loop set to ‘empty’.

Standard Mode

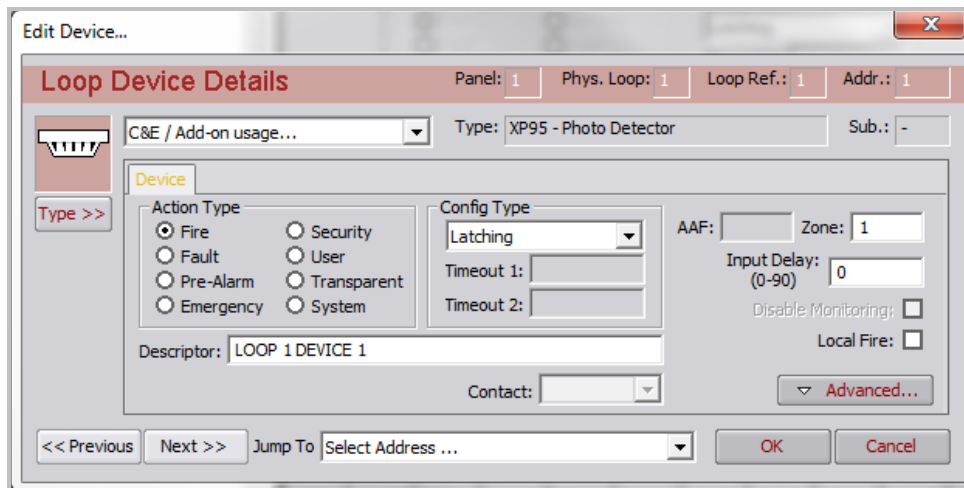

Figure 83: Loop Device Details Window

The device editing dialog box consists of two types of fields:

1. Non-editable (informational) fields:
 - Panel: The panel number this device belongs to,

- Phys. Loop: The physical loop number this device is attached to,
- Loop Ref.: The reference number of the loop this device is attached to,
- Addr.: The address of this device on the loop,
- Type: An application constructed string describing the type of device this is,
- Sub.: The sub-address we're currently working on; this field is not applicable to a device with no I/O,

2. Editable fields:

- Action Type: The user can select one Action Type to associate with this device,

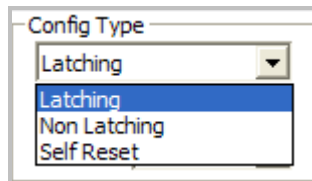

- Config Type: The user has the ability to select whether this device will exhibit behaviour consistent with the abilities of that device a Latching, Non Latching, Self Reset, General Purpose or Class Change input. Shown below is the expanded combo box with all available options.
- Configuration Timeout 1 & 2: The user can specify a timeout to be associated with the Config Type, if it requires it,
- Zone Number: Allows entering of a zone number between 1 and 999,
- Input Delay: The input delay, between 0 and 90 seconds,
- Disable Monitoring: Check this checkbox to disable monitoring of this device,
- Local Fire: Selected if Loop Device is not to call the brigade
- Descriptor: Allows the user to enter a 40 character descriptor describing this device,
- Cause & Effects and Add-On Usage: combo box, will list all cause & effects and Add-On entries that use this device.

Advanced Mode

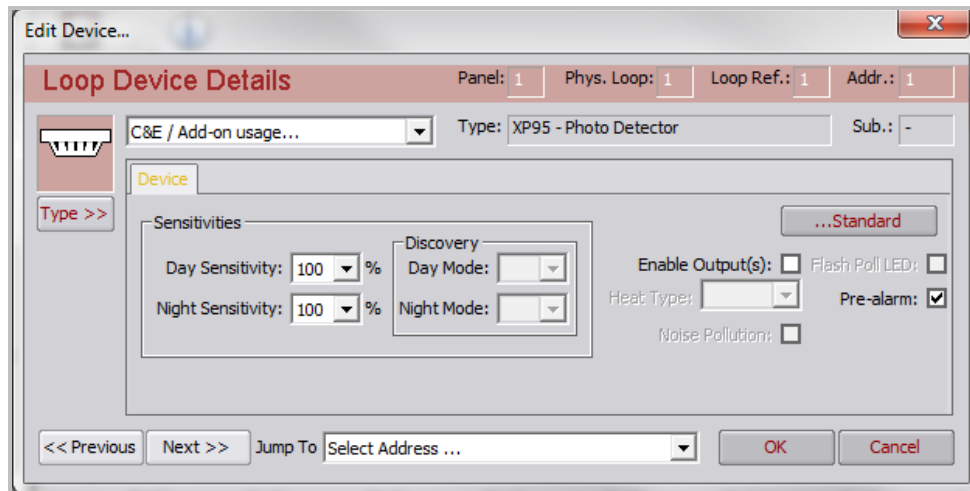

Figure 84: Loop Device Details Advanced View

The Advanced device editing options consists of editable and non editable fields depending on the device in use. For example the Day / Night Sensitivity – combo box for the user to select the sensitivity thresholds between 80 and 120%,

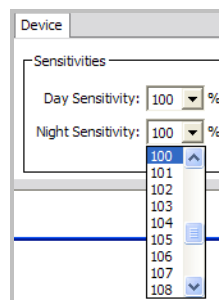

Figure 85: Device Day / Night Sensitivity Window

Others include

- Day Mode,
- Night Mode,
- Enable Output(s): If this checkbox is checked then any outputs on this device, which were previously hidden, will become visible; i.e. this would be most likely used to allow editing of a detector’s inherent output,
- Flash Poll LED: This checkbox is checked if the user wishes this device to flash its LED every time it is polled,
- Heat Type: This drop box allows the user to select the appropriate heat type for the current device
- Pre-alarm: Check this checkbox if the user would like pre-alarm reporting on this device.

8.2 Editing a Device with I/O

This section provides an outlook onto the generic method for editing a device (with I/O) on a loop.

The main distinction between editing devices with and without I/O is the extra level of abstraction between editing layers. That is, on devices without I/O the user will always assume that what they are editing is the device itself, whereas for devices with I/O the user must first select, via tab items, what they would like to edit, whether that be an input, an output or the device itself.

Similar to editing devices without I/O, while editing a device with I/O the user can be editing in either 'Advanced' or 'Standard' mode, while the 'Device' tab item is the currently selected tab item.

Following the user clicking on either an Input or an Output tab item, editing switches to a generic input or output editing scheme, as described in the following sections.

The List View

Address	Type	Name	Zone
1	XP95 - Photo Detector	LOOP 1 DEVICE 2	1
2	XP95 - Photo Detector	LOOP 1 DEVICE 2	1
3	XP95 - MCP	LOOP 1 DEVICE 4	1
4	XP95 - Output module	LOOP 1 DEVICE 5	1
5	XP95 - Loop powered beacon	LOOP 1 DEVICE 6	
6	XP95 - switch monitor	LOOP 1 DEVICE 7	1
7	S90 - Switch monitor unit	LOOP 1 DEVICE 8	1
8	XP95 - Three channel I/O module	LOOP 1 DEVICE 8	1

Figure 86: Editing a Device with I/O

The above is an example list view for a loop, showing configured devices (with I/O).

Note: That, unlike devices without I/O, following the 'Address' field we are presented with a '+' box which, when single clicked will expand the device to show its component inputs and/or outputs; as shown below.

4	XP95 - Output module	LOOP 1 DEVICE 5	1
	Output 1	LOOP 1 DEVICE 4 OUTPUT 1	1
5	XP95 - Loop powered beacon	LOOP 1 DEVICE 6	

Figure 87: Expanded Edit Window

Double clicking on this component I/O (Output1 in the example above) the "Edit Device" screen will be presented and the criteria for that output can be set. The same applies to the device itself.

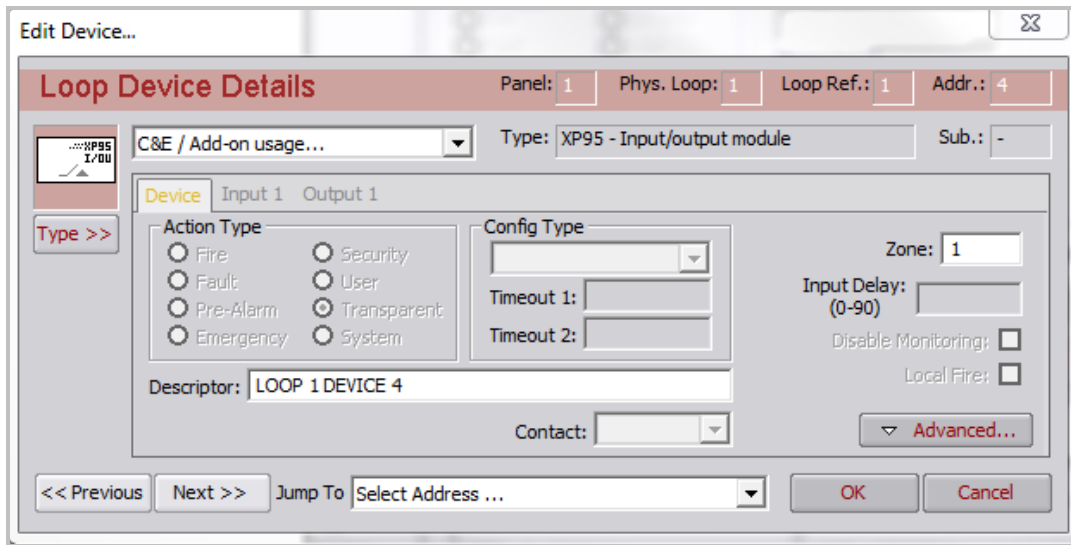



Figure 88: Loop Device Details Output Edit Window

 **Note:** That after clicking on the '+' box it changes into a '-' box which, when clicked will return the device to its collapsed state.

The Input Tab

Select the "Input X" Tab. The device input editing window consists of only editable fields:

- Action Type: The user can select one Action Type to associate with this device input,

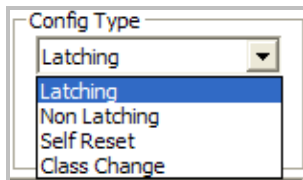

- Config Type: The user has the ability to select whether this device input will exhibit behaviour consistent with a Latching, Non Latching, Self Reset, General Purpose or Class Change input.
- Configuration Timeout 1 & 2: The user can specify a timeout to be associated with the Config Type,
- Contact: If applicable to the module and function the available options are available for setting whether this device input is N/O (Normally Open) or N/C (Normally Closed).
- Zone Number: Allows entering of a zone number between 1 and 999,
- Input Delay: The input delay, between 0 and 90 seconds,
- Disable Monitoring: Check this checkbox to disable monitoring of this device input,
- Local Fire: Selected if Loop Device is not to call the brigade
- Descriptor: Allows the user to enter a 40 character descriptor describing this device input

The Output Tab

Select the "Output 1" Tab.

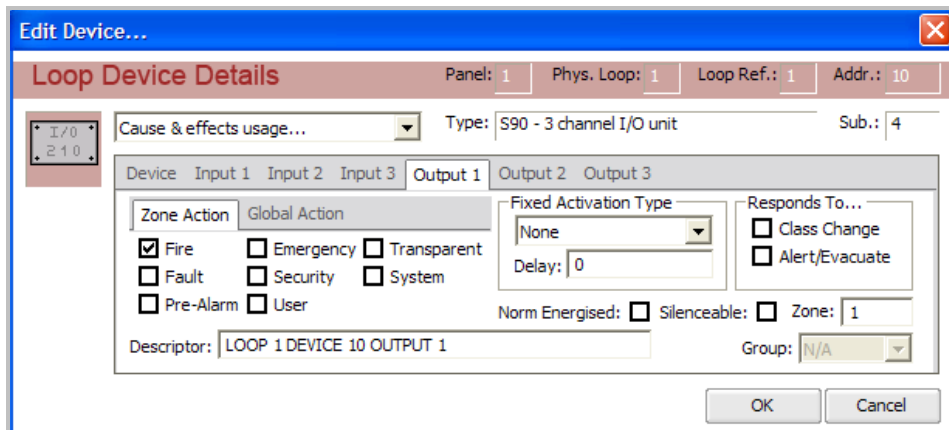
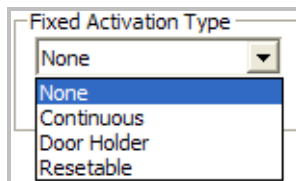

Figure 89: Loop Device Details Output Edit Window

The device output editing window consists of only editable fields:

- Global Action: The user can select one or more Global Action Type to associate with this device output. The user can switch between Global and Zone Actions by clicking on the appropriate tab item,
- Zone Action: The user can select one or more Zone Action Type to associate with this device output. The user can switch between Global and Zone Actions by clicking on the appropriate tab item.
- Responds To:
 - Class Change: Specifies that this device output will respond to a Class Change request,
 - Evacuate: Specifies that this device output will respond to an Evacuate request.
- Silenceable: This checkbox is checked to force this device output to become silenceable,
- Zone: Allows entering of a zone number between 1 and 999,



- Fixed Activation Type: shows the available Fixed Activation Types that can be assigned to this device output; Normal, Door Holder or Resettable,
- Fixed Activation Type Delay: Allows the user to enter a time delay to associate with the chosen Fixed Activation Type, if required,
- Norm Energised: This checkbox is checked to force this device output to behave as Normally Energised,

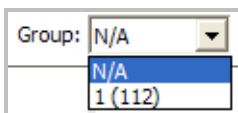

- Group: Allows the user to assign a group number to a device output. Shown below is an example of a group selection, where one group (Group 0) has been defined for the loop this device output is on,
- Descriptor: Allows the user to enter a 40 character descriptor describing this device output

The Device Menu

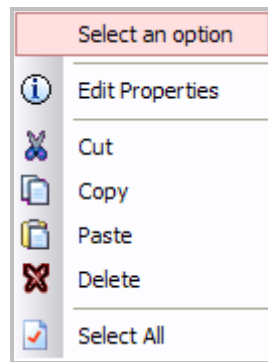

Figure 90: The Device Menu

The above is the menu that appears when a user right-clicks over a device in the device list view.

The menu provides the ‘normal’ Windows operating system clipboard operations to be performed on a device, or range of devices, as well as allowing the user to edit the device’s properties, by selecting the ‘Edit Properties’ item and subsequent sections, for a more in-depth discussion on clipboard operations in the device list view.

The Loop Menu

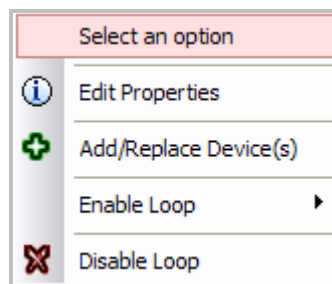

Figure 91: The Loop Menu

The Loop menu will appear once the user right-clicks over a device in the Tree View and is used for adding/editing devices and enabling/disabling loops.

The above is the default loop menu, with the ‘Enable Loop’ item available; i.e. the panel in question can have multiple loops and not all loops have been enabled. On single loop panels this item is unavailable.

There is also an option to Add/Replace Device(s), which provides a shortcut method for users to edit and/or add devices to the current loop.

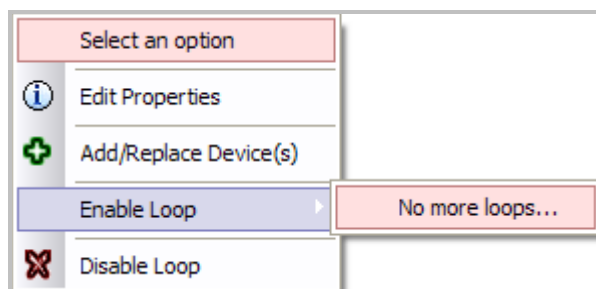

Figure 92: Enabling Loops

The above is the menu previously described, but with the ‘Enable Loop’ item selected and expanded.

8.3 Devices

This section covers the appearance and programmability options, with regards to devices on a loop.

As introduced in the preceding points, devices can be edited in either List View mode or Grid View mode, which will be explained more fully in the sections to follow.

The methods with which devices are edited or manipulated remain the same between the two modes, with the only differences being, primarily, the way the devices (and associated I/O) are displayed to the user; i.e. in List View mode the information is displayed as a list, containing text fields, while in Grid View mode the information is displayed in a graphical manner, with minimal clutter.

8.3.1 Selecting

When selecting devices in the Device List View, all 'normal' Windows operating system rules and procedures, with regards to selection of objects in a list control, apply.

Address	Type	Name	Zone
1	XP95 - Photo Detector	LOOP 1 DEVICE 1	1
2	XP95 - Photo Detector	LOOP 1 DEVICE 2	1
3	XP95 - MCP	LOOP 1 DEVICE 3	1
4	XP95 - Output module	LOOP 1 DEVICE 4	1
4.1	Output 1	LOOP 1 DEVICE 4 OUTPUT 1	1

Figure 93: Device Selection screen

The above shows an example of multiple, non-sequential, selections of devices 1 and 3. As per normal Windows operating system procedures a multiple selection can be accomplished by holding down the CTRL key while clicking on different devices with the left mouse button.

Address	Type	Name	Zone
1	XP95 - Photo Detector	LOOP 1 DEVICE 1	1
2	XP95 - Photo Detector	LOOP 1 DEVICE 2	1
3	XP95 - MCP	LOOP 1 DEVICE 3	1
4	XP95 - Output module	LOOP 1 DEVICE 4	1
4.1	Output 1	LOOP 1 DEVICE 4 OUTPUT 1	1

Figure 94: Device Selection screen

The above shows an example of a sequential selection of devices 1 and 2. As per normal Windows operating system procedures, a multiple sequential selection can be accomplished by firstly selecting the first device of a sequence and then selecting the last device in the sequence, while holding down the SHIFT key on the keyboard.

8.3.2 Drag & Drop

The Device List View supports the dragging and dropping of devices from the device group lists.

The user first selects the required device from the device group list and then, while holding the left mouse button down, ‘drags’ the device, which now has its graphical representation ‘attached’ to the mouse cursor, over the Device List View. As the mouse cursor moves over the Device List View, the selected devices, or addresses, change colour, to notify the user as to where the new device will be placed when dropped. To drop the device, and replace all selected devices or addresses, the user simply has to release the left mouse button over any of the selected devices or addresses.

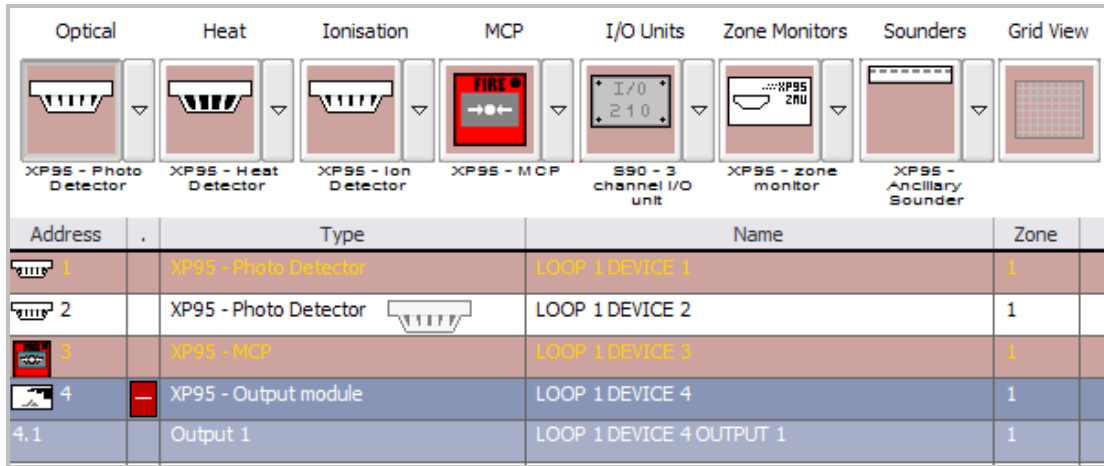

Figure 95: Drag and Drop of device

The above, shows an example of a user dragging a device over a non-sequential selection of addresses. The above figure is the same as that shown previously except that the selection colour has changed, to notify the user that those addresses have become the target for the drop operation.

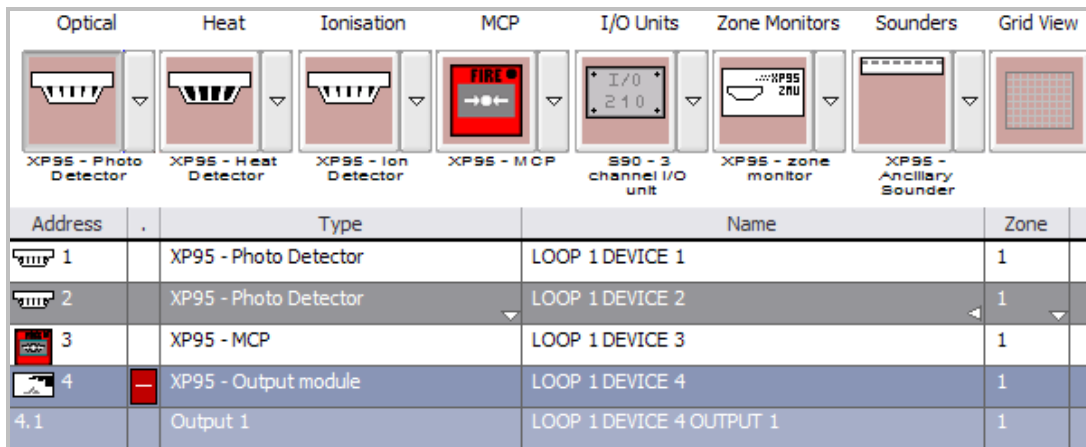

Figure 96: Device configured

The above is the result of releasing the left mouse button and executing the drop operation. The highlighted address now has the dragged device assigned to it.

Effectively, the user has, with one click, added devices to the loop in a non-sequential order.

These same operations apply to sequential selections as well; the Windows application makes no distinction between the two.

The List Menu

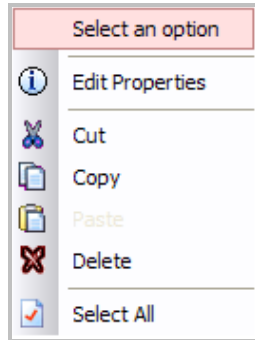

Figure 97: The List Menu

The above is the menu that appears when a user right-clicks over a device in the device list view.

The menu provides the ‘normal’ Windows operating system clipboard operations to be performed on a device, or range of devices, as well as allowing the user to edit the device’s properties, by selecting the ‘Edit Properties’ item; and subsequent sections, for a more in-depth discussion on clipboard operations in the device list view.

The Grid View

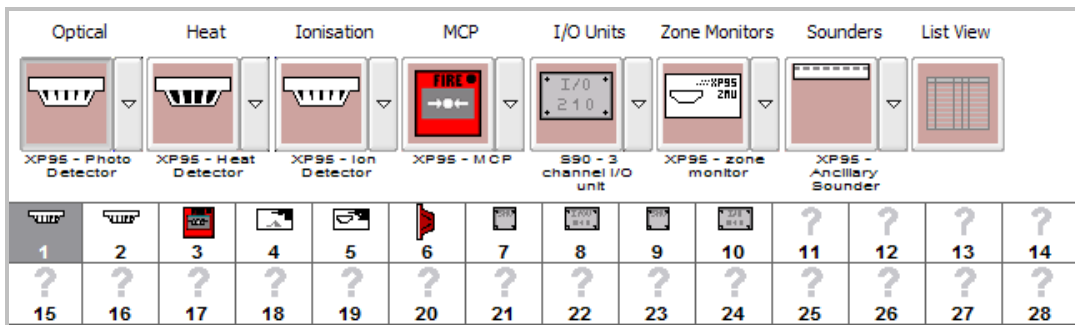

Figure 98: Grid view of devices

The Device Grid View appears immediately below the Device Details View while in Grid View mode, and consists of a purely graphical representation of all loop device addresses, whether those addresses are currently occupied or not; i.e. all addresses are shown, whether there is a device assigned to that address or not. In the above, if there are no devices assigned to the loop, addresses currently ‘empty’, is signified by a ‘?’ graphic in each address ‘slot’.

Double-clicking on any non-empty (address with a device assigned to it) entry in this grid will open the editing dialog box for that particular device.

8.3.3 Selecting

When selecting devices in the Device Grid View, all ‘normal’ Windows operating system rules and procedures, with regards to selection of objects in a list control, apply. That is, the same operations that can be performed in a list control can be performed in this grid control.

As per normal Windows operating system procedures a multiple selection can be accomplished by holding down the CTRL key while clicking on different devices with the left mouse button.

As per normal Windows operating system procedures, a multiple sequential selection can be accomplished by firstly selecting the first device of a sequence and then selecting the last device in the sequence, while holding down the SHIFT key on the keyboard.

8.3.4 Drag & Drop

The Device Grid View supports the dragging and dropping of devices from the device group lists.

The user first selects the required device from the device group list and then, while holding the left mouse button down, 'drags' the device, which now has its graphical representation 'attached' to the mouse cursor, over the Device Grid View. As the mouse cursor moves over the Device Grid View, the selected devices, or addresses, change colour, to notify the user as to where the new device will be placed when dropped. To drop the device, and replace all selected devices or addresses, the user simply has to release the left mouse button over any of the selected devices or addresses.

8.3.5 The Grid Menu

The menu provides the 'normal' Windows operating system clipboard operations to be performed on a device, or range of devices, as well as allowing the user to edit the device's properties, by selecting the 'Edit Properties' item.

8.3.6 The Device Explorer

The device explorer appears once the user selects 'Add/Replace Devices' from the sub-menu that appears when they have clicked on the Devices button, as part of the Details Pane Toolbar, or from the Loop Menu (right-clicking over a device/loop in the tree view). The device explorer appears.

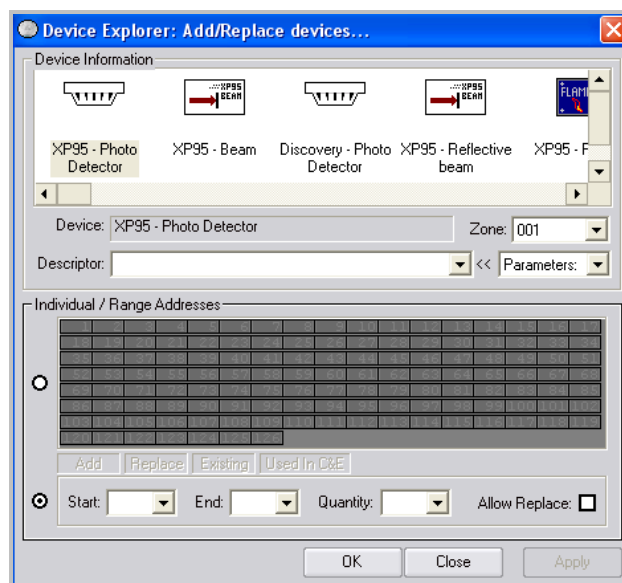

Figure 99: Multiple Device addition

The method of selecting devices changes depending on the state of the radio button, to the left.

The above shows the 'range' method for selecting devices, whereby a range is flagged by either specifying a start and end address, via the drop boxes, or a quantity, as an offset from the start address. The Allow Replace checkbox signifies that, should there already be a device at an address in the specified range, it will be overwritten by the new device.

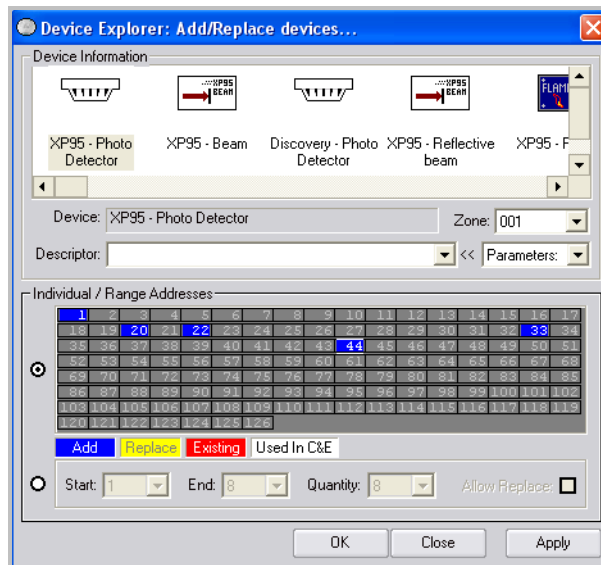

Figure 100: Add/Replace Device

The above shows the ‘individual’ method for selecting devices, whereby the user has full control over which addresses are to be selected, whether they be contiguous or not. The colour scheme is as follows;

- Add (Blue): Clicking on an empty address will mark it as blue; i.e. we wish to add a device,
- Replace (Yellow): Clicking on an address that already has a device on it will mark it as yellow, to signify that the device is to be replaced,
- Existing (Red): Address marked in red signify addresses that already contain devices,
- Used In C&E (White): These addresses signify that the device is used in one or more cause and effect entries and cannot be removed or replaced.

The device to be placed at the specified addresses is selected via the graphical selection control at the top of the dialog box. The user may also specify the zone number and a descriptor for each device, via the adjacent controls;

- The zone number is selectable via the zone drop box,
- The descriptor can either be typed in directly, into the descriptor control, or selected from its drop list, which holds the previous descriptors used in the device explorer
- The Parameters drop list holds a selection of textual ‘flags’ which, when applied to the selected addresses, changes into its corresponding meanings; i.e.
 - Panel No. (%P): this is replaced with the actual panel number,
 - Loop No. (%L): this is replaced with the actual loop number,
 - Device No. (%D): this is replaced with the current device address,
 - Zone No. (%Z): this is replaced with the zone number as specified via the zone drop box,
 - Counter (%C): this is replaced with the current value of a counter which begins at 1 and is incremented each time a device is placed onto the loop, in the current device explorer session.

Clicking 'OK' will close the dialog box and perform the requested actions, while 'Close' will simply close the dialog box and do nothing. Clicking 'Apply' will perform the required actions and then re-open the device explorer dialog box.

8.4 Device Types

There are a number of devices and device types available, to the user, for assigning to addresses on a loop.

The available devices are organised into logical groups, to form the 'group lists', which are represented in the Group List Toolbar.

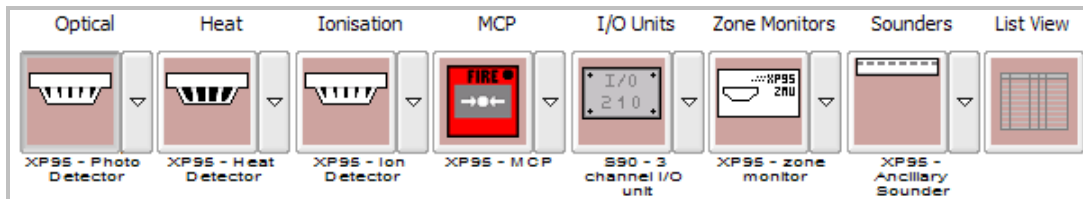

Figure 101: Device Types

The Group List Toolbar is made up of eight buttons, with seven of those buttons allocated to a distinct, logical device-type group list.

The only non-tool in the Group List Toolbar is the Grid View button, whose purpose is to toggle between the Device List View and Device Grid View.

The group list buttons reflect the currently selected device type in their device list, by appearing with a graphic of the currently selected device on their button faces. Each group list button has text below it, to let the user know which logical group of devices this button can 'create'.

To select a device for an operation, like a drag and drop, simply click the required device type.

To change the currently selected device in a particular group, the user must click on the button to the right of the group list button (the button with the downward pointing arrow chevron) and a submenu will appear, showing all of the available device types this group list button holds. The user then simply selects the required device type from this menu and this then becomes the currently active device type for this group list button.

Device Groups

The following are the sub-menus that appear when a user has clicked on one of the "Device" group list buttons. To change the currently active device type for the group, the user needs to select the appropriate item from the menu. Once selected "click and drag" the device into the configuration.

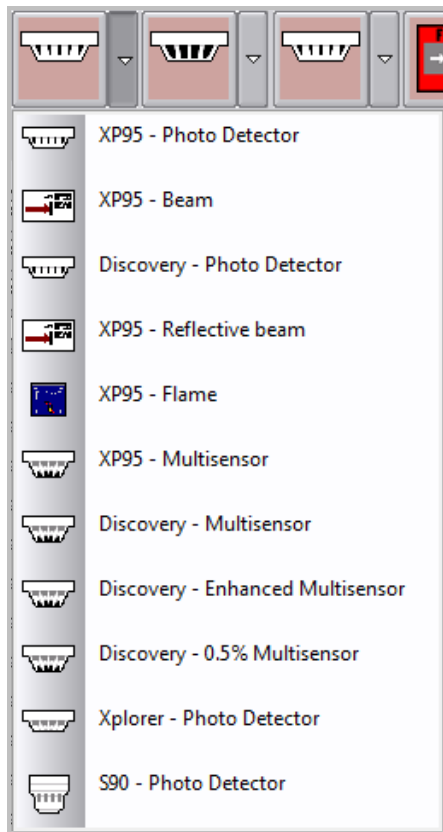

XP95 - Photo Detector
 XP95 - Beam
 Discovery - Photo Detector
 XP95 - Reflective beam
 XP95 - Flame
 XP95 - Multisensor
 Discovery - Multisensor
 Discovery - Enhanced Multisensor
 Discovery - 0.5% Multisensor
 Xplorer - Photo Detector
 S90 - Photo Detector

Optical Range

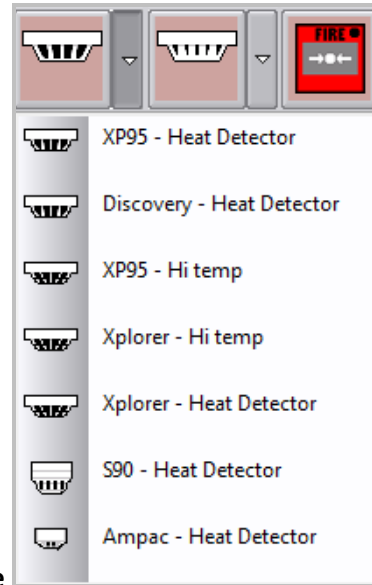

XP95 - Heat Detector
 Discovery - Heat Detector
 XP95 - Hi temp
 Xplorer - Hi temp
 Xplorer - Heat Detector
 S90 - Heat Detector
 Ampac - Heat Detector

Heat Range

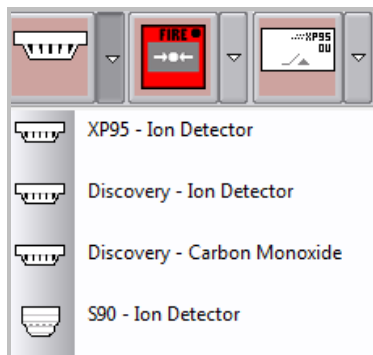

XP95 - Ion Detector
 Discovery - Ion Detector
 Discovery - Carbon Monoxide
 S90 - Ion Detector

Ionisation range

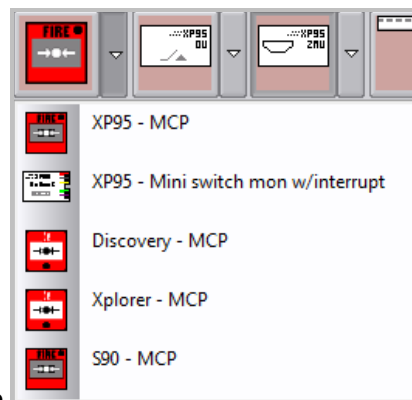

XP95 - MCP
 XP95 - Mini switch mon w/interrupt
 Discovery - MCP
 Xplorer - MCP
 S90 - MCP

MCP range

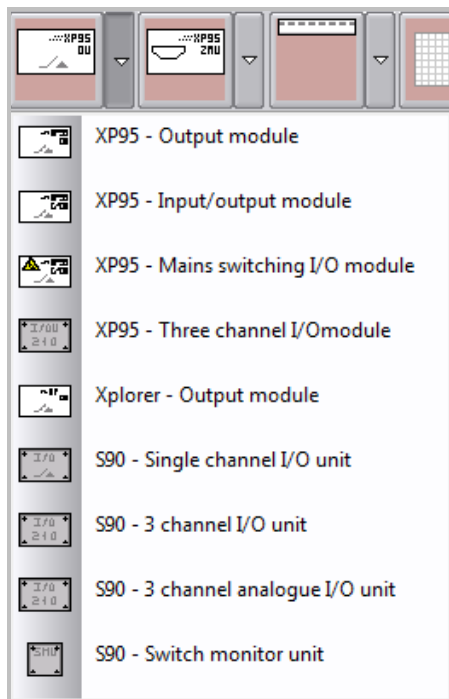

I/O range

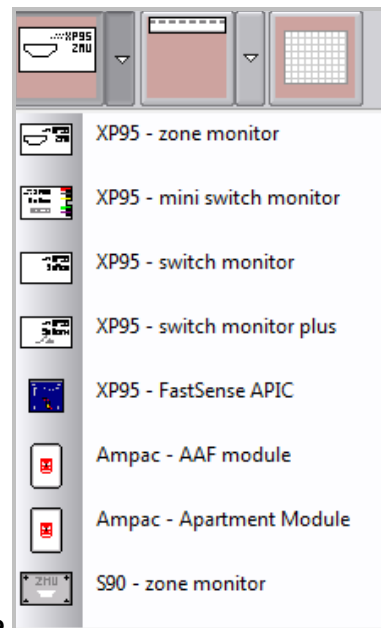

Monitor Range

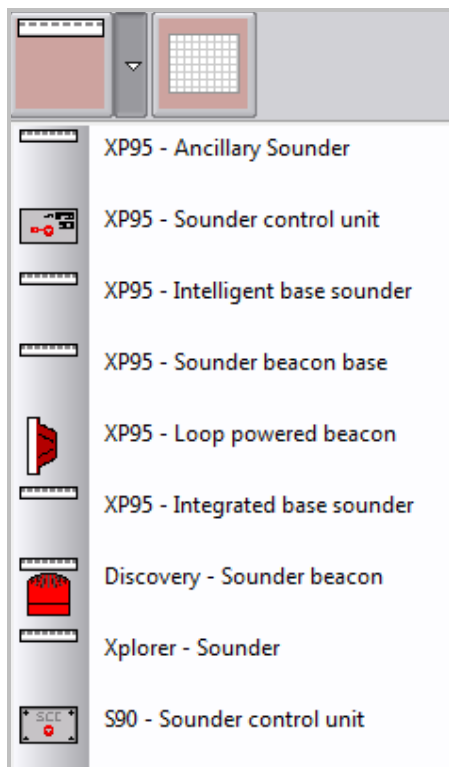

Sounder Range

Selecting List View

Address	.	Type	Name	Zone
? 1		-	empty	
? 2		-	empty	
? 3		-	empty	

Places the selected device into

an information list

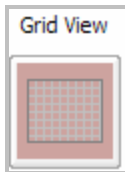
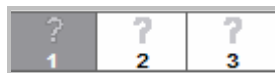
Selecting Grid View

as shown in Figure 111. Places the selected

device into a pictorial grid

The “user” selects the preferred view

8.5 Apartment Module

The Apartment Module (AM) is a loop powered addressable device that helps reduce the costly consequences of an unwanted alarm

An occupant is able to silence a local audible warning, activated by a local smoke detector, and allowing a preset time to investigate the cause of the alarm. Local smoke detectors can be connected directly to the AM (conventional) or connected to the addressable loop (addressable) and assigned to the AM.

The local smoke detector is self resetting and if the smoke clears, then the system will return to normal. If the smoke remains, then the local audible warning will resound at the expiry of the preset timeout. A local smoke detector will NOT cause a general fire alarm.

The fire system will go into general fire alarm (thus calling the brigade) if:

- Any thermal detector has gone into alarm (conventional connected to the AM or addressable connected to the addressable loop)
- Any smoke detector in common areas has gone into alarm
- Any call point activated

ConfigManager is programmed to identify the associations of AM’s with the local smoke detectors (conventional and addressable) and adjustment of the “Investigation” period.

8.5.1 Configuring an Apartment Module

Using Loopmaster select AMPAC Apartment Module from the Zone Monitor Drop down Box and Drag and Drop on the appropriate loop address.

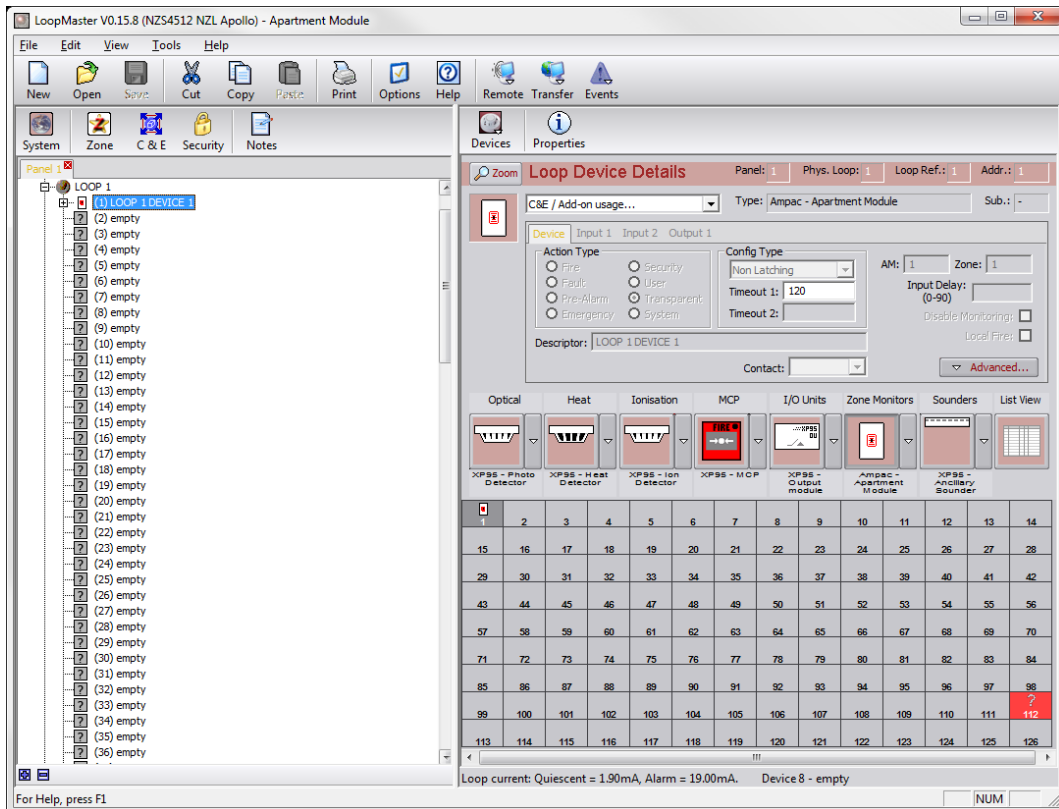
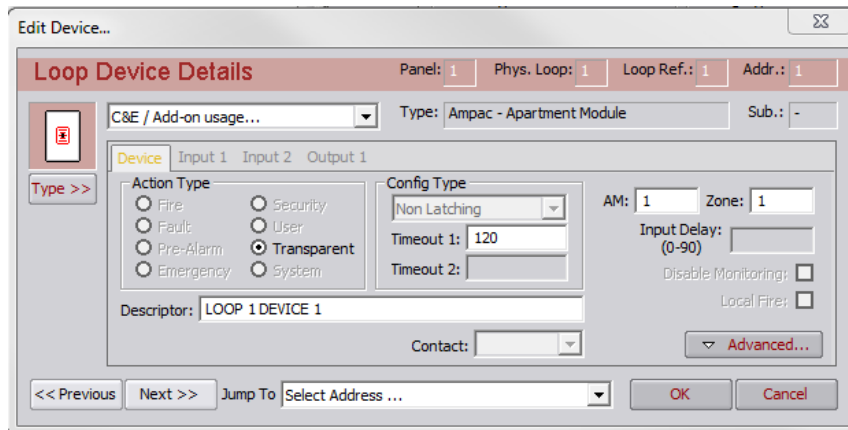

Figure 102: Apartment Module Address 1



Time Out 1 is the investigation time and can be set in a range from 0 – 120Sec

Next will be the addition of Smoke and Heat Detectors that will be associated with the Apartment module.

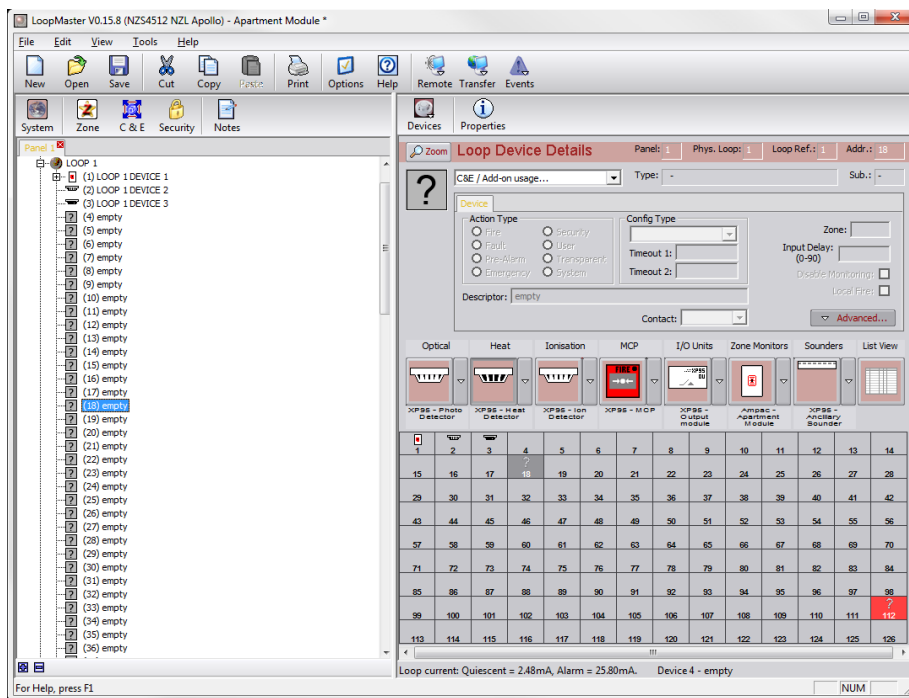

Figure 103: Smoke and Heat Detector added to address 2 & 3

Double clicking the Smoke or Heat detector will bring up the following screen where you will select which AM the detectors are associated to.

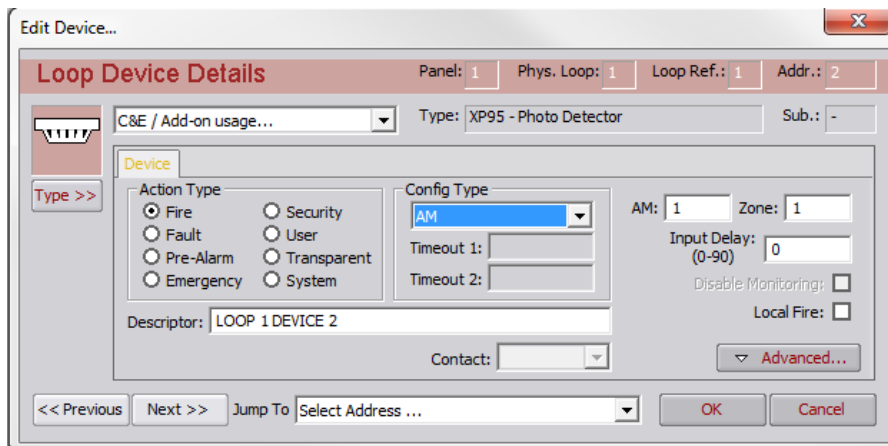

Figure 104: Photo Detector Associated with Apartment Module 1.

This completes the zone section of setting up an Apartment Module.

The AM device can be used as a C&E input in LoopMaster where selection is available to trigger off a LOCAL ALARM or FIRE signal associated with the AM device. The AM C&E input signal can be logically combined with other C&E inputs to activate C&E outputs. The C&E outputs can control tones generated by an attached EV3000 or tone generator to annunciate the local alarm or evacuation tones as required. Note when using the AM device in C&E, the AM FIRE condition activates only when a ‘non-smoke’ fire signal is received from the AM device zone circuit or an AM group associated non-smoke alarm calling loop device. The AM LOCAL ALARM condition activates only when a ‘smoke’ alarm signal is received from the AM device zone circuit or an AM group associated loop smoke detector.

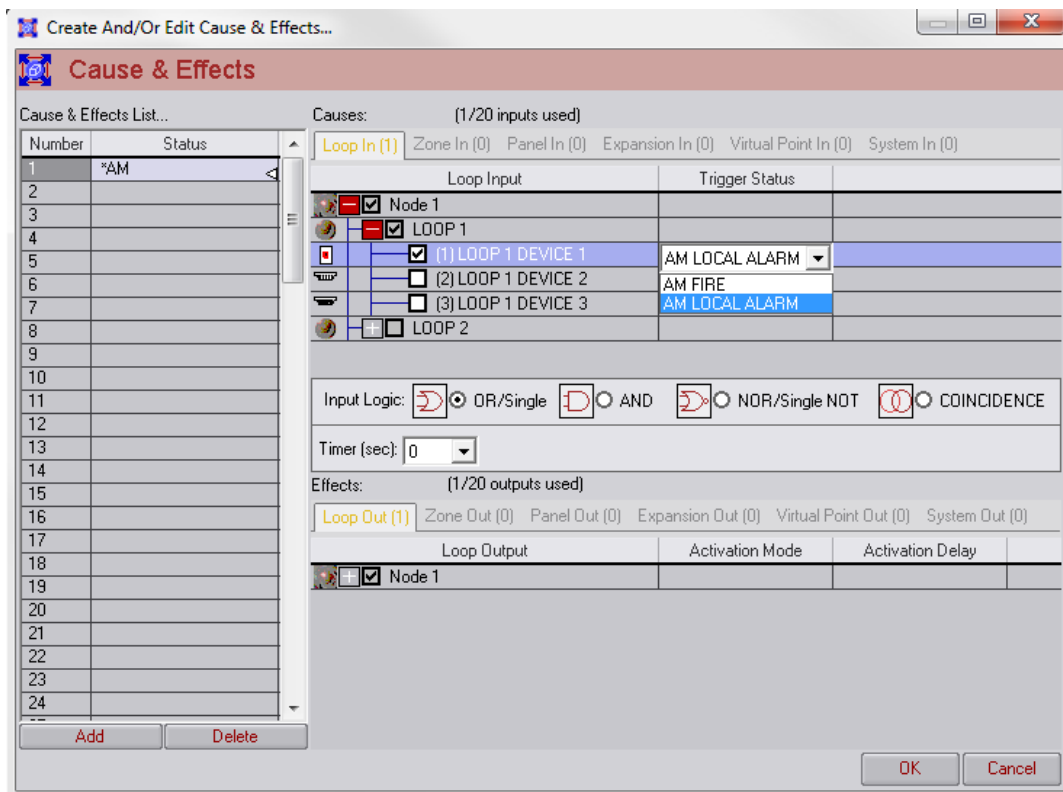

Figure 105: AM LOCAL ALARM or AM FIRE Selection

8.5.2 Configuring a Cause and Effect for an Apartment Module

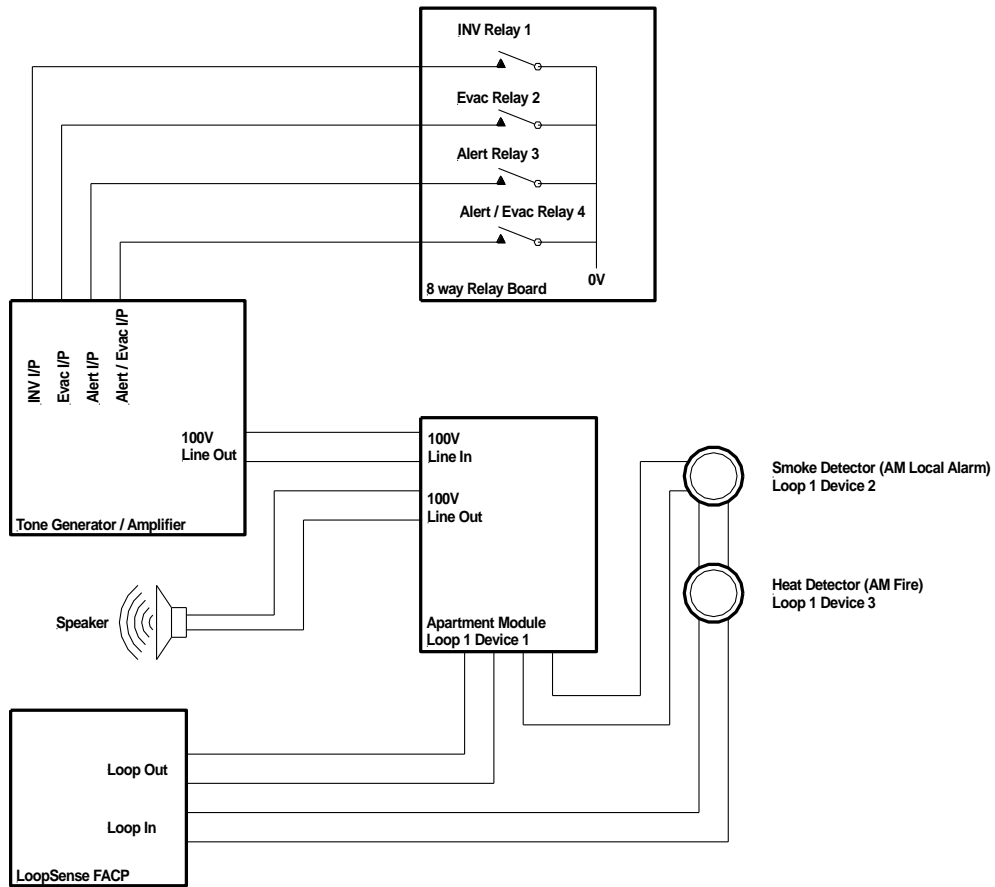
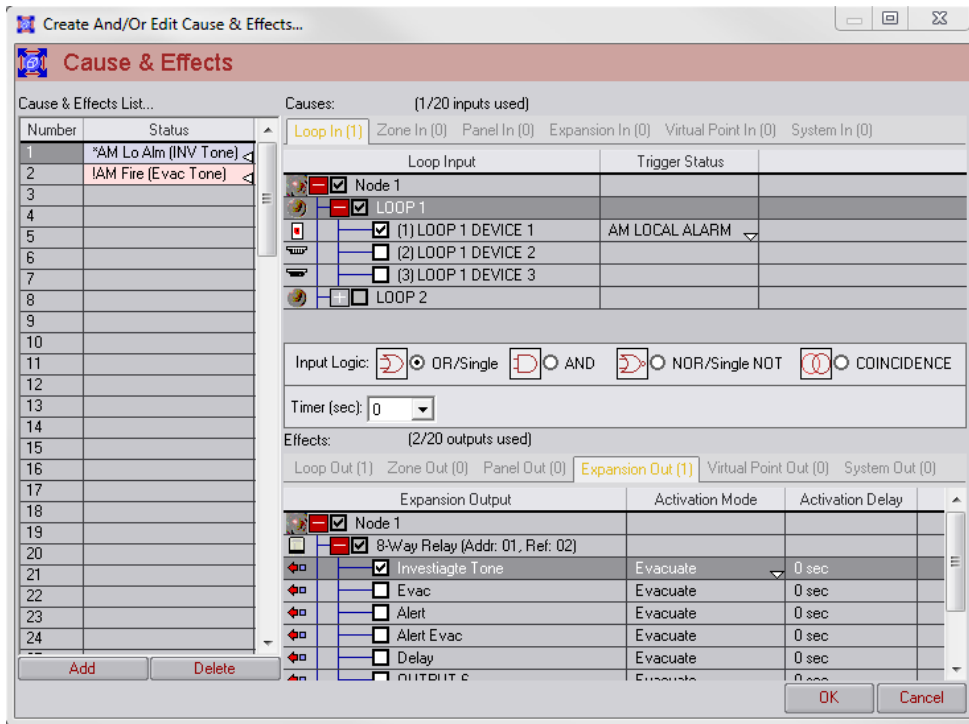

Figure 106: Apartment Module Block Diagram

Creating an AM LOCAL ALARM Cause and Effect. Eg Turn on the Local Alarm investigate tone.



As we can see in the above example if the Apartment module is in AM LOCAL ALARM turn on Relay one. Relay one is used to switch an input to the Tone Generator which in turn will provide and Investigate tone to switch thru the Apartment Module

Creating an AM Fire Cause and Effect. Eg Turn on the Evacuation Tone

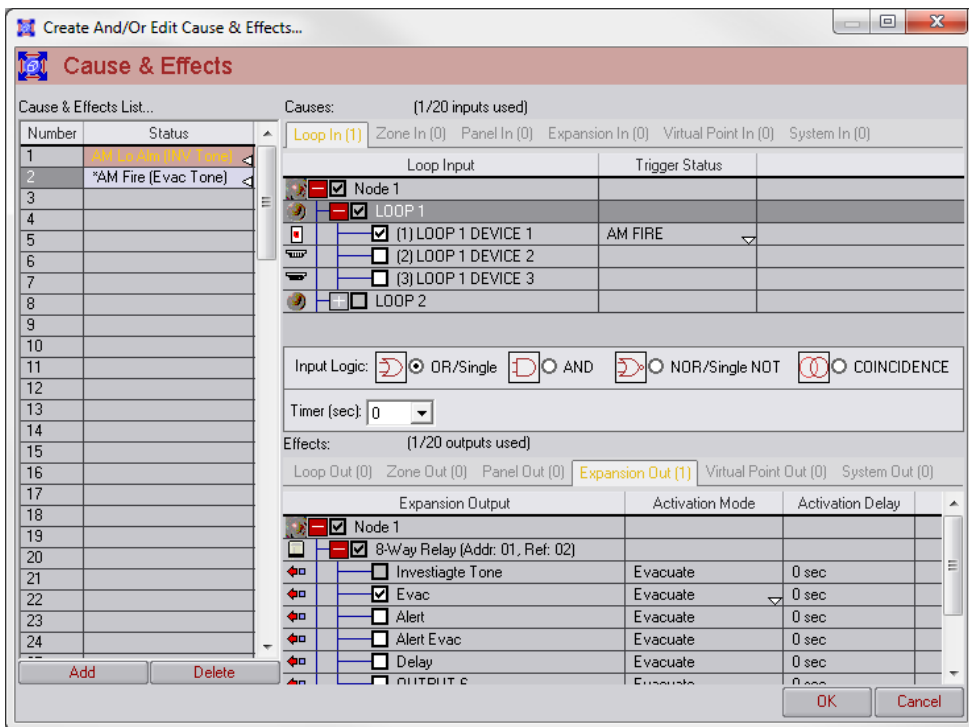

As we can see in the above example if the Apartment module is in AM FIRE turn on Relay two. Relay two is used to switch an input to the Tone Generator which in turn will provide and Evac tone to switch thru the Apartment Module

9 Panel Add-Ons

Each panel can have a maximum number of 30 or Add-On's attached to it at any one time.

The available Add-Ons are:

- **SmartTerminal**
- NZ LED Index

The Tree View

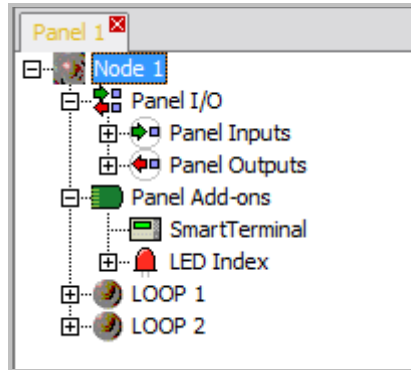

Figure 107: The Tree View of Add-Ons

The above, shows the Tree View with the Panel Add-On tree expanded to show the available Add-On's which are, themselves, expandable once the user has manually added one to the panel configuration.

Adding or removing an Add-On is a simple matter of right-clicking over the desired type and selecting the appropriate item from the resultant menu; this is described further in the relevant sections to follow.



Note: That each panel can have a maximum of 30 Add-On's in total, which can be made up of any combination of types. Apart from the SmartTerminal each type, in itself, can have a maximum of 15 addressable Add-On's; the SmartTerminal can have a maximum of 30.

Explanations for the different types of Add-Ons will be discussed in the following sections.

The Details View

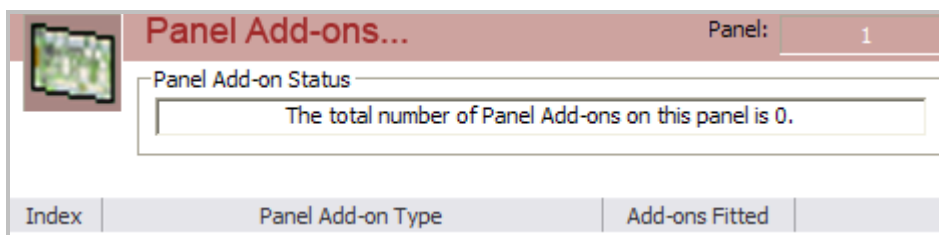

Figure 108: Panel Add-On Detail View

The above is displayed as part of the Details Pane representation of the information available to the panel-wide configuration of its Add-On modules. It is displayed at the top portion of the Details Pane and informs the user of the currently selected panel and the total number of Add-On's currently configured for this panel.

The List View

Index	Panel Add-on Type	Add-ons Fitted
1	SmartTerminal	1
2	LED Index	1

Figure 109: Panel Add-Ons List View

The panel Add-On module List View appears immediately below the Add-On module Details View and consists of a summary of all available Add-On modules.

9.1 SmartTerminal

The *SmartTerminal* is primarily used as a remote ‘terminal’, allowing users to view panel statuses and interact, to some extent, with the panel, while not being physically at the main panel’s LCD and keypad.

An in-depth explanation of the *SmartTerminal* falls out of the scope of this document – a description on how it can be configured via the Windows application follows.

The Tree View

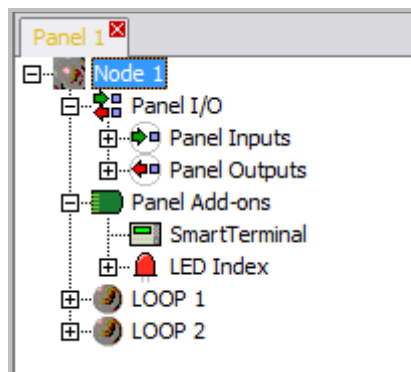

Figure 110: SmartTerminal Window

Here is shown the expanded view of the *SmartTerminal* Add-On type. In the case above the panel in question has 1 *SmartTerminal* assigned to it, entitled ‘Panel Add-On 1’

Selecting one of these Add-On’s will update the Details Panel with the respective module’s information, while double-clicking on the Add-On will open its editing dialog box.

Note: That it is possible to have a maximum of 30 *SmartTerminal* Add-On’s per panel, however, this value will reduce as other Add-On types are added (the entire panel can have a maximum of 30 Add-On’s, of any type, at any one time).

The Details View

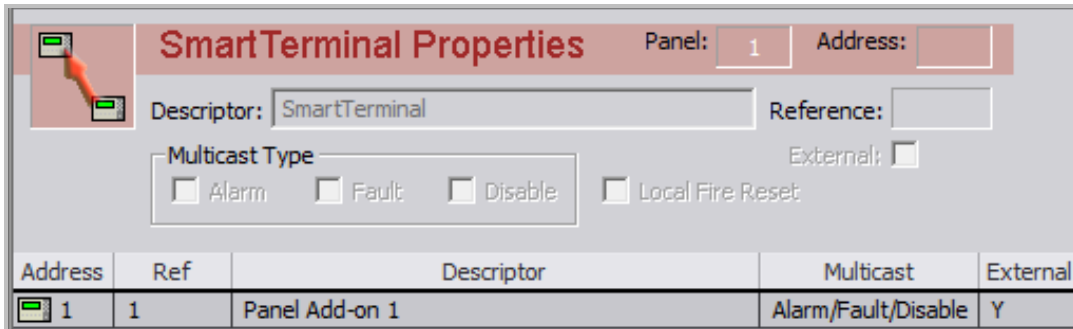

Figure 111: Smart Terminal Properties

The above is displayed as part of the *SmartTerminal* Details Pane representation of the information available to the configuration of the data. It is displayed at the top portion of the Details Pane and is a non-editable, accurate representation of editable fields for a *SmartTerminal*.

The List View

Address	Ref	Descriptor	Multicast	External
1	1	Panel Add-on 1	Alarm/Fault/Disable	Y

Figure 112: The List View

The *SmartTerminal* Add-On List View appears immediately below the *SmartTerminal* Add-On Details View and consists of a summary of all available *SmartTerminal* Add-On's assigned to the current panel. In the above 1 Add-On *SmartTerminal* s assigned to this panel, entitled 'Panel Add-On 1'.

Double-clicking on an entry in the list opens the editing dialog box for that particular *SmartTerminal*.

Editing

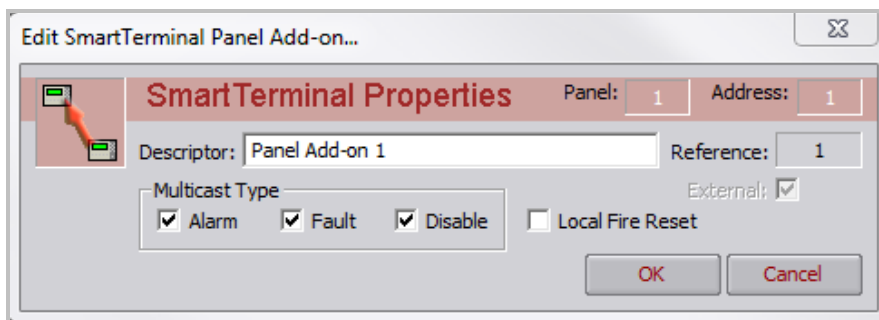

Figure 113: Smart Terminal Edit Screen

The *SmartTerminal* Add-On editing dialog box consists of two types of fields:

1. Non-editable (informational) fields:
 - *Panel*: The panel number this module belongs to,
 - *Address*: The hardware address of this particular module; addresses can be in the range of 1 to 30,
 - *Reference*: The reference number of this module

2. Editable fields:

- *Multicast Type*: The user can select one or more Multicast Types for this module to process,
- *External*: If this checkbox is checked then this Add-On is to be used on the external bus,
- *Descriptor*: Allows the user to enter a 40 character descriptor describing this Add-On,
- *Local Fire Reset*: Smart Terminal is configurable to perform a global reset by default or a Local Fire Reset which only resets the Local (non-brigade calling) Fire inputs/devices

Menu

Right-clicking on the *SmartTerminal* Add-On parent item from the Tree View opens the menu

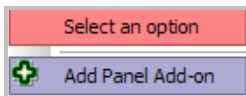

. It contains an option to add a panel Add-On to the panel.

Right-clicking on an existing *SmartTerminal* Add-On from the Tree View opens the menu,

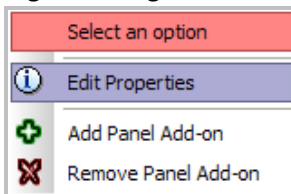

It contains an option to add another or remove the current Add-On or via the 'Edit Properties' option to open the Add-On editing dialog box.

9.2 LED Index

The LED Index makes available 32 mappable zone indicators to the panel.

The first 4 LED's of the first LED Mimic Board are defaulted to:

1. Fire
2. DBA
3. Defect
4. Normal

The remaining 28 LED's can be assigned to any Zone configured within the Panel.

An in-depth explanation of the LED Index falls out of the scope of this document – a description on how it can be configured via the Windows application follows.

The Tree View

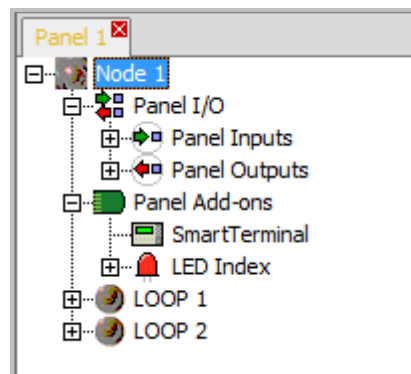



Figure 114: 32 Zone Indicator Selection

The above shows the expanded view of the LED Index Add-On type. In the case above the panel in question has 1 x LED Index Card assigned to it, entitled 'Panel Add-On 1'.

Selecting one of these Add-Ons will update the Details Panel with the respective information, while double-clicking will open its editing dialog box

 **Note:** That it is possible to have a maximum of 15 x LED Mimic Card Add-Ons per panel, however, this value may reduce as other Add-On types are added (the entire panel can have a maximum of 30 Add-Ons of any type, at any one time).

The Details View

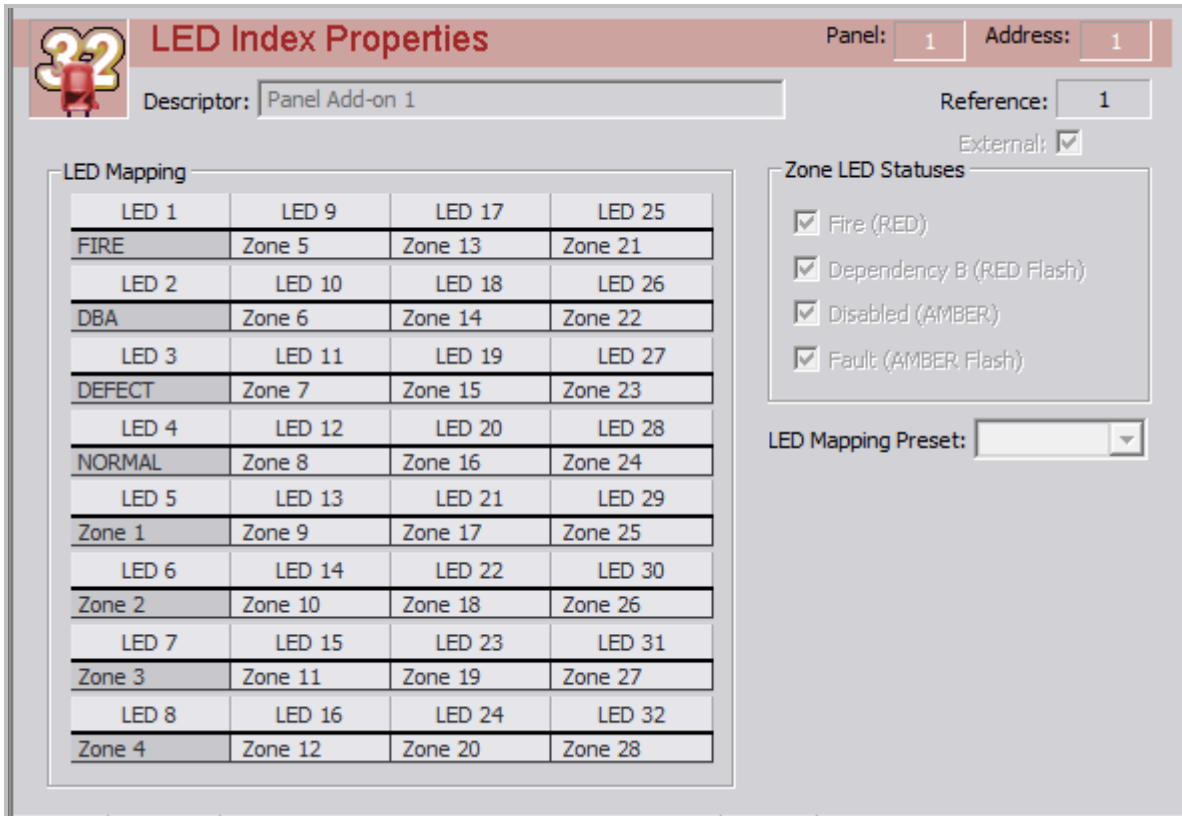

Figure 115: 32 Zone Properties

The above is displayed as part of the Details Panel representation of the information available to the configuration of the LED Mimic Board data. It is displayed at the top portion of the Details Panel and is a non-editable, accurate representation of editable fields for a 32 Zone Indicator Card.

The List View

Address	Ref	Descriptor	External
 1	1	Panel Add-on 1	Y

Figure 116: List View

The LED Index Add-On List View appears immediately below the 32 Zone Indicator Card Add-On Details View (as described above) and consists of a summary of all available 32 Zone Indicator Card Add-On assigned to the current panel. The above shows 1 x Add-Ons assigned to this panel, entitled 'Panel Add-On 1'

Double-clicking on any entry in this list will open the editing dialog box for that particular Add-On.

Editing

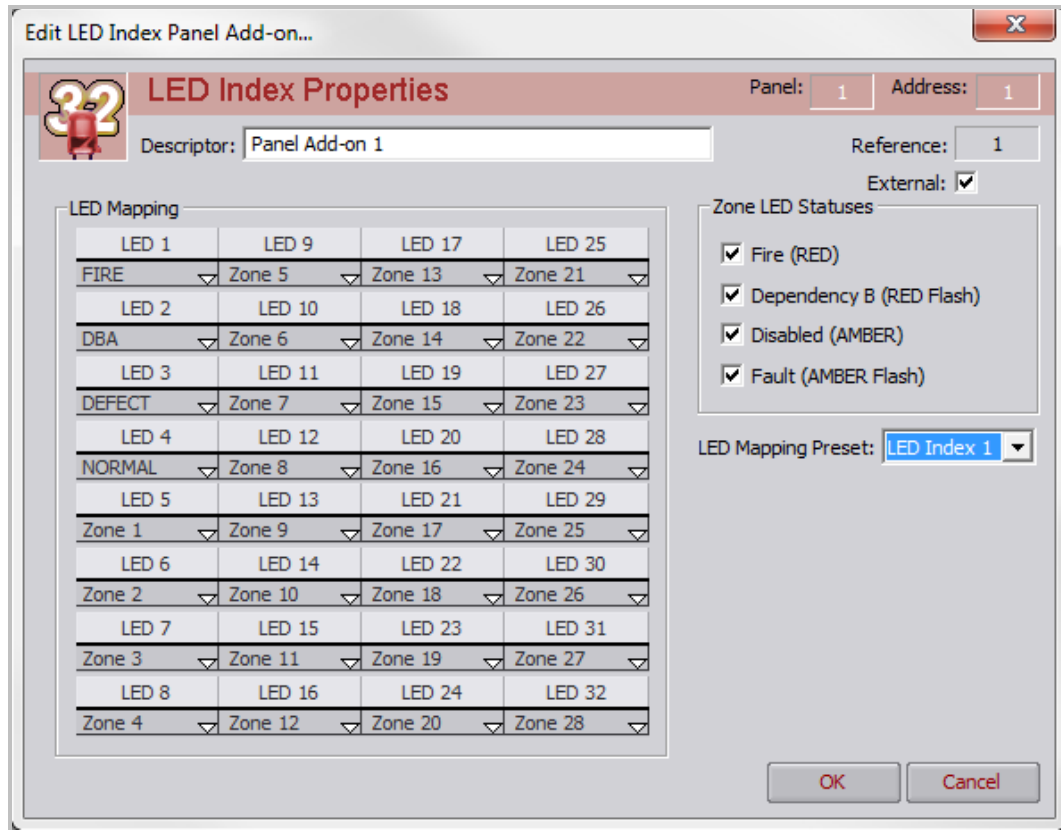
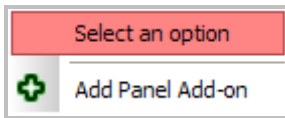

Figure 117: Editing 32 Zone Properties

The 32 Zone Indicator Card Add-On editing dialog box consists of two types of fields:

1. Non-editable (informational) fields:
 - *Panel*: The panel number this module belongs to,
 - *Address*: The hardware address of this particular module; addresses can be in the range of 1 to 15,
 - *Reference*: The reference number of this module,
2. Editable fields:
 - *Descriptor*: Allows the user to enter a 40 character descriptor describing this Add-On,
 - *External*: If this checkbox is checked then this Add-On is to be used on the external bus
 - *Zone LED Mapping*: This set of fields allows the user to provide mapping between zone numbers and LED's.
 - *Zone LED Statuses*: This set of fields allows the user to set FIRE, Dependency B, Disabled and Fault LEDE statuses
 - *LED Mapping Presets*: This allows a preset Zone LED Mapping to be applied to the LED Mapping fields.

Menu

Right-clicking on the 32 Zone Indicator Card Add-On parent item from the Tree View opens the menu, as shown below. It contains an option to add an Add-On to the panel.

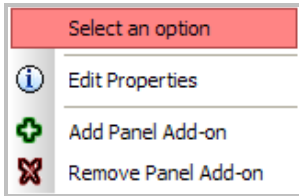

Right-clicking on an existing 32 Zone Indicator Card Add-On from the Tree View opens the menu, as shown below. It contains an option to add or remove the current Add-On, or via the 'Edit Properties' option to open the Add-On editing dialog box.

10 Remote Control

The application provides a Remote Control capability, allowing the user to interact with an attached panel via a graphical representation of the panel's LCD display and controls.

The various input 'devices' on the panel, such as the buttons and keyswitch, are faithfully emulated in the Remote Control graphical representation, such that clicking on one of the buttons in the Remote Control will appear as if actually pressing the corresponding button on the front panel.

The Menu

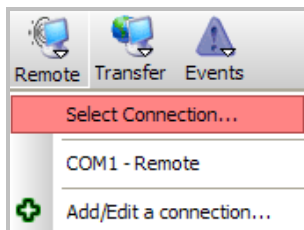

Clicking on the 'Remote' button in the main toolbar displays a connection menu, listing the connection that can be used to host a Remote Control session. Each connection is listed with its communications port and user-defined connection name. A Remote Control session begins once the user selects a connection from the Add/Edit menu.

Connecting

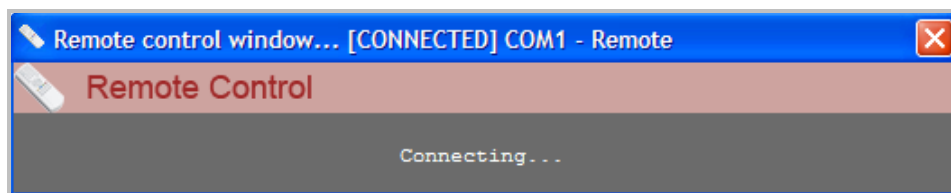

Selecting the appropriate connection from the menu the above dialog box appears, letting the user know that the application is attempting to connect to the panel to initiate Remote Control.

10.1 Operation

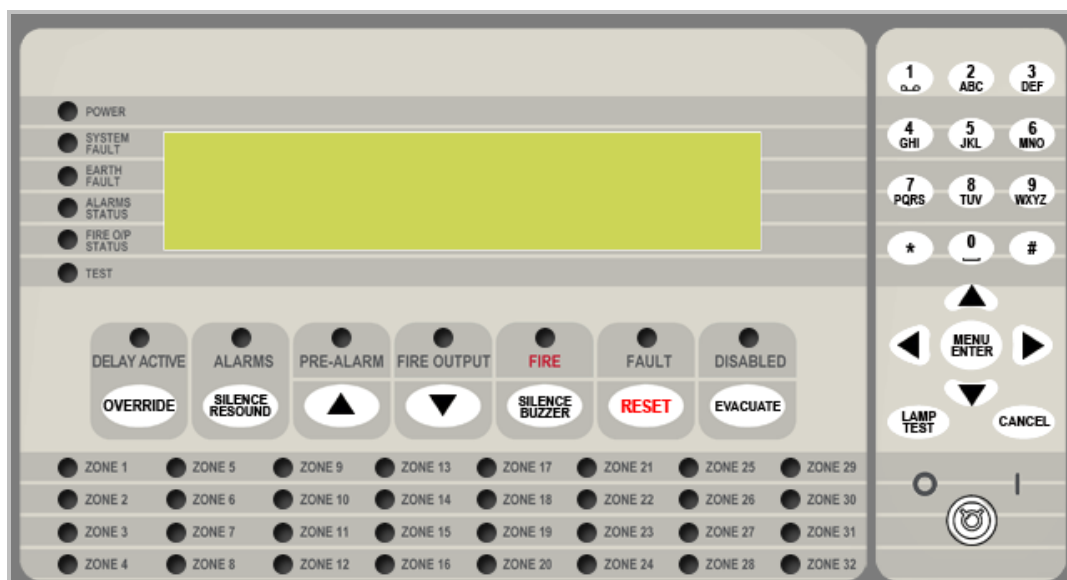

Figure 118 SmartTerminal

After a valid connection with a panel has been established *and* a remote control session has been initiated, the above control panel is opened.

The remote display control panel functions in the following manner;

- The representative LCD display in the graphical representation closely copies that of what is actually currently being displayed on the hardware front panel
- The graphical LED's will be illuminated / flash the same as those on the hardware front panel. Due to different timing considerations the LED flash rates may differ, as this is a function of the Remote Control session protocol and not a true reflection of the hardware front panel.
- Clicking on a graphical button has the same effect as if the user had pressed the corresponding button on the hardware front panel.
- The Remote Control session is a mutually exclusive one and will not hamper the operation of the hardware front panel nor hinder the correct operation of the connected panel in any way; i.e. a Remote Control session is transparent to the operation of the panel.

10.2 Transfer

The application provides a method to transfer both data and code to and from the attached panel via the use of a user-friendly 'transfer wizard'.

The panel is attached to the PC via a connection as defined above.

A method of transfer is useful, if not mandatory, for the following cases:

- Transferring configuration data to a panel
- Transferring configuration data from the panel to the application, for archival and/or editing
- Transferring new firmware, boot and/or application, to the panel

The Menu

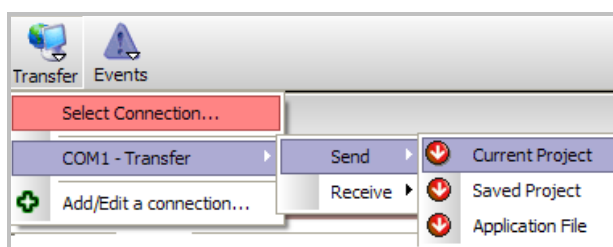

Figure 119: Transfer Menu

Clicking on the 'Transfer' button in the main toolbar displays a connection menu, listing all connections which can be used to host a Transfer session.

Each connection is listed with its communications port and user-defined connection name.

A Transfer session will begin once the user has selected a connection from the menu.

Operation

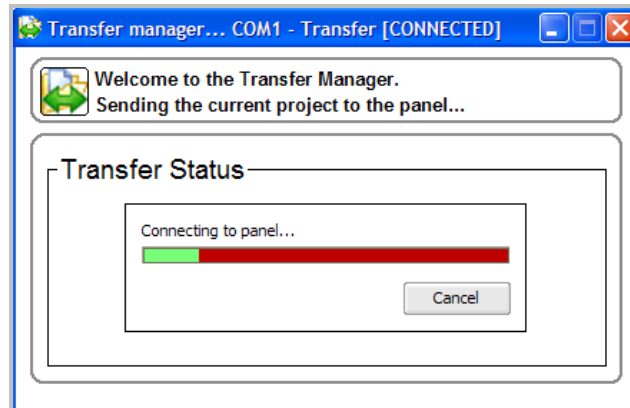

Figure 120: Transfer Connection Screen

Upon opening the Transfer Manager a window similar to that shown above is displayed. That is, the dialog box opens attempting to connect to a remote panel. If it is unable to open the port (either USB or serial) associated with the selected connection an error dialog box will be displayed instead; as shown below for the USB connection example.

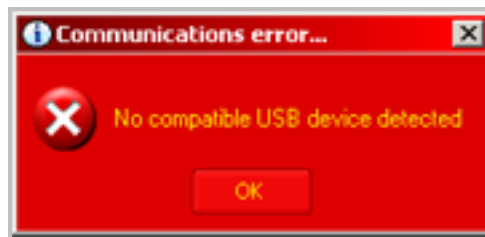

Figure 121: Error Screen

The Transfer Manager Dialog box consists of the following areas:

- The Top Frame: This just shows a short introduction to the 'Transfer Manager' and what we're actually attempting to do; e.g. send configuration, receive configuration, etc.
- The Bottom Frame: This frame contains the various information and procedural dialog boxes and prompts which appear as part of the respective transfer process, such as the 'Connecting to Panel' dialog as shown above.

In the event of a password error occurring (i.e. the specified password is not recognised at the remote panel) the dialog box shown below is displayed. This allows the user to specify a different password for this connection, which is also updated in the system registry, and becomes the new default password for the current connection.

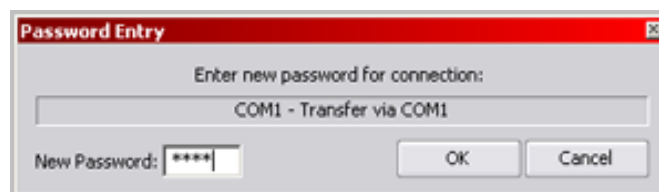

Figure 122: Password Entry

Sending Configurations with the Transfer Wizard

The user has two choices when sending a configuration via the transfer manager;

1. Current Project: The project/configuration currently being edited, or open in the LoopMaster application, is sent to the remote panel.
2. Saved Project: A previously created and saved project/configuration file will be sent to the remote panel. The user is responsible for selecting the file to be sent via the normal Windows file open and select procedure.

If an error occurs anywhere along the transfer process a dialog box will be displayed to the user, allowing the user to retry if they so wish. Selecting 'Cancel' will open another dialog box, whereby the transfer manager will attempt to restart the remote panel, as shown by the example below.

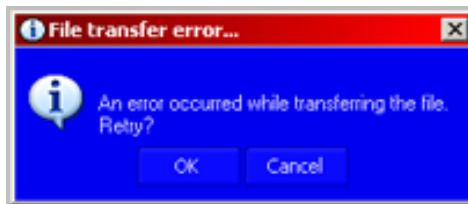

Figure 123: Error Screen File Transfer

If the remote panel cannot be restarted the following dialog box is displayed, otherwise the transfer manager dialog box will simply close with no error, signifying that the panel restart was a success.

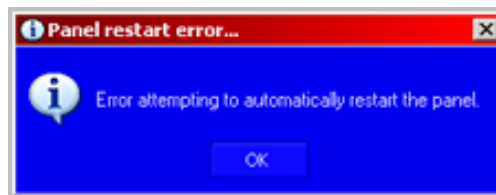

Figure 124: Error Screen Panel Restart

Upon successful connection to the panel the “negotiating” and “Sending File” screens are displayed, notifying the user as to the progress of the file transfer. Once the transfer has completed LoopMaster will automatically attempt to restart the panel as shown above.

If a file transfer is completed successfully the user will be notified by a dialog box as shown below.

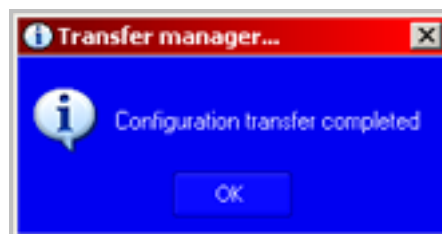

Figure 125: Completed Transfer Screen

Receiving Configurations with the Transfer Manager

The user has two choices when receiving a configuration via the transfer manager;

- Configuration To Current Project: The configuration held inside the remote panel is to be received and imported into the current configuration being edited, overwriting any data that may be present. The dialog box is shown below;

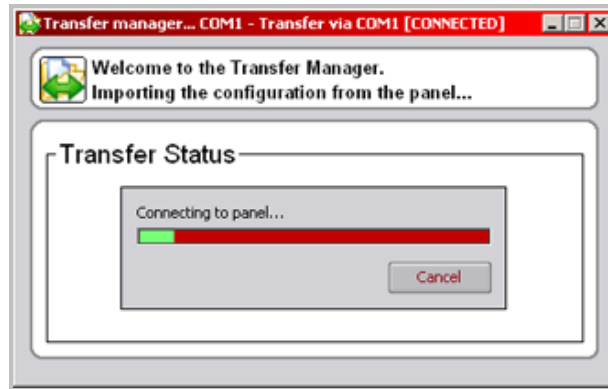

Figure 126: Receiving a Configuration to current project

- Configuration To File: The configuration held inside the remote panel is to be received and saved to a file of the user's choosing. The dialog box is shown below;

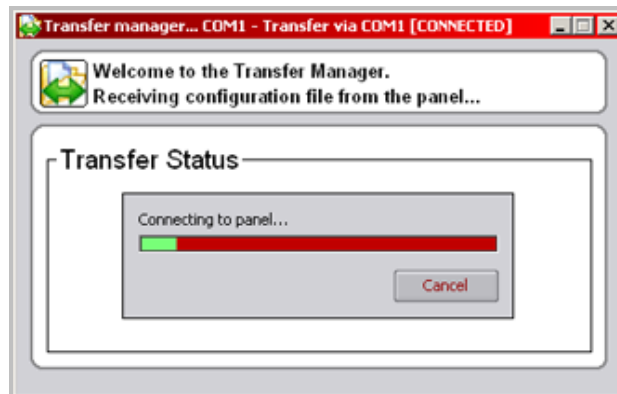

Figure 127: Receiving a Configuration to File

If an error occurs anywhere along the transfer process a dialog box will be displayed to the user, allowing the user to retry if they so wish. Selecting 'Cancel' will open another dialog box, whereby the transfer manager will attempt to restart the remote panel, as shown below.

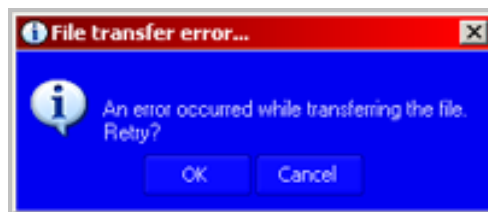

Figure 128: Error Screen

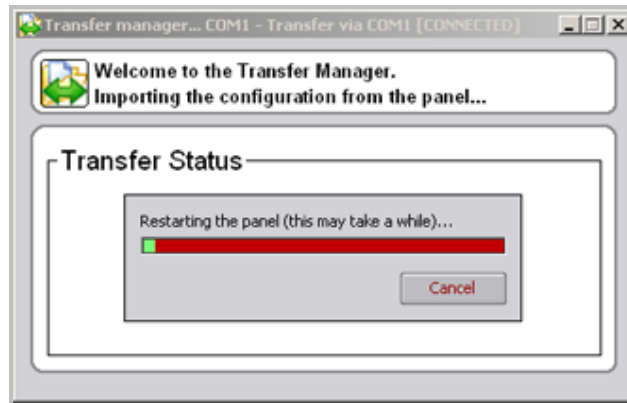

Figure 129: Restart Screen

If the remote panel cannot be restarted the following dialog box is displayed, otherwise the transfer manager dialog box will simply close with no error, signifying that the panel restart was a success.

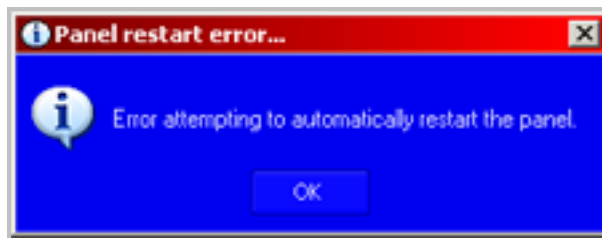

Figure 130: Error Screen

Upon successful connection to the panel the following dialog box is displayed, followed by another dialogue box, notifying the user as to the progress of the file transfer. Once the transfer has completed LoopMaster will automatically attempt to restart the panel.

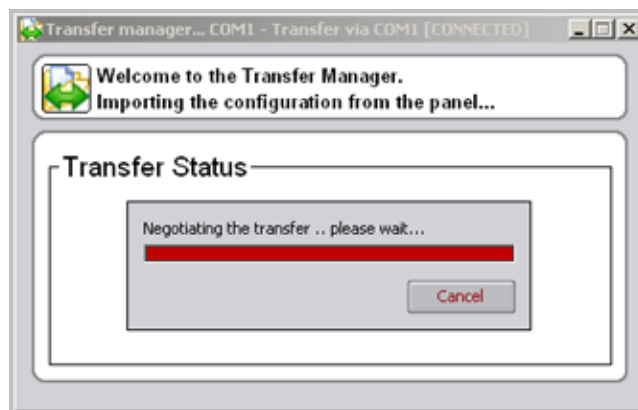

Figure 131: Transfer Screen

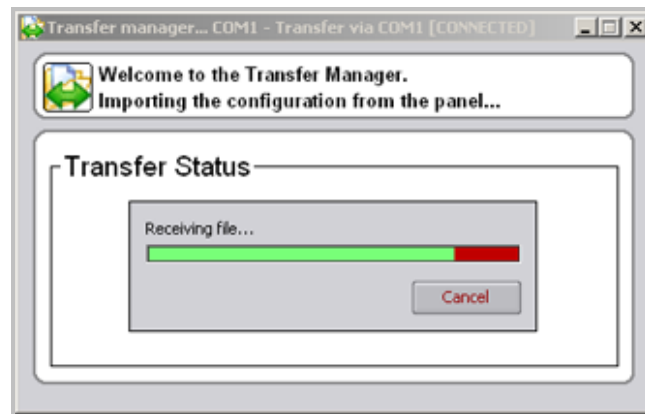

Figure 132: Receiving File Screen

If a file transfer is completed successfully the user will be notified by a dialog box as shown below.

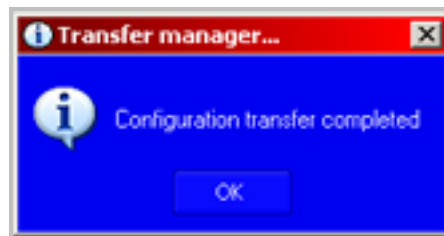

Figure 133: Completed Screen

Sending Applications with the Transfer Manager

On first entry, after the user has selected to send an application file to the panel, the user is presented with a file selection dialog box, where they are prompted to select an appropriate application file for sending to the remote panel.

The Transfer Manager, in this mode, can be used to send either firmware application files or firmware boot code files.

Clicking on an existing file or typing in a new filename will advance the user to the next step of the application sending process.

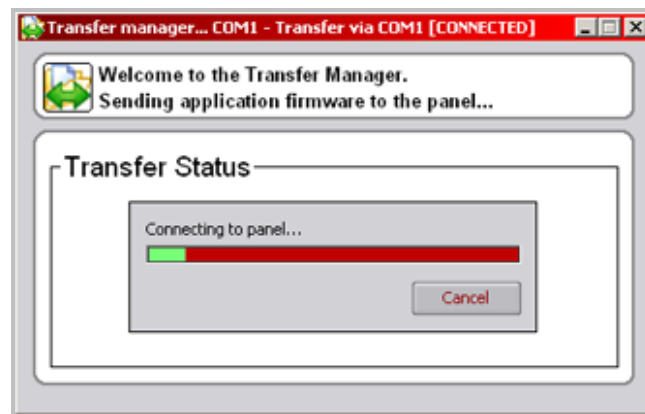

Figure 134: Sending Application

The above is the first dialog box displayed to the user and graphically shows the progress in attempting to connect to the remote panel. If successful in connecting to the panel the application sending process will advance to the next step, otherwise the user will be presented with an error message and given the option to repeat the process. In connecting to the remote panel, the panel is placed into boot mode and all loop processing is halted.

If the process is allowed to continue the user will be presented with the dialog box, below, which graphically shows the application sending progress. This is the phase at which the application file is being physically transmitted to the remote panel.

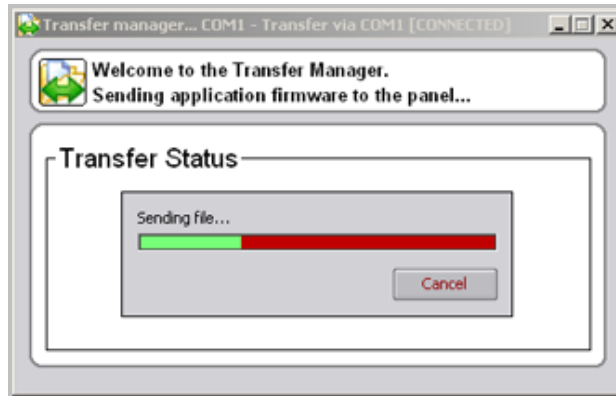

Figure 135: transfer Screen

Once a transfer has finished, the Transfer Manager will attempt to bring the panel back online, by telling it to go back to application mode. Once again, the user will be notified of the success or failure of this operation

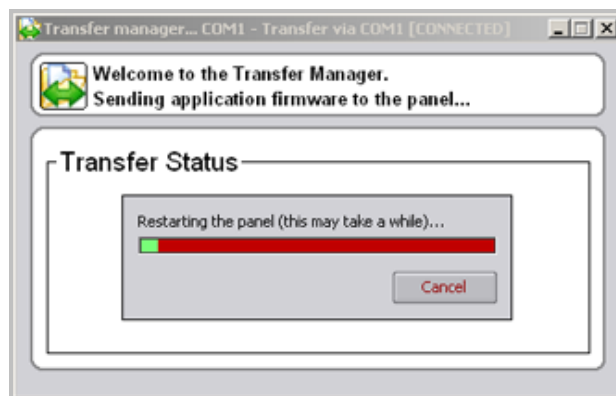

Figure 136: Restarting Panel Screen

Once the whole transfer process has been completed the user is presented with the screen shown below and asked to click 'OK'.

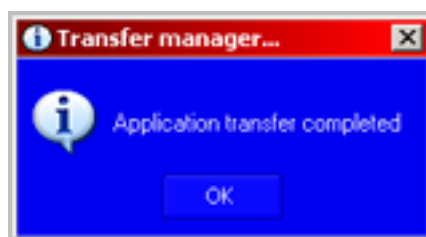

Figure 137: Error Screen

UNCONTROLLED DOCUMENT

NOTE: Due to AMPAC's commitment to continuous improvement specifications may change without notice.