



Fire detection and evacuation solutions that save lives.



ZoneSense PLUS Fire Alarm Control Panel EN54 2 & 4 1997

Installation, Commissioning & Operation Add On's

MAN 2512-5

Contents

1	About This Manual	3
1.1	Introduction	3
1.2	General Requirements	3
1.3	References	3
1.4	Symbols	3
1.5	PCB Removal / Replacement	4
2	Wiring to the Main Card BRD25MCB	5
2.1	Communications	5
3	Adding Control and Monitoring Facilities	6
3.1	Internal Communications Connector (RS485)	6
3.2	Programming	6
4	Installation and Wiring of Add-On Cards and Boards.....	7
4.1	Address Setting and Terminating the Communication Bus.....	7
4.2	Input Board BRD25SIPB	9
4.3	Relay Board BRD25EWRB	10
4.4	Fire Fan Module BRD25FCB.....	11
4.5	Fan Termination Board.....	12
4.6	General Indicator Card BRD25GIB-A	13
4.7	Switch and Indicator Card BRD25GIB-B.....	14
4.8	LED Annunciator Master (LAM) BRD25GIB-E	15
4.9	Sounder Board BRD25SOPB-A	18
5	Appendix A: Adding to the System Menu & Programming	19
6	Appendix B:Status and Programming Screens	21
6.1	Level 1 to 3 Status Screens	21
6.2	Level 3 System Programming	22
6.3	Level 3 Programming Menu.....	23

1 About This Manual

1.1 Introduction

This manual is an instructional tool for the installation and commissioning, of add on ancillary cards, modules and boards that can be fitted to the ZoneSense PLUS Fire Alarm Control Panel (FACP) and should be read in conjunction with the main Installation and Commissioning Manual.

1.2 General Requirements

The **ZoneSense PLUS** FACP has been designed and manufactured from high quality commercial components so as to comply with major world standards. To ensure these standards are not compromised in any way installation staff and operators should;

- Be qualified and trained for the task they undertake;
- Be familiar with the contents of this manual prior to the installation, commissioning or operation of a FireFinder control system;
- Observe anti-static pre-cautions at all times; and
- Be aware that if a problem is encountered or there is any doubt with respect to the operational parameters of the installation the supplier should be contacted.

1.3 References

ZoneSense PLUS Technical Manual

ZoneSense PLUS Operation & Programming Manual

ZoneSense PLUS Installation and Commissioning Manual





Apollo Detector / Device Manuals

Ampac Product Data Sheets

British Standard EN54 Parts 2 & 4

European Standard BS 5839

1.4 Symbols

- | | |
|--|-----------------------------------|
|  | Important operational information |
|  Note: | Configuration considerations |
|  | Observe antistatic precautions |
|  | Mains supply earth |
|  | DANGER mains supply present |

1.5 PCB Removal / Replacement

If the PCB's have to be removed the following precautions should be observed;

1. Removing the door will provide better access to the boards and ensure the hinges are not accidentally stressed.

2. Personal anti- static procedures must be followed. 
3. When disconnecting the telecom style connecting cable from the PCB, make sure that the cable remains connected to at least one board to prevent it being misplaced.

Note: Care should be taken when detaching this connector as it is necessary to depress the small locking tab to unlock the connector from its base. To reconnect the cable the connector must first be correctly aligned then pushed into the socket so it locks into position.

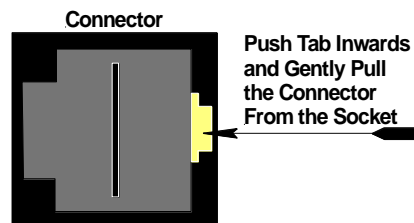

4. Carefully remove the retaining screws at each corner of the board taking care not to damage any of the components.
5. Place each board into anti- static storage once removed.

2 Wiring to the Main Card BRD25MCB

2.1 Communications

External Communications Terminals (RS485) TB2 1, 2 & 3

The RS 485 output drives the remote cards and mimics up to a distance of 1.2km from the panel itself. The external cabling (2x2 shielded pair plus power) is wired to TB2 +, - and earth.

 **Note:** If a fault occurs on the communications line the common FAULT and SYSTEM FAULT LED'S will be illuminated. The fault details can be displayed by selecting the Faults Menu.

Remote Cards

The number of cards that can be installed on the external communications bus are:

- x LED Annunciator Masters.
- 1 x 8 Way Remote Relay Output Board. This board provides 8 sets of normally open (NO), normally closed (NC) and Common (C) voltage free contacts rated at 1A @ 30V.

Main Card Comms Link K1

K1 MUST be inserted when only the front door panel cards and the Main Card are used as an FACP. If this is not the case and TB2 is cabled to LED mimics and / or 8 Way Remote Relay Boards a link is inserted in the last board to complete the communication circuit or if boards are mounted on the back pan and communications are wired from the Main Card then the last board in this chain MUST be terminated.

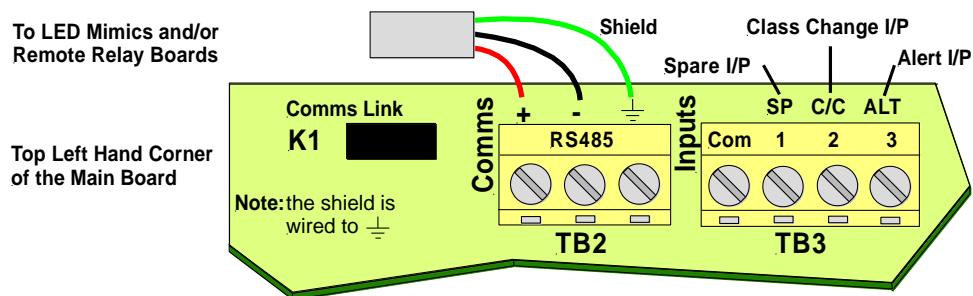

Figure 1: Wiring Detail

3 Adding Control and Monitoring Facilities

A combination of one of each type of board / card, but not all of them, can be mounted on the back pan or the front panel of the FACP to provide additional features to a standard panel. All board inputs or outputs are programmable to any combination of zones.

- Relay Board, BRD25EWRB –A or with a change of on board components it can also be installed remotely on the external communications bus as a Remote Relay Board BRD25EWRB -B
- Input Board BRD25SIPB -.
- Sounder Board BRD25SOPB.
- Brigade Interface Board BRD25BBA.
- Fire Fan Module consists of a Termination Board (BRD25FTB and front panel card BRD25FCB-.
- Agent Release Module consists of a Termination Board (BRD25ATB), front panel card (BRD25ARB–A) and if required a remote local control station (BRD25ARB–B).
- General Indicator Card. BRD25GIB -A
- Switch and Indicator Card BRD25GIBA
- LED Annunciator Master (LAM) BRD25GIB -E

 **Note:** To add or remove Cards from the FACP programming go to the SYSTEM Menu.

3.1 Internal Communications Connector (RS485)

PCB mounted connectors provide serial communications to internal ancillary boards. CN9 on the Main Card cables to CN1 or 2 on the front panel boards and CN5 on the Main Card cables to CN1 or 2 on the back pan boards

3.2 Programming

Refer to the Operation and Programming Manual to program the above options into the FACP.



Note: The Configuration label should be updated once the panel has been upgraded.

4 Installation and Wiring of Add-On Cards and Boards

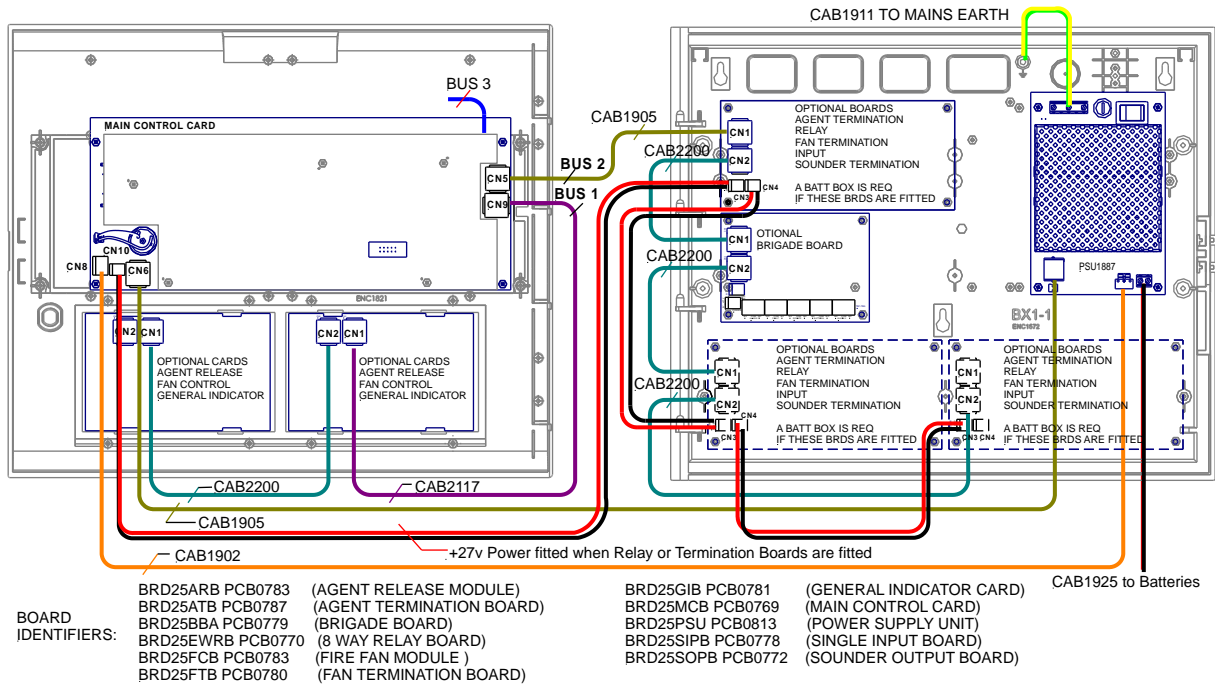

Figure 2: Typical Wiring, Ancillary Card and Board Positioning Within the ABS FACP

4.1 Address Setting and Terminating the Communication Bus

Address Setting (SW1)

Except for the LED Mimics in ZoneSense PLUS FACP's there can only be one (1) Board / Card of each type so the address on each board is set to 1.

Note: There can be up to 8 remote LED Mimics so the address of each is set from 1-8 depending on the number Mimics in the system. The information displayed at each location will be identical.

DIL Switch: ON = 1, OFF = 0

Address	1234	Address	1234
01	1000	05	1010
02	0100	06	0110
03	1100	07	1110
04	0010	08	0001

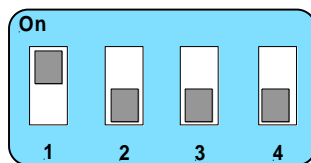

Figure 3: Address Table & Example of Switch set to Address 1

Terminating the Communication Bus

LK1 is the EOL Link and must be inserted on the last board on each communications bus. If not, a communications fault can occur.

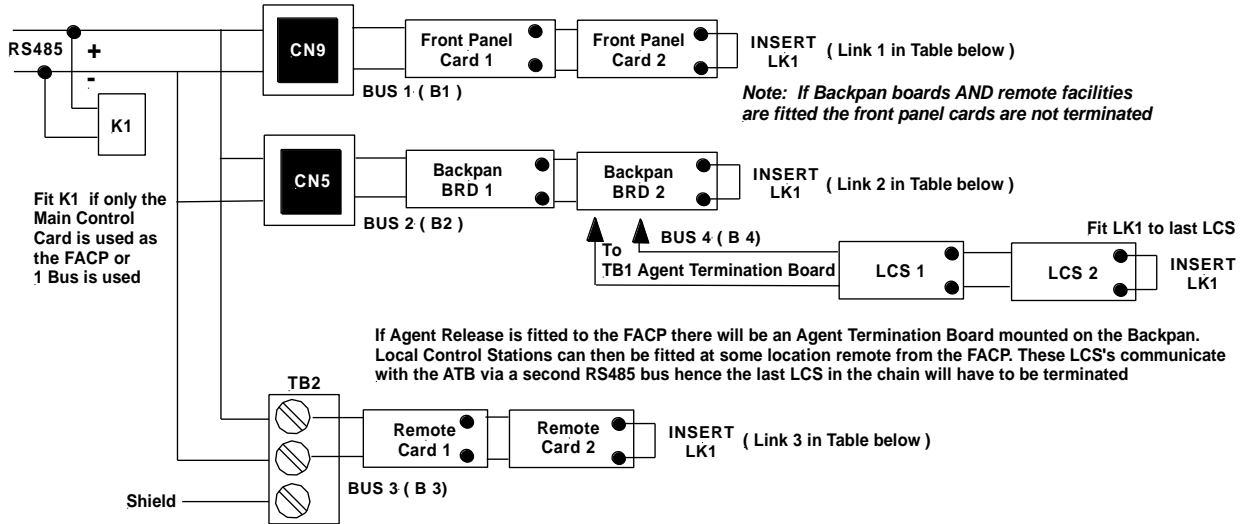

Figure 4: RS485 Communication Bus Terminating

Linking Table

Link	Bus Configuration						
	B1	B1,2	B1,3	B1,2,3	B,2	B2,3	B3
1	X & K1	X	X				
2		X		X	X & K1	X	
3			X	X		X	X & K1

X = Insert Link

B1: Bus 1 to Front Panel Cards

B2: Bus 2 to Backpan Boards

B3: Bus 3 to Remote facilities

B4: Bus 4 Local Control Station cabled to the backpan Agent Release Board.

Note: Programming and the communication process allows the Main Card to identify the type of board it is communicating with.

4.2 Input Board BRD25SIPB

Description

The Input Board makes provision for 16 voltage free contacts to be terminated to 16 optically coupled inputs. Its application is primarily for the monitoring of controlled ancillary equipment or to initiate an action / event due to a change of state from what is accepted as the norm.

Connectors

- CN1 Is designated as the input Comms .
- CN2 Is designated as the output Comms to the next board.
- CN3 27 Volts into the Board. Quiescent Current: 2.6mA
- CN4 27 Volts to the next Board unless it is the last board in the chain then it is left empty.

Terminal Blocks

TB 2 – 9 Taking note of the Common 0v terminals connect the voltage free contacts as shown below. Note: only the first 8 are functionally programmable in ZoneSense PLUS

SW1 There can only be 1 Input Board so the address on each board is set to 1.

LK1 Is the EOL Link and is inserted should the board be the last in the chain. If not inserted on the last board the Main Card will initiate a communications fault.

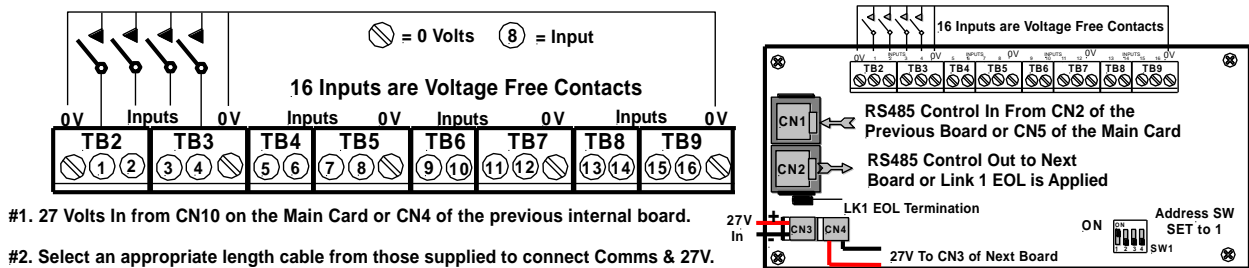

Figure 5: Typical Input Wiring and Board Layout

4.3 Relay Board BRD25EWRB

Relay Board (Internal) BRD25EWRB -A

The Relay Board has provision for 8 X 1 Amp voltage free change over contacts for control or monitoring purposes. Communication and control cabling is the same as all other internal boards.

Quiescent Current: 2.4mA

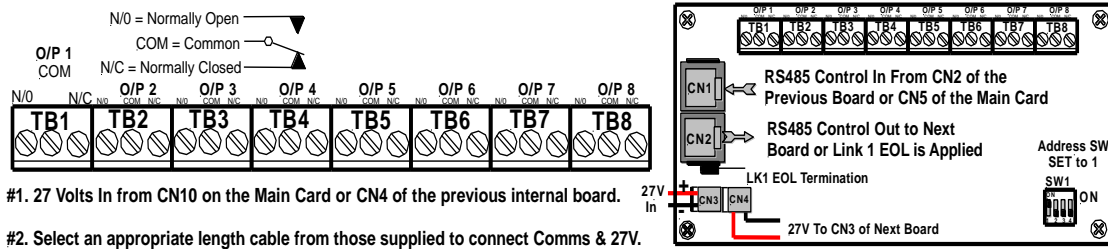

Figure 6: Board Layout

Relay Board (Remote) BRD25EWRB - B

In the remote version the Comms In and Out Terminal Block TB9 is cabled to the RS 485 Comms terminal block TB3 on the Main Card 302 – 7690 or LED Mimic and can be installed up to 1.2kms from the FACP.

Note: This version can be powered from the panel or an external 27 volt source due to the on board switched mode supply. Quiescent Current of both boards is 16mA

Note: In a system there can only be either a remote **OR** an internal board, not both.

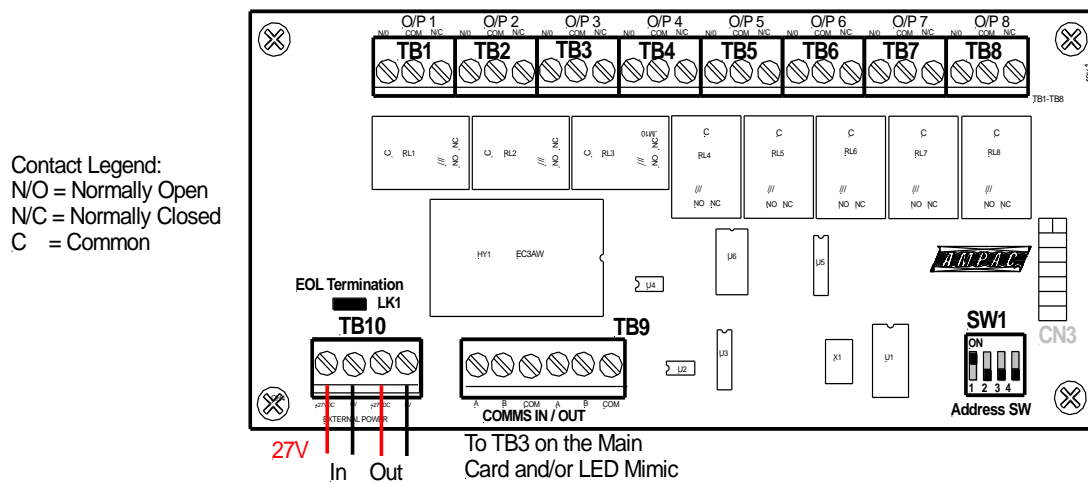

Figure 7: Remote Relay Board Layout

4.4 Fire Fan Module BRD25FCB

The Fire Fan Module has four (4) separate fan controls each having an On, Auto and Off function switch and a set of three (3) monitoring LED's. The LED's indicate the status of the equipment eg. Run, Fault or Stop. The two (2) arrow head keys are used to step up and / or down through the three (3) conditions. A slip in label can also be inserted into the hinged cover for identification purposes.

Quiescent Current: 13.5mA

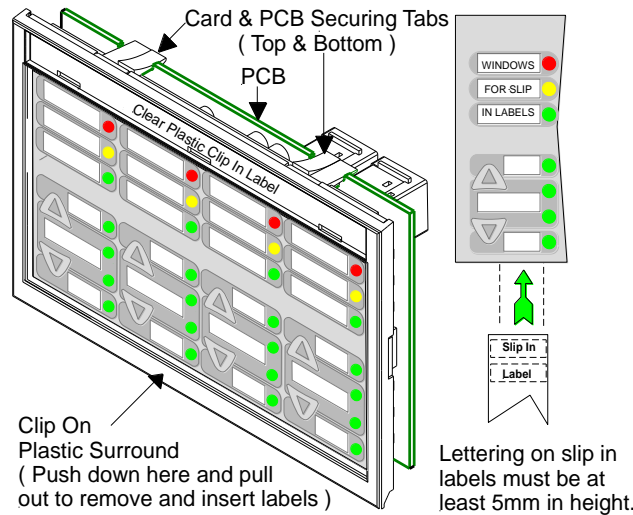

Figure 8: Fire Fan Module Front Panel

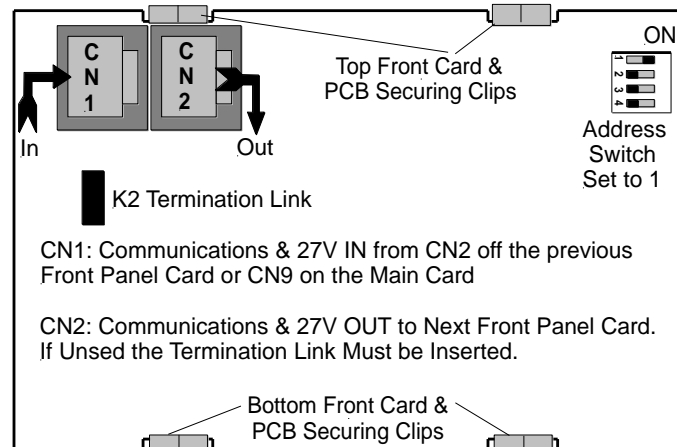

Figure 9: PCB Layout

4.5 Fan Termination Board

The Fan Termination Board interfaces between the Fire Fan Module and the plant/equipment it controls via the 24 volt 250mA Start, Stop, current limited, relay outputs and monitor inputs. Programmable monitoring of the field equipment is achieved using 0 volts as an input level to indicate run, fault and stop conditions of that equipment. Monitoring is programmed in the Function Menu for a 3, 4 or 5 Wire Start / Stop, Run, Fault, Stop & Common functions. The inputs are protected by way of resettable transorbs and resistive / capacitive networks.

Quiescent Current: 6.5mA

Connectors

- CN1 RS485 Control IN from previous board or Main Card
- CN2 RS485 Control OUT to next board or LK1 EOL termination is applied
- CN3 27 VDC IN from CN10 of the Main Card or CN4 of the previous board
- CN4 27 VDC OUT

Terminal Blocks

TB2 – 5 Are used to connect the fan control and monitoring wiring to the board.

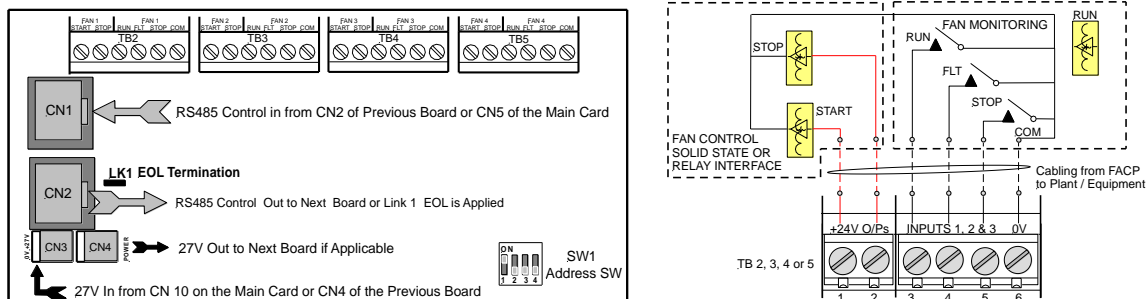

Figure 10: Fan Termination Board Layout and typical I/O wiring

4.6 General Indicator Card BRD25GIB-A

Note: The Cards BRD25GIB –A, B, C and D all have a common PCB. What sets them apart from each other is not only the function they perform but how the componentry is loaded onto the card to perform that function.

This Card indicates / displays the status of the inputs on the 16 Way Input Termination Board by way of Program selectable tri-coloured LED's with its function being identified on the front panel by slip in labels.

Quiescent Current: 3 to 3.5mA depending on the application

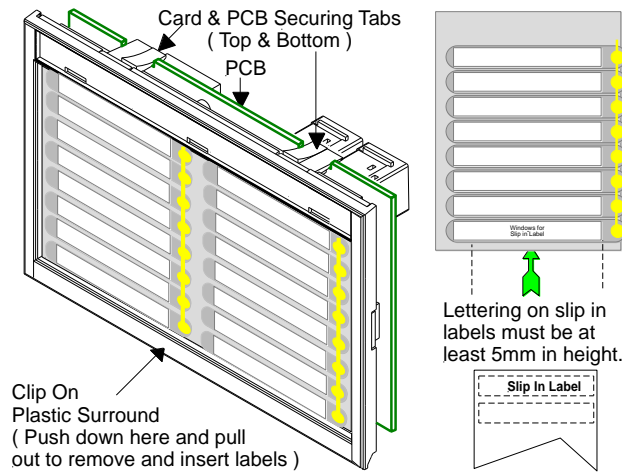

Figure 11: Front Panel Card Layout

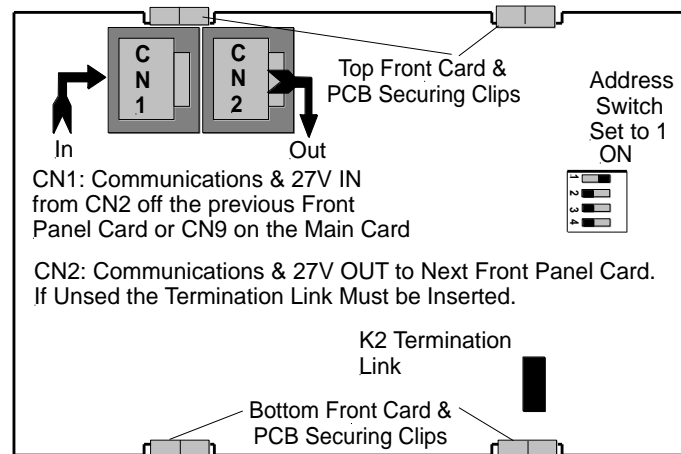

Figure 12: PCB Layout

4.7 Switch and Indicator Card BRD25GIB-B

This Card can effectively perform 2 different functions. Firstly the indicators monitor the first 8 inputs of the 16 Way Input Termination Board while secondly the switches can be programmed to manually operate a specific relay in the system.

Quiescent Current: 3.6mA

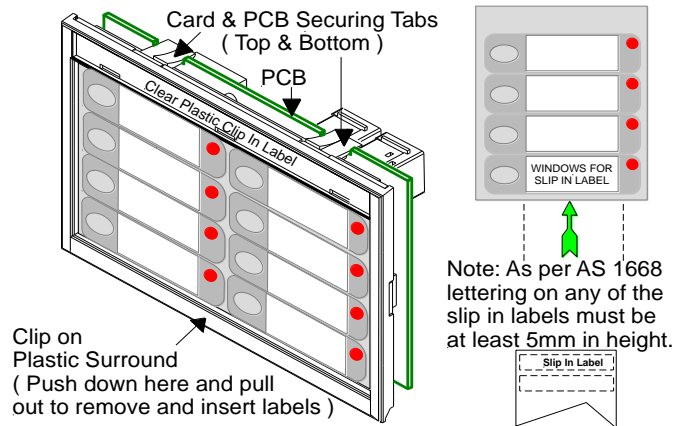

Figure 13: Front Panel Card Layout

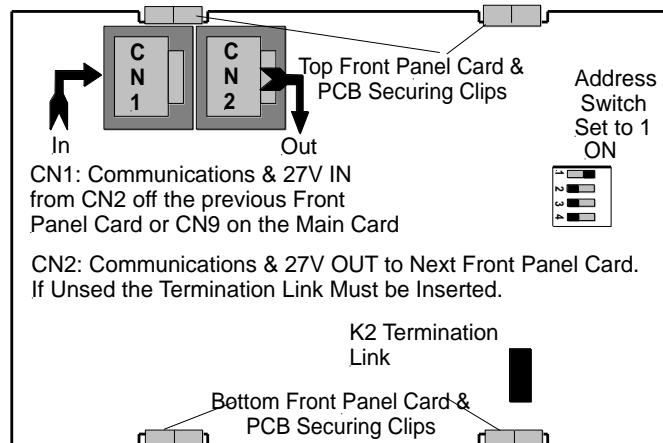

Figure 14: PCB Layout

4.8 LED Annunciator Master (LAM) BRD25GIB-E

The LAM provides remote stand alone FACP status, Alarm and Fault / Isolate Indication of 8 zones. Two push buttons, Lamp Test and Silence Buzzer, provide for local testing of the indicators and buzzer while the buzzer duplicates that at the FACP. A maximum of 4 LAMs with addresses of 1 to 4 may be cabled to an FACP.

Quiescent Current: 11mA

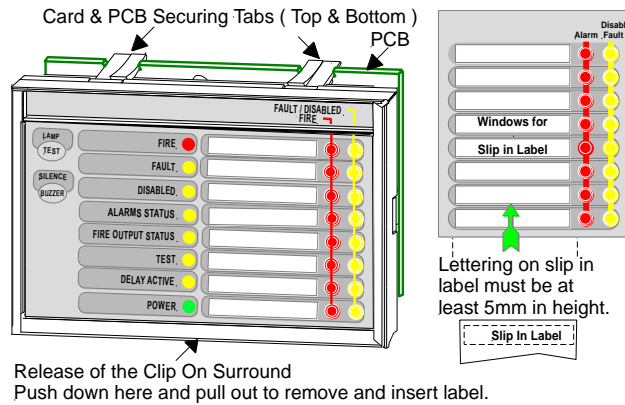

Figure 15: Front Panel Card Layout

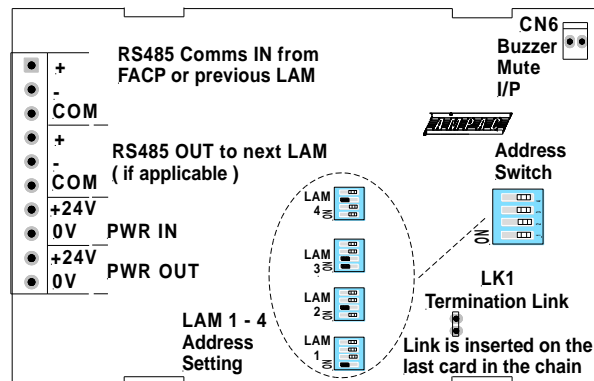
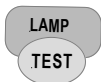

Figure 16: PCB Layout

Controls

Controls have tactile and audible feedback of operation.



Lamp Test - As well as sounding the buzzer confirms correct operation of the LAM by initiating a logically sequenced lamp test of all the indicators



Silence Buzzer - Silences the buzzer if activated by an alarm or fault condition that has been recognised and announced at the FACP. The LAM buzzer can also be silenced by the FACP silence buzzer function.

Indicators

There are twenty four active indicators on the front panel of the LAM.

Flashing indicators are used, the on / off periods are not less than 0.25 seconds and the flash frequencies are not less than:

1Hz for alarm indications (0.5 second on, 0.5 second off)

0.5Hz for fault indications (1 second on and 1 second off)

FIRE  **Red** The common Alarm indicator will be flashing when an alarm condition is present. The indicator will become steady when the acknowledge control is pressed

Any new alarm condition recognised at the FACP will cause the indicator to resume flashing.

FAULT  **Yellow** The fault indicator is illuminated steady by the presence of any fault. Refer to the FACP manual for details on fault conditions.

DISABLED  **Yellow** The disabled indicator is illuminated steady by the presence of any isolate condition on any zone, device or output.

ALARMS STATUS  **Yellow** Illuminated flashing at the fault rate by an open or short circuit condition on the FACP bell output.

Indicator will extinguish when the open or short condition has cleared.

FIRE OUTPUT STATUS  **Yellow** Illuminated flashing at the fault rate by an open or short circuit condition on the FACP warning system output.

Indicator will extinguish when the open or short circuit has cleared

TEST  **Yellow** Illuminated flashing at the fault rate by an open or short circuit condition on the FACP ACF output.

Indicator will extinguish when the open or short condition has cleared

When the ACF output is isolated, then the indicator will be illuminated steady.

Display priority: Isolate (steady) then fault (flash)

DELAY ACTIVE  **Yellow** Illuminated flashing at the fault rate by an open or short circuit condition on the FACP ASE output.

Indicator will extinguish when the open or short condition has cleared.

POWER  **Green** The indicator is illuminated steady when the FACP is supplied with power (mains or battery) and flashes at the fault rate when there is a fault with the power supply

equipment. A fault can be no mains, high charger voltage, no charger voltage, low battery voltage or missing (or damaged) battery.

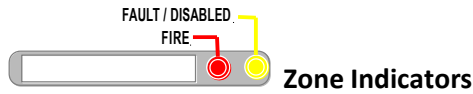

There are two indicators for each of the eight zones.

Zone Fire– Red (x8) Each indicator will show if the individual zone it represents is in the fire condition (flashing at the alarm rate and then steady when the acknowledge control has been operated at the FACP).

Zone Indicators Fault / Disabled – Yellow (x8) Each indicator will show if the individual zone it represents is in a fault condition (flashing at the fault rate, disablement of the zone will change the LED condition to steady). *Note: The isolate condition has priority.*

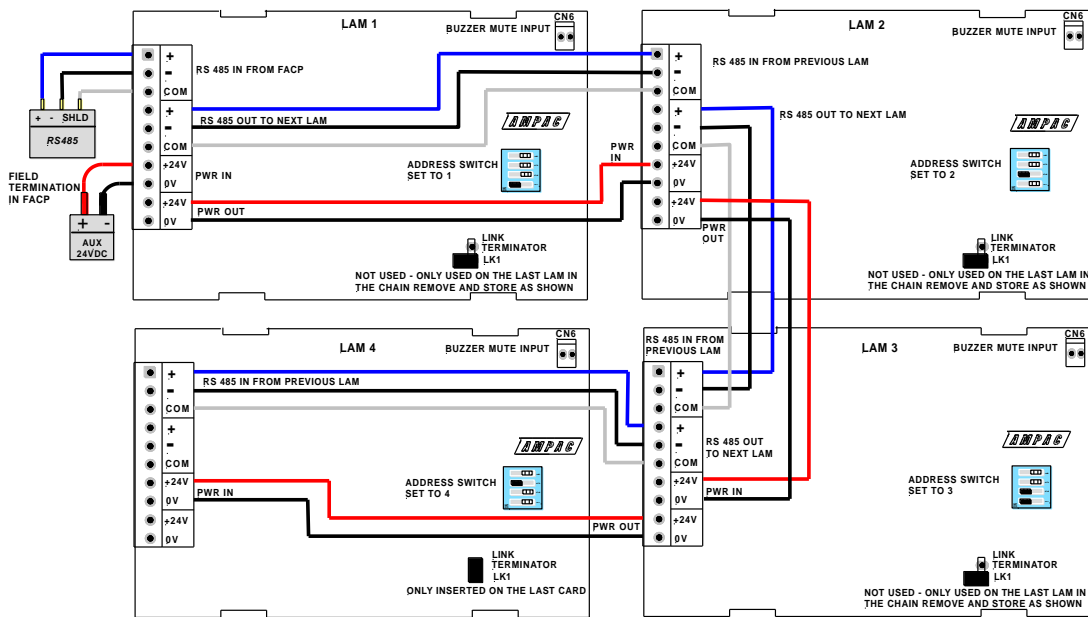

Figure 17: Cabling Multiple LAM's

4.9 Sounder Board BRD25SOPB-A

The Sounder Board expands the number of sounders that can be used on an FACP to 8. Each solid state output is rated at 24VDC / 500mA, and requires a 10KΩ End of Line (EOL) resistor regardless whether or not a sounder is wired to the circuit.

Quiescent Current: 5.6mA

Maximum Current per Output: 500mA

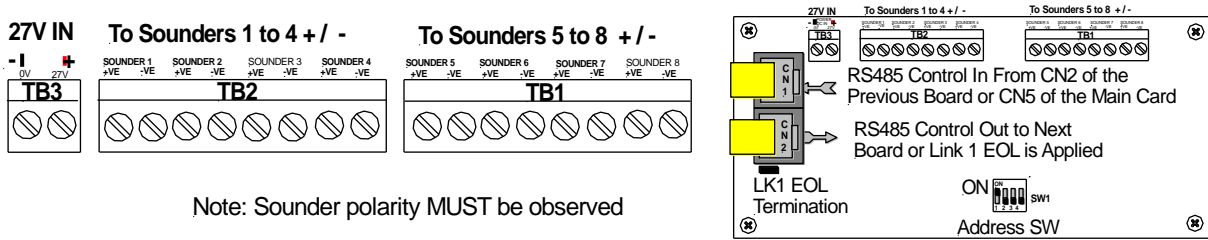

Figure 18: Wiring Detail & PCB Layout

Note: Sounder polarity MUST be observed.

5 Appendix A: Adding to the System Menu & Programming

In this example 1 Input Board, 1 Relay Board and 1 Sounder Board will be added to the system. The Display and Zone Labels will then be edited.

Step 1:

Go to the SYSTEM MENU and then follow the procedure as set out below.

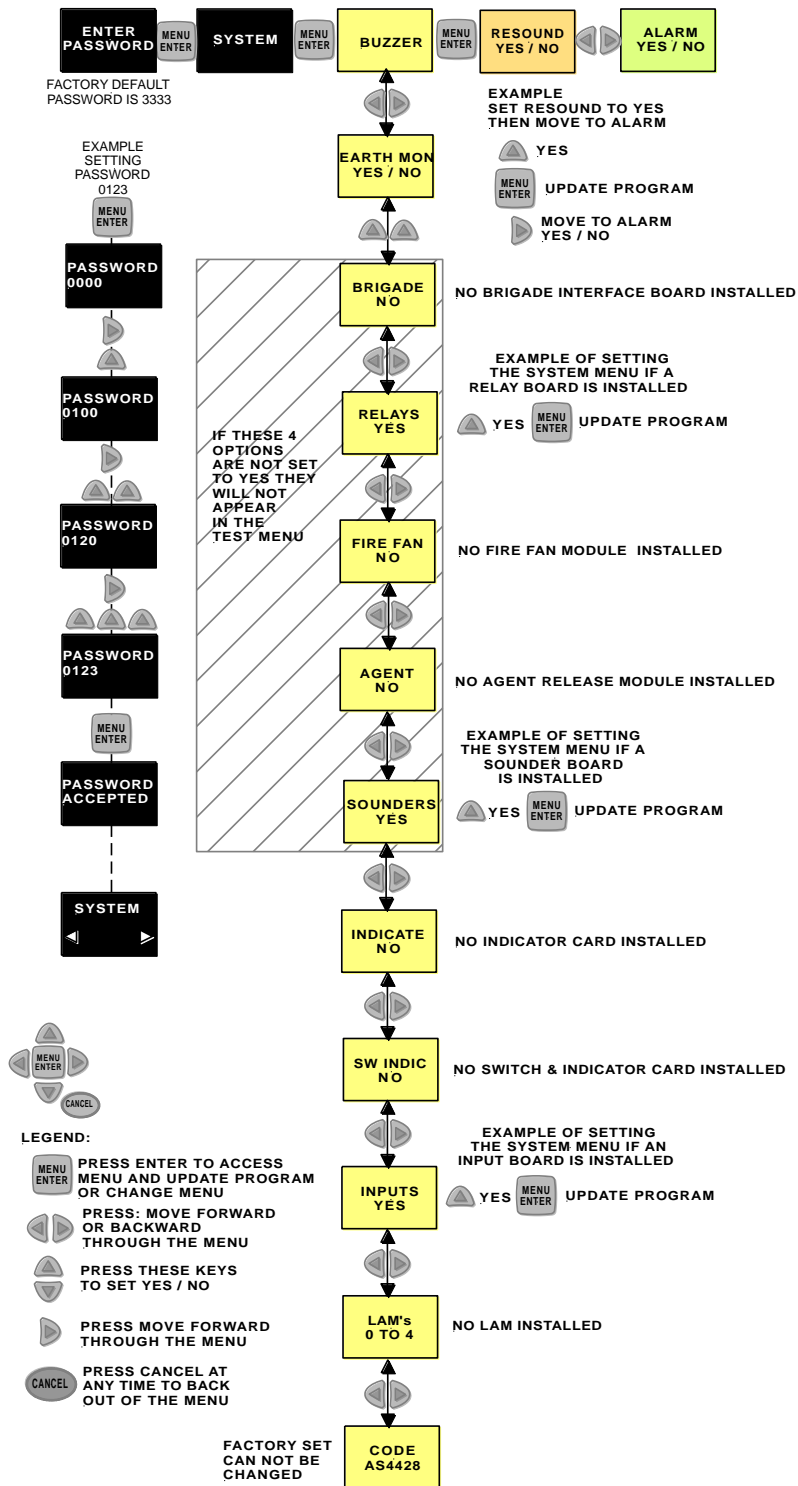

Figure 19: Example of Adding Input, Relay and Sounder Boards in the SYSTEM MENU

Step 2

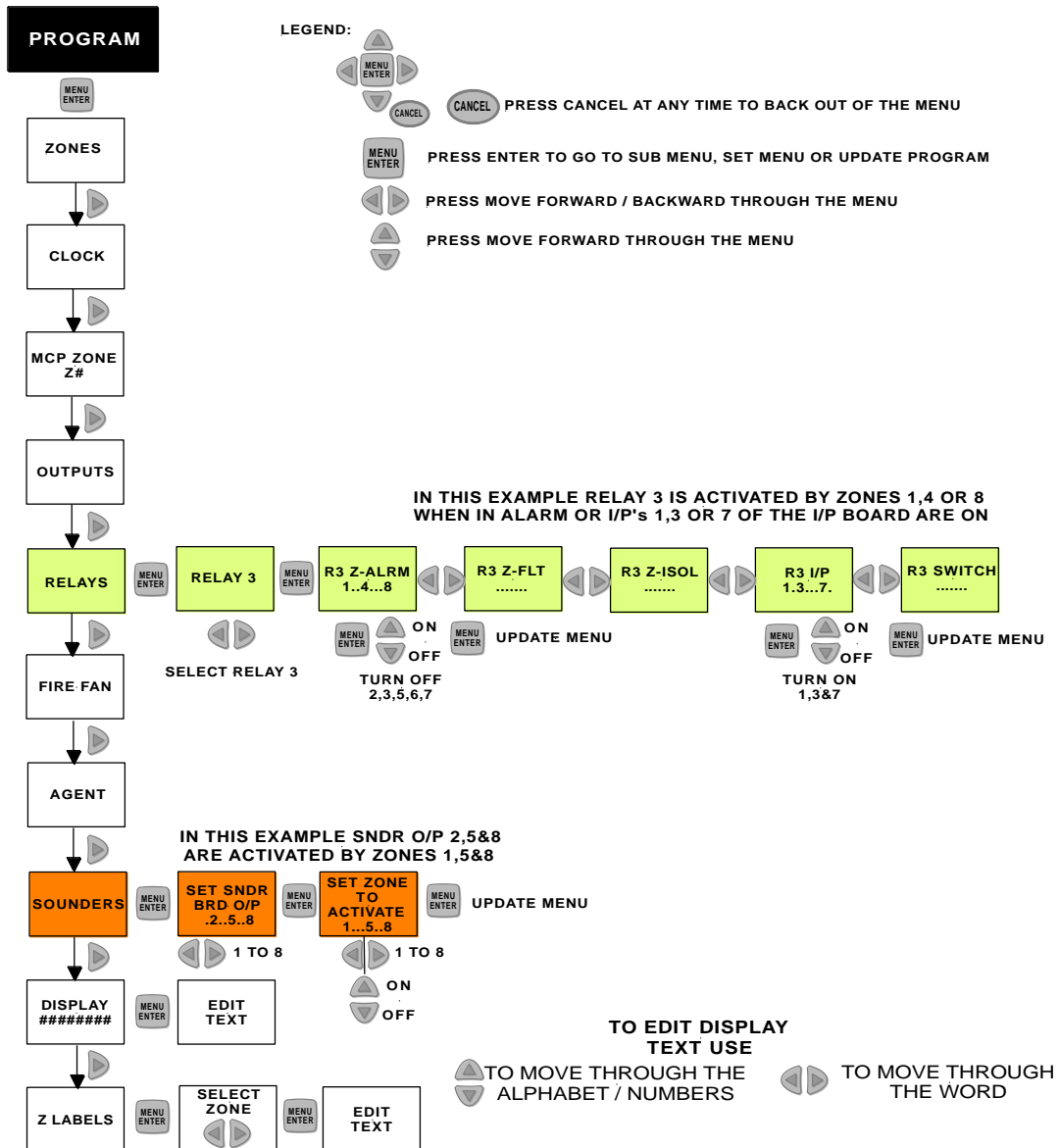

Figure 20: Programming the Relays and Sounders to be Activated by Zones and Editing Text

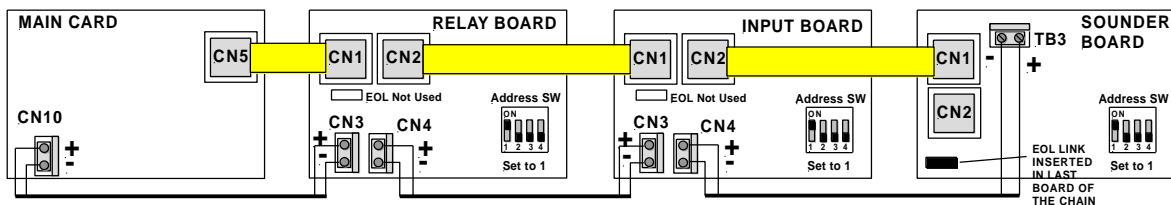

Figure 21: RS485 and 27V Cabling for the Installation of a Relay, Input and Sounder Board as in the SYSTEM and PROGRAMMING Menu Structures Above

6 Appendix B: Status and Programming Screens

The following shows all the screens that are possible in the FACP and how to navigate through them. If a screen is not available it means that option has not been installed or is not available to the model in use.

Operating Main Menu

LEVEL 1		LEVEL 2		LEVEL 3	
STATUS	FAULTS	TEST	DISABLE	SYSTEM	PROGRAMMING

6.1 Level 1 to 3 Status Screens

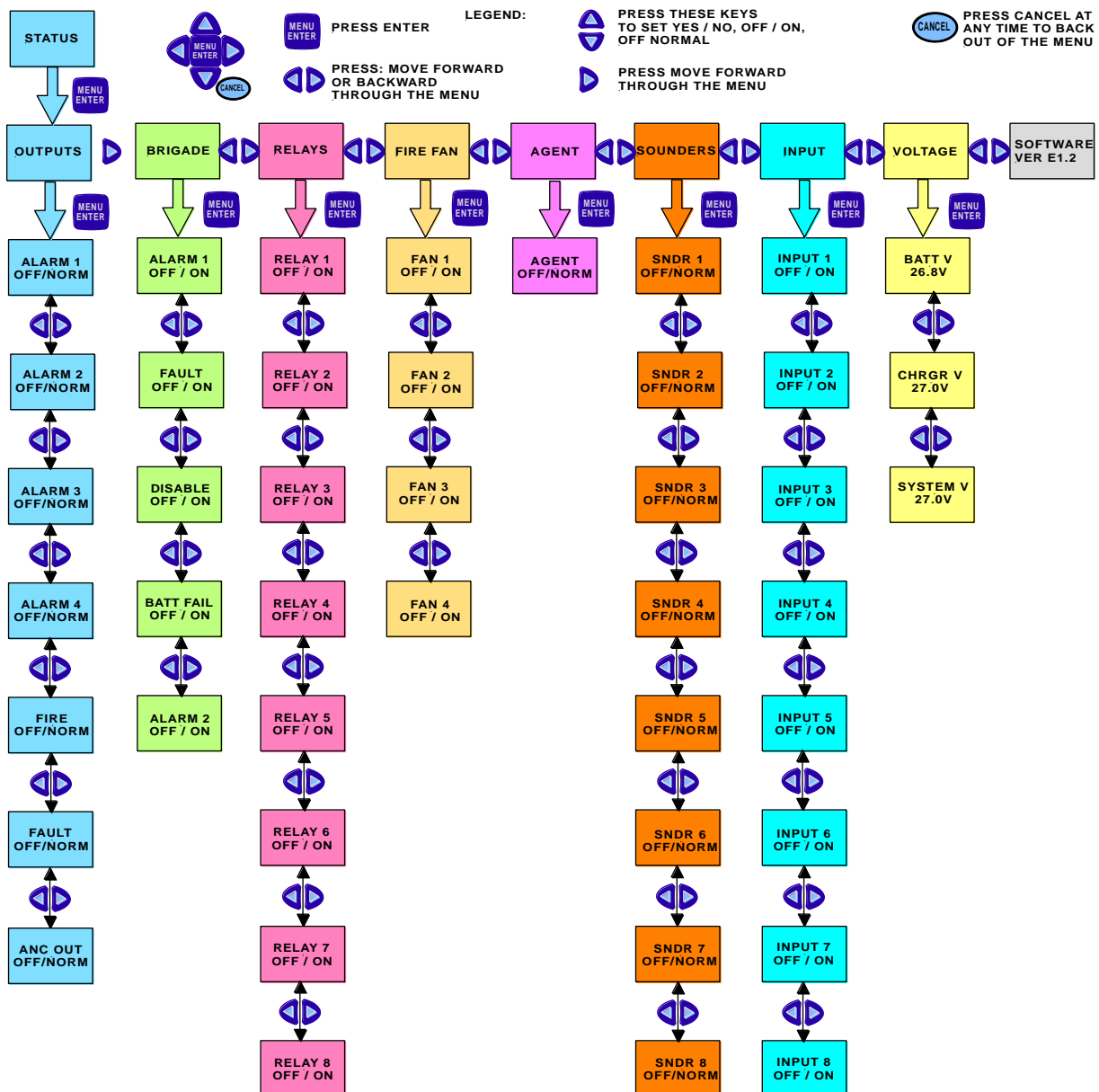

6.2 Level 3 System Programming

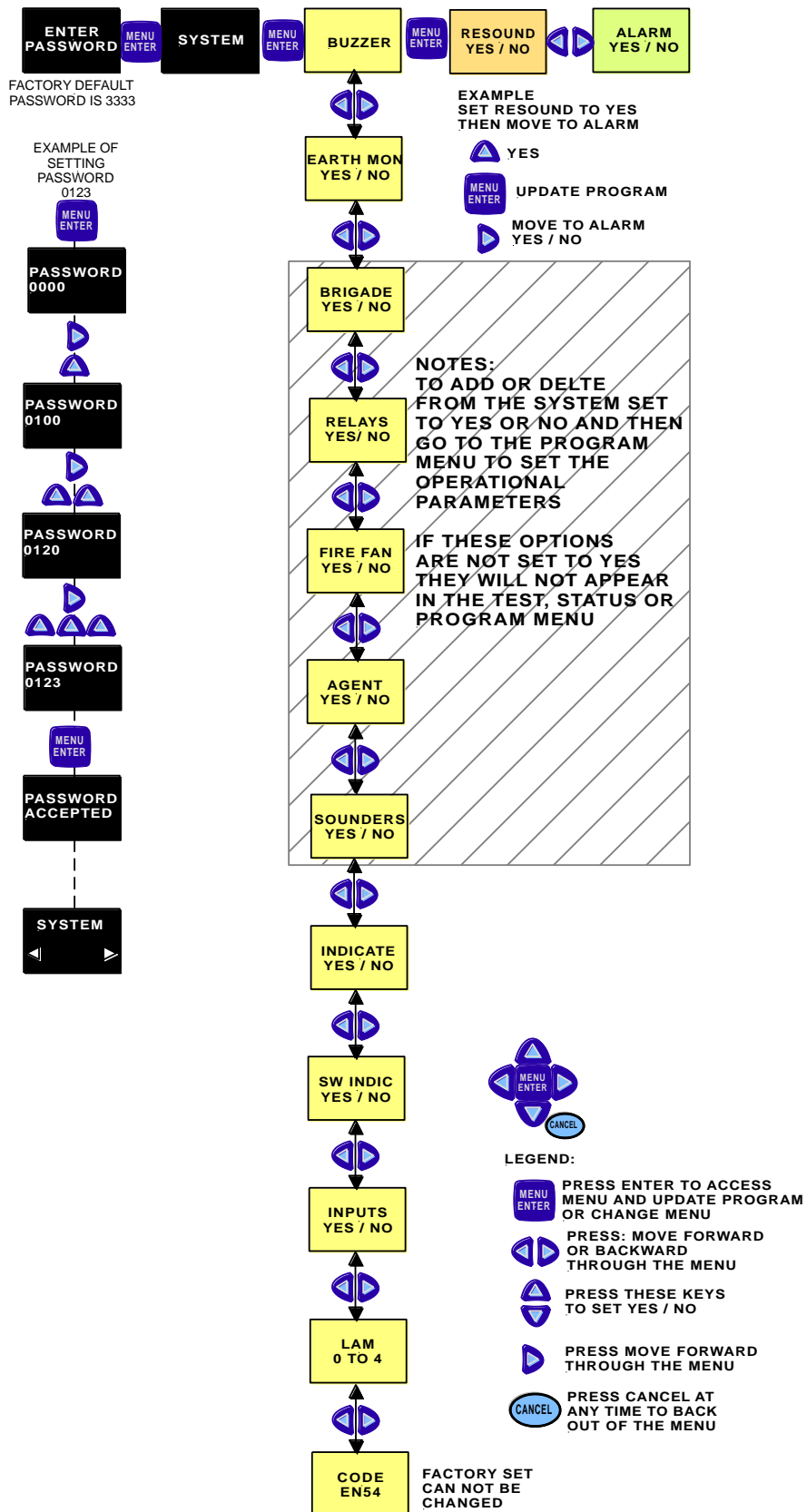

6.3 Level 3 Programming Menu

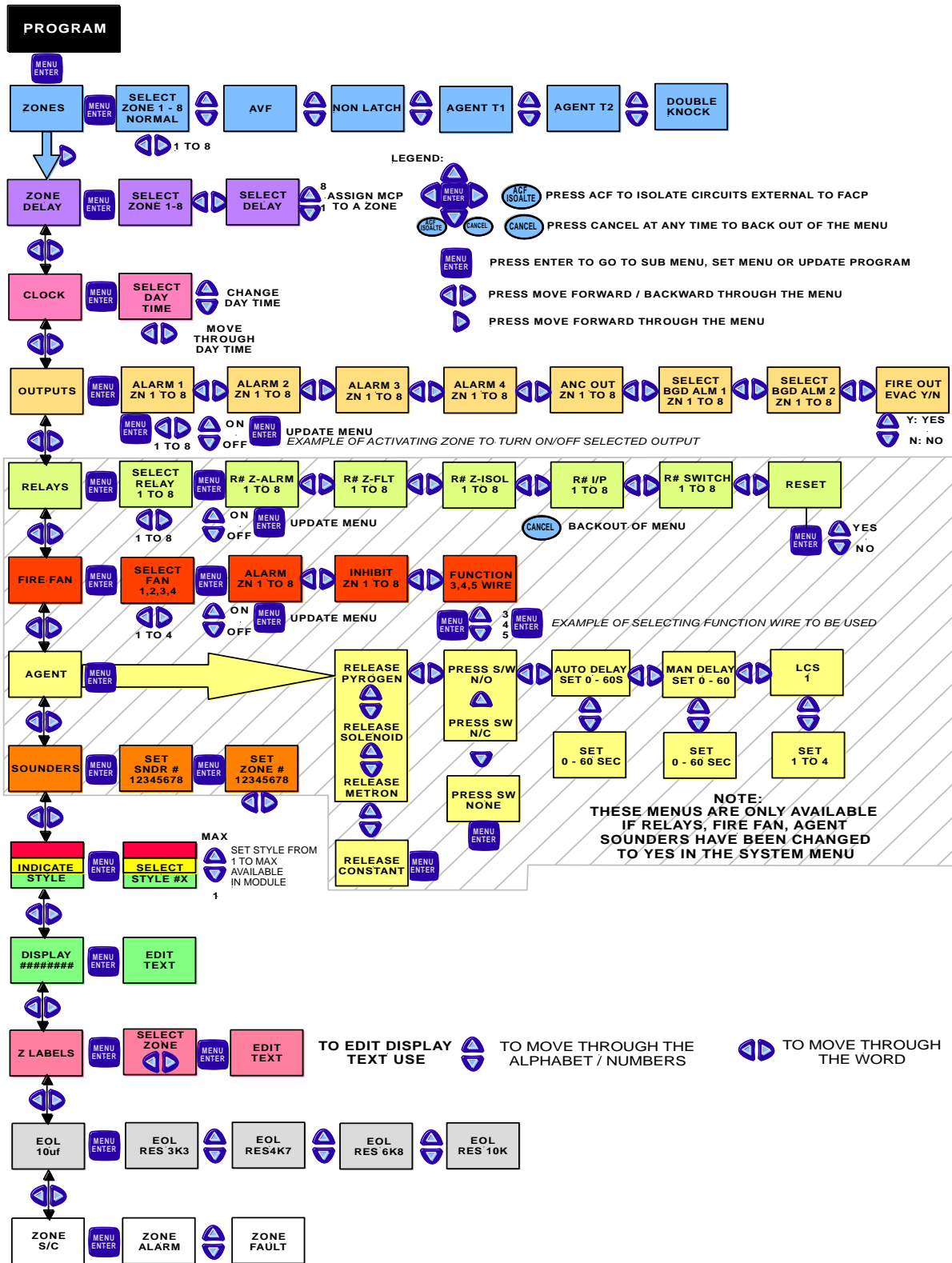

UNCONTROLLED DOCUMENT

NOTE: Due to AMPAC's commitment to continuous improvement specifications may change without notice.