



UV/IR² Flame Detector - High Ambient Temperature

The Ultra-Violet, dual Infra-Red (UV/IR²) Flame Detector is designed to protect areas where open fires may be expected and detects most flames from hydrocarbon fires with 4.3 m emissions through to invisible fires such as hydrogen.

The UV/IR Flame Detector is sensitive to flickering, low frequency (1-15Hz) infra-red radiation along with ultra-violet emitted by flames during combustion.

This detector has a UV sensor and two IR sensors which respond to different wavelengths of both the ultra-violet and the infra-red spectrum. The signals from these sensors are processed by the detector and checked for characteristics of a flame. The simultaneous detection of both the UV and the IR light by the sensors will signal an alarm. False alarms from flickering sunlight, arc welding and lightning are eliminated by a combination of UV and dual IR signal processing techniques.

The UV/IR² detector has selectable output options of relay contacts or 4 to 20mA signal as standard.

Features

- Highest immunity to false sources
- Solar blind
- Suitable for indoor and outdoor areas
- Unaffected by convection currents, draughts or wind
- Proven response to multiple fuel types
- Multi-spectrum detection
- Selectable output options
- Selectable response speed
- Selectable sensitivity levels
- Built in auto and manual test
- Low current consumption
- Fast response to fire



Applications

- Refineries
- Generators
- Compressor stations
- High voltage equipment
- Power plants
- Fuel loading racks
- Chemical plants
- Tunnels
- Nuclear power sites
- Storage tanks
- Engine rooms
- Pharmaceutical production
- Military applications
- Marine Industry
- Aircraft hangars
- Petrochemical offshore/onshore
- LNG/LPG production

Item Number

4108-2015 UV/IR² Flame Detector - High Ambient Temperature

Accessories

- 4108-3001 Stainless Steel Adjustable Mount
- 4108-3003 Stainless Steel Weather Shield
- 204-0032 Portable Flame Detector Tester



Mechanical Specification

Housing Material	Die Cast Zinc Alloy (ZA12)
Housing Colour	Blue
Dimensions	142(H) x 108(W) x 82(D) mm
Weight	2kg
Cable Gland Entries	2 x 20mm
Wiring	1.0 to 4.0mm ²

Electrical Specification

Supply Voltage	14 to 30Vdc
Quiescent Current	8mA, RL2 energised
	4mA, current loop, RL2 off
	3mA, RL2 off
Alarm Current	28mA, RL1 & RL2 energised
	20mA, current loop, RL1 & 2 off
	9mA, RL1 energised
Power Up Time	2 seconds max.
Test Signal Voltage	14 to 30Vdc
Relay Outputs	
	- Programmable
- Ratings: Current	1.0A Max.
Voltage	50Vdc Max.
Power	30W Max.
	(Note: Resistive Loads Only)

Environmental

Operating Temperature	-10°C to +85°C
Storage Temperature	-20°C to +65°C
Relative Humidity	95% Non condensing
IP Rating I	IP65

Performance

Range - Class I*	0.1m ² n-heptane at 25m
- Class 3	0.1m ² n-heptane at 12m (see EN54:10 for sensitivity settings)
Field of View	90° min. Cone
Spectral Response	
- UV	185 to 260nm
- IR	1.0 to 2.7µm

Response Characteristics – High Sensitivity

Fuel	Flame Size m (ft)	Distance m (ft)	Average Response time (seconds)
n-Heptane* (Yellow flame)	0.3 x 0.3 (1 x 1)	25 (82)	4
Methylated Spirit* (Clear flame)	0.5 x 0.5 (1.6 x 1.6)	25 (82)	6
Hydrogen (non-visible flame)	0.1 x 0.5 (0.3 x 1.6)	12 (39)	8

* has been tested and approved at Class I

Field of View

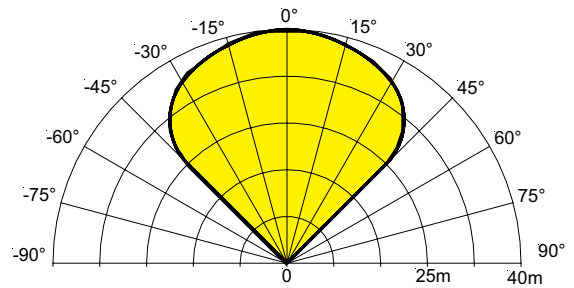

To meet the requirements of EN54:10 clause 5.4, where the ratio of the response points Dmax: Dmin should not exceed 1.41, the horizontal and vertical viewing angles max should not exceed ±30°.

Flame Detector

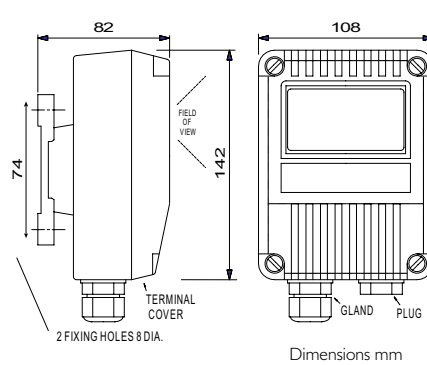

Mounting Bracket

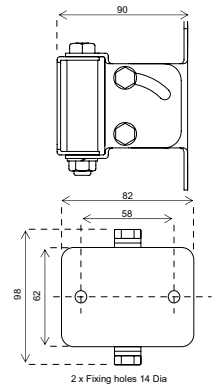

Installation Recommendations

Please refer to our User Manual for mounting and wiring instructions. The installation of Talentum® flame detectors should be undertaken in accordance with recognised national or international standards and codes of practice.