

Stainless Steel Flameproof (Exd) IR³ Flame Detector

The flameproof triple Infra-Red (IR³) Flame Detector is designed to protect specialist hazardous areas where open fires may be expected and detects almost all flames, including hydrocarbon fires with 4.3 m emissions through to invisible fires such as hydrogen.

The IR Flame Detector is sensitive to flickering, low frequency (1-15Hz) infra-red radiation emitted by flames during combustion even if the lens is contaminated by a layer of oil, dust, water, vapour or ice.

This detector has three IR sensors which respond to different IR wavelengths in order to discriminate between flames and spurious sources of radiation. False alarms from flickering sunlight are avoided by a combination of filters and signal processing techniques.

The IR detector has selectable output options of relay contacts or 4-20mA signal, as standard.

Features

- Excellent immunity to false sources
- Increased environmental protection
- Tolerant of fumes, vapours, dust and mist
- Suitable for indoor and outdoor areas
- Unaffected by convection currents, draughts or wind
- Proven response to multiple fuel types
- Multi-spectrum detection
- Selectable output options
- Selectable response speed
- Selectable sensitivity levels
- Built in auto and manual test
- Low current consumption
- Fast response to fire

Approvals:

ATEX & IECEx certified:
EXII 2GD Ex d IIC T4 Gb
Ex tb IIIC T1 35°C Db IP66 A21
[Zones 1, 21, 2 and 22]
SIL 2 rated.



Applications

- Chemical Plants
- Waste Recycling
- Nuclear Power Sites
- Engine Rooms
- Spray Booths
- Pharmaceutical Production
- Military Applications
- Marine Industry
- Printing
- Refineries
- Fuel loading racks
- Storage tanks
- Aircraft hangers
- Petrochemical onshore/offshore
- Biomass storage and handling
- LNG/LPG production
- Coal Handling

Item Number

4108-2013 Stainless Steel Flameproof (Exd) IR³ Flame Detector

Accessories

4108-3001 Adjustable Mount Stainless Steel
4108-3002 Weather Shield Stainless Steel
204-0032 Portable Flame Detector Tester



Mechanical Specification

Housing Material	316 Stainless Steel
Housing Colour	Natural
Dimensions	150(H) x 146(W) x 137(D) mm
Weight	6kg
Cable Gland Entries	3 x 20mm
Wiring	1.0 to 4.0mm ²

Electrical Specification

Supply Voltage	14 to 30Vdc
Quiescent Current	8mA, RL2 energised 4mA, current loop, RL2 off 3mA, RL2 off
Alarm Current	28mA, RL1 & RL2 energised 20mA, current loop, RL1 & 2 off 9mA, RL1 energised
Power Up Time	2 seconds max.
Test Signal Voltage	14 to 30Vdc
Relay Outputs:	
- Programmable	Normally Open or Normally Closed
- Ratings: Current	Latching or Non-latching
Voltage	1.0A Max.
Power	50Vdc Max. 30W Max. (Note: Resistive Loads Only)

Environmental

Operating Temperature	-10°C to +55°C
Storage Temperature Short Term Operation	-20°C to +65°C
Relative Humidity	95% Non condensing
IP Rating	IP66

Performance

Range	- Class 1* - Class 3	0.1m ² n-heptane at 25m 0.1m ² n-heptane at 12m (see EN54:10 for sensitivity settings)
Field of View		90° min. Cone
Operating Wavelength Band - IR		0.75 to 2.7µm

Approvals

SIL 2	C127_CT003_(2.0)
Baseefa ATEX	Baseefa08ATEX0270
Baseefa IECEx	IECEx BAS 08.0073

Response Characteristics – High Sensitivity

Fuel	Flame Size m (ft)	Distance m (ft)	Average Response time (seconds)
n-Heptane* (Yellow flame)	0.3 x 0.3 (1 x 1)	25 (82)	12
Methylated Spirit* (Clear flame)	0.5 x 0.5 (1.6 x 1.6)	25 (82)	25
Hydrogen (non-visible flame)	0.1 x 0.5 (0.3 x 1.6)	12 (39)	8

* has been tested and approved at Class I

Field of View

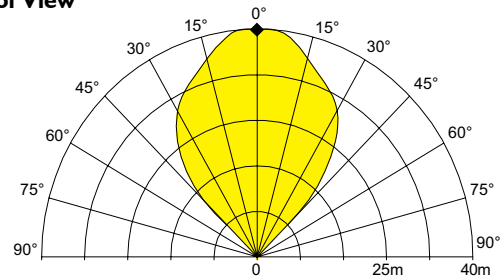

To meet the requirements of EN54:10 clause 5.4, where the ratio of the response points. $D_{max} : D_{min}$ should not exceed 1.41, the horizontal and vertical viewing angles max should not exceed $\pm 30^\circ$.

Flame Detector

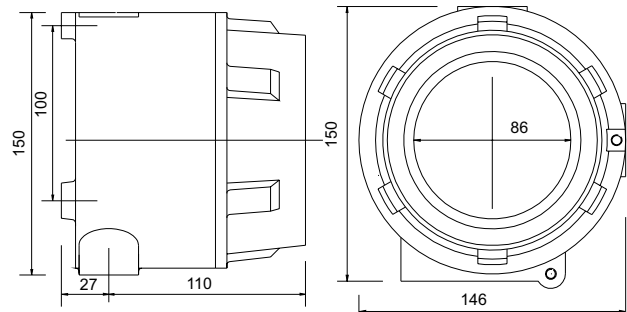

FIXING HOLES 2 X TAPPED M6 (8 DEEP)

Mounting Bracket

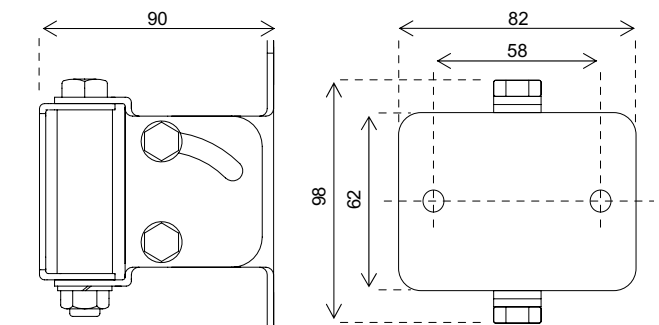

DIMENSIONS MM

2 X FIXING HOLES 14 DIA