

**Input Output Device Range**

**Item Number: 4210-0050, 4210-0057**

**Installation guide**

**Description**

The Input Output Device range comprises of the following eight variants:

4210-0050	Single Input Output Device DIN Mount
4210-0051	Single Input Output Device Enclosed
4210-0052	Single Input Device DIN Mount
4210-0053	Single Input Device Enclosed
4210-0054	Three Input Output Device DIN Mount
4210-0055	Three Input Output Device Enclosed
4210-0056	Three Input Device DIN Mount
4210-0057	Three Input Device Enclosed

The DIN-Rail Mounted Devices are designed to be mounted in an enclosure, clipped onto a standard 35mm DIN Rail (DIN46277) and secured using the built in fixing. End stops can also be used to provide additional security. Alternatively, the Devices can be mounted direct to an enclosure back panel using the internal preformed fixing holes.

The Enclosed variant Devices are each supplied within a backbox and are suitable for surface mounting.

Note: the Devices are not intended for outdoor use unless mounted in a suitable weatherproof enclosure.

The installation must conform to applicable local codes and be carried out such that the Devices are not subjected to exposure to temperatures exceeding the maximum ambient, exposure to moisture, dust and foreign bodies or exposure to a risk of mechanical damage.

The Devices are all loop powered and are controlled by the main fire control panel. The address is set using the onboard DIL switch.

Each Device incorporates a bi-directional short circuit isolator between the loop input and loop output terminals which will protect the external Input monitoring circuit against a single loop short circuit on either side of the device.

**Installation**

**DIN Rail**

Clip the Input/Output Device to the standard 35mm DIN rail using the Red locking clip located in the front of the device. Alternatively, fix direct to the enclosure back panel using appropriate M4 nuts and bolts.

**Enclosed**

Remove the clear ABS cover and securely mount the backbox to a wall or suitable structure using the integral fixing positions then install all external cables

using the knock outs and/or cable tray entry points as required.

1. Connect the cables from the detection loop and the conventional detector zone into the device. Ensure that the earth continuity is maintained.
2. Set the Device address using switches 1-7 on the DIL switch in accordance with the address Table 2 and record the location description of the device itself together with the address setting on the device fascia label.
3. For commissioning purposes, set the LED Indications to On using switch 8 of the DIL switch. This can be disabled upon completion of testing & commissioning.
4. Following commissioning ensure that the device is securely fastened and replace the ABS clear cover.

**Schematic Diagram (4210-0054)**

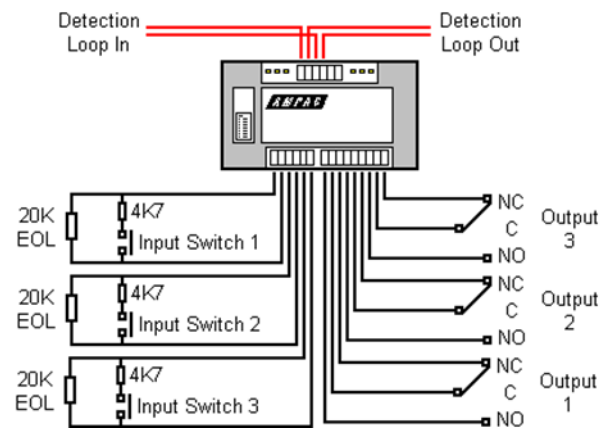

**LED Indications**

The Device has several onboard LEDs which provide indication for Input Active (Alarm), Output Active, Loop Polling/Short Circuit Isolation and Fault conditions.

Function	Colour	Mode	Description
Input	Yellow	On	Input is active
Input	Yellow	Flashing	Input is in fault
Output	Red	On	Output is active
S/C Poll	Green	Flashing	Device is being polled
S/C Poll	Green	On	Loop Short

**Input Output Device Range**

**Item Number: 4210-0050, 4210-0057**

**Installation guide**

**Maximum Loop Current Consumption**

4210-0050/1 (LEDs disabled)	
Quiescent Current	1.3mA
Input On	1.5mA
Output On	1.3mA
Total (All On)	1.58mA

Refer PDS for remaining range of devices.

**Commissioning**

It is important that the Device is tested thoroughly after installation by initiating an alarm condition at Input circuit. Initiation of both an open and short circuit fault condition at a suitable location on the circuit will also prove the integrity and reliability of the system.

**Troubleshooting**

Before investigating individual device faults, it is important to check that the system wiring is fault free. Earth faults on the data loops or zone input conventional detector circuits may cause communications errors to occur.

Many fault conditions are the result of simple wiring errors. Check all terminal connections to the device and make sure that the correct value EOL devices/resistors are fitted where necessary.

**Fault Finding**

Symptom	Possible Cause
No response	Incorrect address setting Incorrect loop wiring
Fault condition reported	Incorrect input wiring Incorrect EOL resistor fitted
Analogue value unstable	Dual address Loop data fault Data corruption
Constant alarm	Incorrect input wiring Incorrect EOL fitted Incorrect control panel software

**Installation guide**

**Table 2 – Address DIL Switch Settings**

The address is set using the first seven switches of the 8 way DIL switch (marked address). Switch 8 enables and disables the on-board LED indications.

DIL switch setting		DIL switch setting		DIL switch setting		DIL switch setting		DIL switch setting	
Address	1234567	Address	1234567	Address	1234567	Address	1234567	Address	1234567
1	1000000	26	0101100	51	1100110	76	0011001	101	1010011
2	0100000	27	1101100	52	0010110	77	1011001	102	0110011
3	1100000	28	0011100	53	1010110	78	0111001	103	1110011
4	0010000	29	1011100	54	0110110	79	1111001	104	0001011
5	1010000	30	0111100	55	1110110	80	0000101	105	1001011
6	0110000	31	1111100	56	0001110	81	1000101	106	0101011
7	1110000	32	0000010	57	1001110	82	0100101	107	1101011
8	0001000	33	1000010	58	0101110	83	1100101	108	0011011
9	1001000	34	0100010	59	1101110	84	0010101	109	1011011
10	0101000	35	1100010	60	0011110	85	1010101	110	0111011
11	1101000	36	0010010	61	1011110	86	0110101	111	1111011
12	0011000	37	1010010	62	0111110	87	1110101	112	0000111
13	1011000	38	0110010	63	1111110	88	0001101	113	1000111
14	0111000	39	1110010	64	0000001	89	1001101	114	0100111
15	1111000	40	0001010	65	1000001	90	0101101	115	1100111
16	0000100	41	1001010	66	0100001	91	1101101	116	0010111
17	1000100	42	0101010	67	1100001	92	0011101	117	1010111
18	0100100	43	1101010	68	0010001	93	1011101	118	0110111
19	1100100	44	0011010	69	1010001	94	0111101	119	1110111
20	0010100	45	1011010	70	0110001	95	1111101	120	0001111
21	1010100	46	0111010	71	1110001	96	0000011	121	1001111
22	0110100	47	1111010	72	0001001	97	1000011	122	0101111
23	1110100	48	0000110	73	1001001	98	0100011	123	1101111
24	0001100	49	1000110	74	0101001	99	1100011	124	0011111
25	1001100	50	0100110	75	1101001	100	0010011	125	1011111
								126	0111111